

Development of a Wearable for Remote Health Monitoring in Infants

Oluwadamilola Oshin, Sebastian Okhanigbe, Oluyinka Oni and Francis Idachaba, *Members, IAENG*

Abstract—The extremely undesired occurrence of sudden infant death syndrome (SIDS) begins with an infant who is put without constant check, although most of the infants are apparently healthy. The need to circumvent such occurrences demands at least keeping a constant check on the child's vital physiological changes by all means, most importantly remotely. When a child is going through distress the most likely change observed instantly is their heart rate and temperature. The device designed and built in this work would help keep check on the body temperature as well as heart rate. This health monitoring device would get signals from the wearable worn by the child whenever there is a change in temperature and heart rate, and send the vital parameters to the guardians wirelessly. With this kind of device in place, presented simply in form of a wearable, the growing rate of infant mortality due to lack of care givers and close attention or any form of negligence would be curbed.

Index Terms— Infant health, Remote monitoring, SIDS, Wireless Sensor, Wireless transmission

I. INTRODUCTION

THE evolution of healthcare and its practices aimed at providing continuous and remote monitoring of patient vital signs is characterized by major changes over the last decade. In particular, the increased growth in sensor technologies, communication technologies and data analysis, constitute the basis on which this new generation of health care systems are emerging [1]. Systems designed to be minimally invasive for health status monitoring, based on flexible and smart technologies conformable to the human body, will help to improve the autonomy and the quality of life of patients.

Health monitoring systems used by hospitals are mainly connected via cables. Their sizes and the power consumed are most times too large. They are often required to be used right next to the patients thereby reducing their mobility and

Manuscript received July 23, 2017; revised August 3, 2017.

This work was supported in part by Covenant University Center for Research, Innovation and Discovery (CUCRID), Covenant University, Ogun State, Nigeria.

Oluwadamilola Oshin is with the Dept. of Electrical and Information Engineering, Covenant University, Ogun State, Nigeria (phone: +2347087907028; e-mail: damilola.adu@covenantuniversity.edu.ng).

Sebastian Okhanigbe is with the Department of Electrical and Information Engineering, Covenant University, Ogun State, Nigeria (e-mail: Sebastian.okhanigbe@stu.cu.edu.ng).

Oluyinka Oni is with the Department of Electrical and Information Engineering, Covenant University, Ogun State, Nigeria (e-mail: oluyinka.oni@covenantuniversity.edu.ng).

Francis Idachaba is with the Department of Electrical and Information Engineering, Covenant University, Ogun State, Nigeria (e-mail: francis.idachaba@covenantuniversity.edu.ng).

ease and increasing their burden and risk. Of recent, technological advances in wireless networking, microelectronics integration and miniaturization of sensors, is really helping in better information transfer and exchange, therefore, modernizing and changing the way health care services are deployed and delivered. The use of wearables for continuous health monitoring has gained focus in helping the transition to more proactive and affordable healthcare. They allow individuals to closely monitor changes in vital signs and provide feedback to help maintain an optimal health status [2]. In addition, these systems can even alert medical personnel when life-threatening changes occur. Human physiological parameters are an important reference in measuring the health status of people. Real-time monitoring plays an important role in the diagnosis and diseases treatment [3].

The underlying concept in this work is the construction of a wearable health monitoring device utilizing wireless network system to bringing ease to people who require constant check. It has advantages with its ability to keep in check the physiological signs sensed by the sensors on the wearable. The sensors communicate information to a mobile phone and the internet, therefore keeping patient, caregivers, and doctor informed while also establishing trends and detecting variations in health. The focus in this work is a wearable to track temperature and heart rate in infants.

II. PROCEDURE FOR PAPER SUBMISSION

A. Health Monitoring

Hospitals are exploring the wireless sensors technology to a range of applications which includes pre-hospital and in-hospital emergency care. This technology allows for vital signs to be recorded for quick analysis. These sensors permit home monitoring for chronic and elderly patients, facilitating long-term care and trend analysis; this in turn can sometimes reduce the length of hospital stays. Also, these sensors can be used for the monitoring of infants. Application areas include;

- Remote monitoring of physiological data
- Tracking and monitoring doctors and patients inside a hospital
- Drug administration
- Elderly assistance etc.

There really can be no monitoring without sensors.

Sensing in the world of health care until recently, was restricted primarily to hospitals. The first considered modern sensor was the first thermostat which emerged in 1883.

In 1995, wireless body worn sensors appeared in the health and wellness application. There is a clear transition from the time when sensors were based on specialized use to a general use among the public. Adoption has grown significantly in sport and wellness application. Continuous miniaturization of sensors and low-cost system on chips (SOCs) will continue to drive the future world towards maturing of the Internet of Things (IOT) as seen in fig. 1 [4].

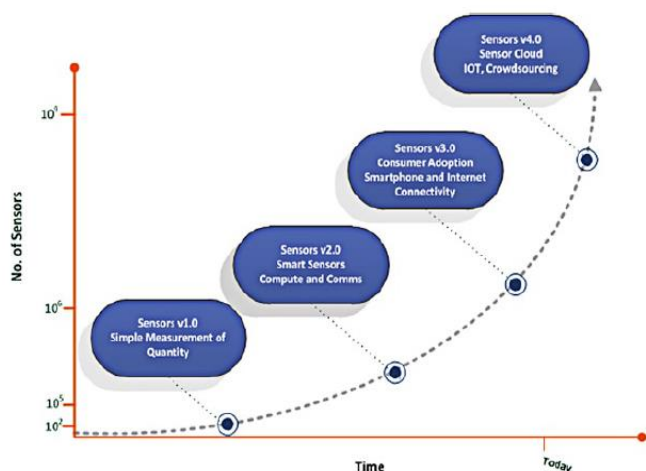

Fig. 1. Evolution of sensors reflecting the integration of ICT capabilities and consumer adoption.

The most familiar sensors in health application are those that measure vital signs specifically, body temperature, pulse rate (or heart rate), blood pressure, and respiratory rate. ABI research estimates that 5million of wearable vital sign sensors will be sold by 2018 [4].

B. Communication Technologies and Data Processing

Over the years different methods have been used for interfacing remote circuits. Currently, there are 3 main wireless standards used. Wi-Fi, Bluetooth and Zigbee. For the purpose of this project Wi-Fi technology will be used.

Wi-Fi – This is a radio technology set up to provide reliable, secure and fast wireless connectivity. It can be used to connect computers to each other as well as to the internet and other wireless networks. It works in an unlicensed 2.4ghz and 5ghz radio band, having a data rate of 11Mbps/s or 54Mbps/s. Wi-Fi cannot detect collision unlike Ethernet instead they use acknowledgement packets for every data packet sent.

Zigbee – Zigbee operates on the industrial, scientific and medical radio band with 868 MHz, 915 MHz, and 2.4 GHz in different countries [5]. It is a low-power, low cost wireless mesh network. As a result of its low-power it allows longer life and it has made the technology to be widely developed in wireless monitoring applications and its mesh network provides high dependability and large range [6].

Bluetooth – Bluetooth technology was designed to support simple wireless networking of personal consumer devices including PDAs, cell phones, and every wireless headset. It uses low-power radio communication. It covers short distances mainly up to 10 meters. They generally communicate at less than1Mbps in data transmission. Many researchers have used Bluetooth for their monitoring system.

C. Related Works

Li et al. [7] displays a useful and tangible user interface providing physical therapy for children with movement disorders.

Westeyn et al. [8] with its idea to put sensors in “smart toys” to detect and record interactions for monitoring the developmental progress of children.

Advanced Medical Monitor Project (AMON) - The AMON project major aim is to largely remove restrictions brought on the patients due to their condition and is faced with the construction of a wearable medical monitoring computer that provides complex monitoring, data analysis and capabilities in a single device.

“HealthGear” by Oliver et al. [9] describe wearable sensors which allow real-time sleep monitoring of blood oxygen level and pulse.

The Proe-TEX project – This project carried out as part of the FP6 program of the European Commission is another example in relation to safety monitoring application. It resulted in the development of smart garments to monitor emergency disasters.

III. SYSTEM DESIGN AND METHODOLOGY

This system consists of the sensors for vital signs, the function of the sensors and its peripheral components are as shown in the block diagram in fig. 2, while fig. 3 gives more details on this.

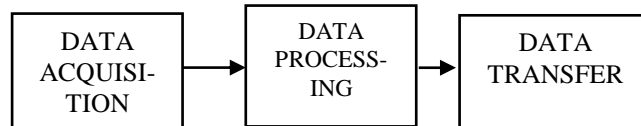

Fig. 2. Sensor Functions Block diagram

In data acquisition, the collection of vitals data is done by the temperature sensor and heart rate sensor. The temperature sensor takes the temperature of the person when it comes in contact with the body from the wearable and passes the record for processing. The heart rate sensor also takes readings on contact with the person and then sends records for processing.

Data processing is done by the Arduino which reads the records coming from the sensors and then converts into calibration that can be understood.

In data transmission, the Wi-Fi connection module makes the connection possible to the cloud server which can later be viewed on the application when there is an update in the vitals of the child.

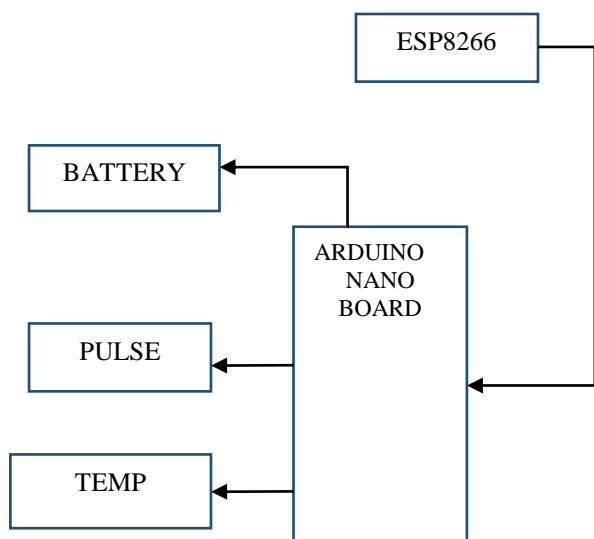

Fig 3: Block diagram of system

This system also uses the Thingspeak platform; its features include: – Open API, Real-time data collection, Geo-location data, Data processing, Data visualizations, Device status messages, e.t.c.

Android studio IDE – Android studio offers features that enhances productivity when building applications. They include;

- A fast emulator
- A unified environment where you can develop to all android devices
- Extensive testing tool and frameworks
- Instant run and push change to already running application without building a new APK Etc.

The Android application developed for the viewing of the sensed vitals is as seen in fig. 4. Fig. 5 on the other hand shows the developed system at a glance using the flowchart.



Fig 4: Android APP (Vita track)

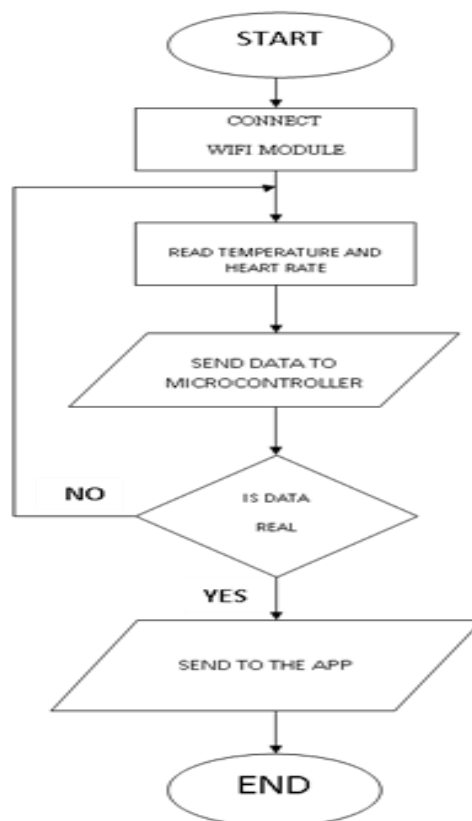

Fig. 5. System Flowchart

IV. IMPLEMENTATION AND TESTING

Figures 6-8 below shows the actual design steps and development carried out in this work.



Fig. 6. Prototype



Fig. 7. Packaged device (The Wearable)

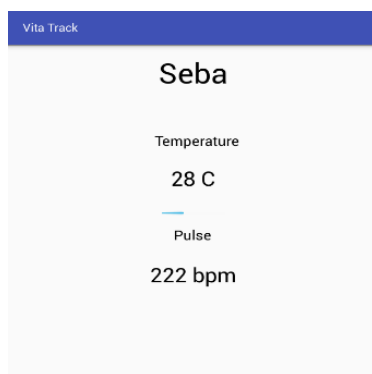

Fig. 8. Application interface

The vitals are viewed on the application when updates are sent, and these updates are renewed with a 15 seconds interval. With the use of the cloud server we are able to continuously save data without issues of memory.

V. CONCLUSION

We have presented a remote health monitor for children and considered its viability with respect to acceptability. Its design is comfortable, it is affordable and permits easy movement. It allows series of physiological measurements to be carried out. This work has shown that health monitoring with remote sensors while living the regular play child is feasible and should be looked into for further advancement. From the positive result on the work a further drive to include more sensors that will present a continuous check on the total well-being of the child and reduction in the size of the device while improving the accuracy and reliability is been investigated.

REFERENCES

- [1] R. Paradiso, "Wearable health care system for vital signs," plato, 2003.
- [2] A. Milenković, C. Otto and E. Jovano, "Wireless Sensor Networks for Personal Health Monitoring;," Huntsville.
- [3] L. Zhoua and Q. Laib, "Design and Implementation of Remote Health Monitoring Sensor Network based on," in AASRI International Conference on Industrial Electronics and Applications, 2015.
- [4] D. M. J. McGrath, D. C. N. Scanaill and D. D. Nafus, Sensor technologies Healthcare wellness and environmental applications, ApressOpen.

- [5] P. D.-I. A. Sikora, "ZigBee Competitive Technology Analysis," ZigBee organization, [Online]. Available: <http://www.zigbee.org/en/resources/whitepapers2.asp>.
- [6] N. N. F. A. B. C. HAMID, "HEALTH CARE MONITORING USING WIRELESS SENSOR NETWORK," Malaysia , 2012.
- [7] Li, Y., Fontijn, W., and Markopoulos, P. A tangible tabletop game supporting therapy of children with cerebral palsy. LNCS '08, (2008), 182–193
- [8] Westeyn, T.L., Abowd, G.D., Starner, T.E., Johnson, J.M., Presti, P.W., and Weaver, K.A. Monitoring children's developmental progress using augmented toys and activity recognition. Personal and Ubiquitous Computing 16, 2 (2012), 169–191.
- [9] Oliver, N. and Flores-Mangas, F. HealthGear: A realtime wearable system for monitoring and analyzing physiological signals. Pro. of BSN '06, (2006), 61–64
- [10] Patel, S., Park, H., Bonato, P., Chan, L., and Rodgers, M. A review of wearable sensors and systems with application in rehabilitation. Journal of NeuroEngineering and Rehabilitation 9, 2012, 21.