



The Thermal Analysis of Fuel Fired Crucible Furnace Using Autodesk Inventor Simulation Software

A. A. Abioye^{1,2}, P. O. Atanda², O. F. Kolawole¹, O. E. Olorunniwo²,
A. R. Adetunji^{1,2}, O. P. Abioye² and K. J. Akinluwade^{1,3*}

¹Department of Engineering, Prototype Engineering Development Institute, Ilesa, National Agency for Science and Engineering Infrastructure, NASENI, Nigeria.

²Department of Materials Science and Engineering, Obafemi Awolowo University, Ile-Ife, Nigeria.

³Department of Materials Science and Engineering, African University of Science and Technology, Abuja, Nigeria.

Authors' contributions

This work was carried out in collaboration between all authors. Author AAA designed the study, carried out the research, wrote the protocol and wrote the first draft of the manuscript. Author OFK performed the modeling. Authors OEO and OPA did the data analysis. Author KJA did the literature searches. Authors POA and ARA supervised the study and interpreted the results. All authors read and approved the final manuscript.

Article Information

DOI: 10.9734/AIR/2015/16235

Editor(s):

(1) Martin Kröger, Professor Computational Polymer Physics, Swiss Federal Institute of Technology (ETH Zürich), Switzerland.

Reviewers:

(1) Anonymous, Anna University (GKM CET), India.

(2) Anonymous, Middle East Technical University, Turkey.

Complete Peer review History: <http://sciencedomain.org/review-history/9959>

Original Research Article

Received 17th January 2015

Accepted 19th May 2015

Published 29th June 2015

ABSTRACT

The reasons for failure of locally made furnace in the foundries were as a result of cycles of operating temperatures that they were subjected to, which caused thermal stress and strain on the furnaces. This paper studied the simulation of thermal analysis of Fuel fired Crucible Furnace to predict the effect of thermal stress and strain on it.

Keywords: Thermal stress; thermal strain; simulation; thermal analysis; crucible furnace.

*Corresponding author: E-mail: jakinluwade@yahoo.com;

1. INTRODUCTION

Furnace is a term used to identify a closed space where heat is applied to a body in order to raise its temperature. The source of heat may be fuel or electricity. Commonly, metals and alloys and sometimes non-metals are heated in furnaces. The purpose of heating defines the temperature of heating and heating rate [1]. A furnace is an apparatus in which heat is generated and transferred directly or indirectly to a molten or solid mass for the purpose of effecting a physical, chemical or metallurgical change in the mass [2]. Furnace is equipment isolated from the surrounding by an insulated wall and is used to transfer heat to the material to be melted or heat treated within the furnace [3]. An ideal furnace is one in which all energy produced is utilized, this practically unachievable and there is no thermal processing equipment with efficiency of 100% [4]. A furnace of high efficiency is therefore a system in which energy losses are minimal. In practice, however, a lot of heat is lost in several ways. The losses include energy conversion losses, furnace wall losses, furnace opening losses and the likes [5]. In order to prevent these losses, materials that can retain and conserve heat known as refractory materials are therefore used as lining materials for the furnaces. Refractories are porous, multi-component and heterogeneous materials composed of thermally stable mineral aggregate, a binder phase and additives [6]. Refractory wall of furnace is a key component which is used as insulation layer.

Temperature change causes thermal stress and strain. Usually furnace designs are made of different parts of different materials, the materials expand as temperature increases and contract as it decreases which can lead to thermal fatigue causing cracking of the fuel fired crucible furnace linings. Restriction of thermal strain cause thermal stress. The design of fuel fired crucible furnace involves parts made of more than one material. When a structure is heated or cooled, it deforms by expanding and contracting. If the deformation is restricted as a result of displacement constraint or opposing pressure, thermal stress is induced in the structure. Thermal stresses also occur due to non uniform deformation as a result of different coefficients of thermal expansion in different materials in the structure. One major limitation of ceramics is their inherent brittleness that can result in catastrophic failure under severe thermal shock loads. For ceramics in high temperature applications such as fuel fired crucible furnace,

one may specifically design the material to reduce thermal stresses when subjected to a thermal shock [7].

From literature, the thermal stress distribution has been calculated in induction furnace, by determining the temperature distribution from the thermal analysis. In this, the materials which were less in temperature would be reluctant for the expansion and hence prevented the expansion of the layers of material with higher temperature. This restriction induced the stress in the material of the induction furnace. The different layers of the induction furnace wall having different materials resulted in the different thermal coefficient of expansion. The variance of thermal expansion also induced the thermal stress [8].

2. METHODOLOGY

2.1 Theoretical Analysis and Modelling of Fuel Fired Crucible Furnace

The major criterion in the development of the fuel fired crucible furnace was to ensure minimum heat losses from the furnace to the surrounding. Adequate insulation was provided to achieve this and also to optimize the furnace efficiency [9]. The rate of heat transfer across the crucible furnace depends on the thermal properties of the refractory material and the interface characteristics.

When a temperature gradient exists in a body, there will be energy transfer from the region of high temperature to low temperature region. The energy transferred by conduction and the heat transfer rate per unit area is proportional to normal temperature gradient;

$$\frac{q}{A} \propto \frac{dT}{dx} \quad (1)$$

When constant of proportionality is introduced, we have

$$\frac{q}{A} = -kA \frac{dT}{dx} \quad (2)$$

Where; q is heat transfer rate, (dT/dx) is temperature gradient in the direction of flow and k is thermal conductivity of the material

The equation 2 above is called Fourier's law of heat conduction.

Fourier's law can be redefined when heat flow across the wall as

$$Q = -kA \frac{dt}{dx} = -\frac{kA(t_2-t_1)}{1} = (t_2 - t_1)/(1/kA) \quad (3)$$

Where $dt = t_2-t_1$ and $dx = 1$. The term $1/kA$ is called thermal resistance

For the case of this fuel fired crucible furnace, the capacity of the furnace to be developed was 200 kg. Knowing the density of the charge which was copper to be 8920 kg/m^3 , in order to obtain crucible pot of that capacity, a compressor boiler plate or refrigerator condenser's cylinder with the height (h) of the cylinder 500 mm, the diameter (d), 161 mm and thickness (t) of 28 mm was used. Substituting these values into the equation 4 below, the volume of crucible pot was calculated to be 0.0278 m^3 ; since the volume of the crucible pot and the density of the copper charge were known, the mass of the copper charge that the crucible pot could contain was calculated using equation 5.

$$V = \pi r^2 h \quad (4)$$

Where, v is the volume of the crucible pot, r is the radius of the crucible pot and h is the height of the crucible pot

$$\rho = \frac{m}{v} \quad (5)$$

Where; ρ is the density of the charge and m is the mass of the charge

For the furnace to have good heat retention and to be able to accommodate the crucible pot of that capacity, the height (L) of the furnace must be well above the crucible pot which was assumed to be 760 mm to create allowance for furnace cover. The required operating temperature (T_i) for the furnace was assumed to be 1473K and the outside temperature (T_o) of the furnace shell was assumed to be 348.6 K. The thickness of the mild steel sheet used was 5mm. In order to be able to achieve the above temperatures, the thickness of the refractory lining was calculated using cylindrical heat transfer equation in equation 6 below.

$$\frac{T_i-T_o}{Q} = \frac{\ln(R_1/R_i)}{2\pi L K_a} + \frac{\ln(R_2/R_1)}{2\pi L K_b} + \frac{\ln(R_3/R_2)}{2\pi L K_c} + \frac{\ln(R_4/R_3)}{2\pi L K_d} + \frac{\ln(R_5/R_4)}{2\pi L K_e} \quad (6)$$

Q is the quantity of heat supplied which was assumed to be 1.67 KW

K_a, K_b, K_c, K_d and K_e are the thermal conductivities of copper, crucible pot (mild steel), dry air, and furnace shell (mild steel) respectively.

R_i, R_1, R_2, R_3, R_4 and R_5 are radial distance of the crucible furnace, copper charge, crucible pot, flame gap, refractory lining and furnace shell respectively.

Substituting the above values inside the equation 6, a lining of uniform thickness 70 mm was arrived at to give a monolithic refractory structure. The clearance between the crucible pot and refractory lining of the furnace shell was the space left after the refractory lining has been determined. This clearance was the flame gap where the flame from the fuel combustion would have a direct impact on the crucible pot for the melting of the charge. From the theoretical analysis of the furnace above, the following specifications were obtained for the design of the furnace.

- The Total height of the crucible furnace = 760 mm
- The height of the crucible body = 610 mm
- The height of the crucible cover = 150 mm
- The diameter of the crucible = 577 mm
- The thickness of the kaolin lining= 70 mm
- The flame gap = 57.5 mm
- The radius of crucible pot = 161 mm

The modeling of the fuel- fired crucible furnace to be constructed was done using Autodesk® Inventor software. The software was used because of its flexibility and ability to give a detailed design over AutoCAD® software. The models of the furnace to be constructed were shown in Figs. 1 to 4, these Figures represent the geometric view of the furnace, the exploded view showing parts of the furnace, the 2D of the crucible furnace with dimensions and the crosssectional view of the furnace respectively.



Fig. 1. Geometric view of the crucible furnace [6]

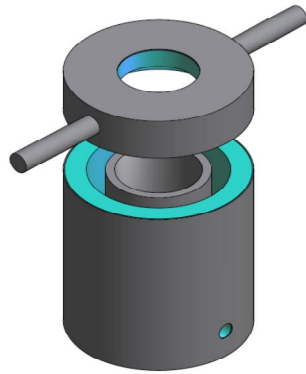

Fig. 2. Exploded view showing part of the crucible furnace [6]

The crucible furnace was made up of four units: The furnace wall, which was made up of mild steel sheet of 5 mm thickness, the lining materials, the flame gap and the crucible pot. The function of the furnace shell was to provide housing for the refractory lining and the crucible pot. The objectives of the furnace shell were to provide rigidity, strength, ease of fabrication, ability to carry its own weight and that refractory linings and crucible pot and ability to retain high strength even after shaping [10]. The function of the furnace refractory was to reduce heat loss in the furnace. The objectives of the refractory were determined considering factors environmental condition, furnace requirement and the expected length of service [11]. Each units were made up of different materials; mild steel, kaolin and air at the flame gap. These materials have different coefficients of thermal expansion, also the design of furnace is such that the expansion of the furnace lining is restricted by displacement constraint; the furnace shell. As a result of these factors coupled with non uniform heat distribution, there will be non uniform deformation that will induce thermal stress in the furnace.

Two design scenarios were created for the thermal analysis of the fuel fired crucible furnace. The first design scenario simulated the temperature distribution and heat flux. The second design scenario simulated thermal displacement, Von Mises thermal strain and stress. One quarter of the crucible furnace was modeled on Autodesk® Inventor 2014 as shown in Fig. 5; the reason was to reduce mesh density and computation time. The one quarter model was imported into Autodesk® simulation multiphysics 2013 using steady state heat transfer analysis.

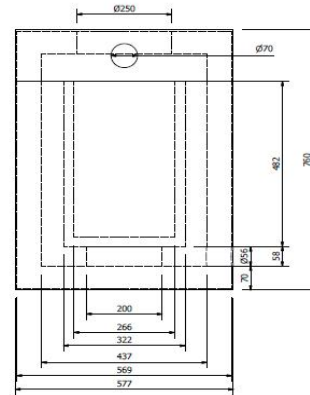

Fig. 3. 2D of crucible furnace with dimension

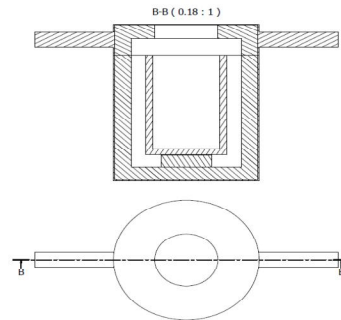

Fig. 4. Crosssectional view of the crucible furnace

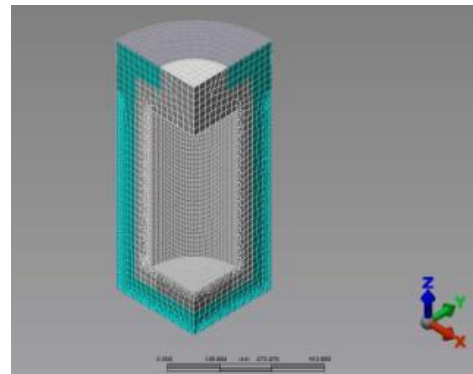

Fig. 5. One quarter mesh of the crucible furnace

Materials were then assigned to individual component such as mild steel to furnace shell and crucible pot, kaolin to furnace lining and air to flame gap. The material properties were as shown in the Table 1. Specific heat capacity of the materials was not required since the simulation was done in a steady state and not transient. A mesh size of 1 mm was chosen

because the smallest component was 5 mm thick that gives a total of 5 mesh division across the smallest component. Brick elements with mid side nodes were chosen. The boundary conditions; the temperature of 1473K was applied to the flame gap, the surface convection load of 25 J/sKm² with ambient temperature 348.4 K was also applied to the furnace surrounding. The simulation was run and the temperature distribution and heat flow were generated as shown in Figs. 6 and 7. A second design scenario was created using static stress with linear material model to study the thermal effect on the fuel fired crucible furnace. Keeping materials and mesh constant as in design scenario 1 two symmetry constraint was added along the YZ and XZ plane (because of one-quarter model). The model was stabilized at the base using 3D spring support, and then the thermal load obtained from the design scenario 1 was mapped into the model with gravity acting in negative Z direction. Figs. 8, 9 and 10 shows the results obtained for thermal displacement, stress and strain.

maximum temperature of 1529.655 K at the flame gap region of furnace and the minimum temperature of 274.838 K would be at some region of the furnace shell. The crucible pot would experience temperature range 1278.691 K- 1529.655 K. The kaolin refractory would offer a very good insulation going by the temperature distribution result in Fig. 6.

The heat flux would be built in the crucible pot with the maximum flux 7.43699 x 10⁶ J/m²s at the base edge of the crucible pot. Uniform minimum heat flux 415.575 J/m²s would be experienced at the flame gap and the refractory linings. As shown in Fig. 7.

In Fig. 8, the crucible pot would experience maximum thermal displacement and some displacement at the furnace cover. The thermal strain would be maximum at the base edge of the crucible pot and the edge of the furnace cover (where there are joints), also thermal strain would also be experience at the surface of the furnace lining as shown in Fig. 9.

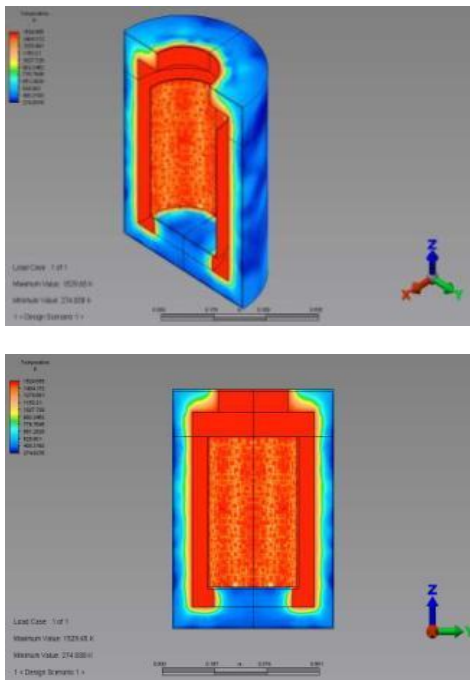

Fig. 6. 3D and 2D temperature distribution of the fuel fired crucible furnace

3. RESULTS AND DISCUSSION

It could be seen that the temperature distribution for the fuel fired crucible furnace Fig. 6 has

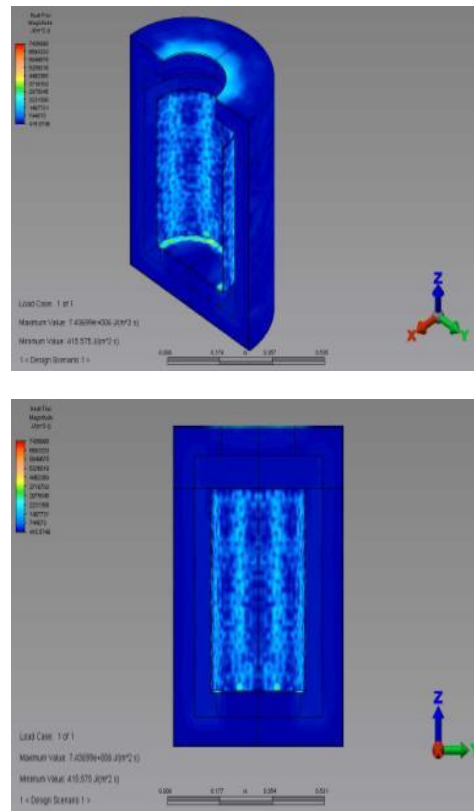

Fig. 7. 3D and 2D total heat flux of the fuel fired crucible furnace

Table 1. Material properties for the component parts of fuel fired crucible furnace

Materials	Mass density (Kg/m ³)	Thermal conductivity (J/smK)
Mild Steel	7860	56
Kaolin	2630	4
Air	1.2	0.025

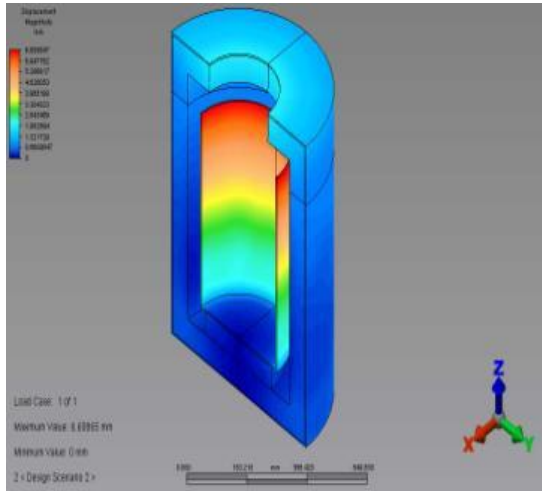

Fig. 8. 3D Thermal displacement of the fuel fired crucible furnace

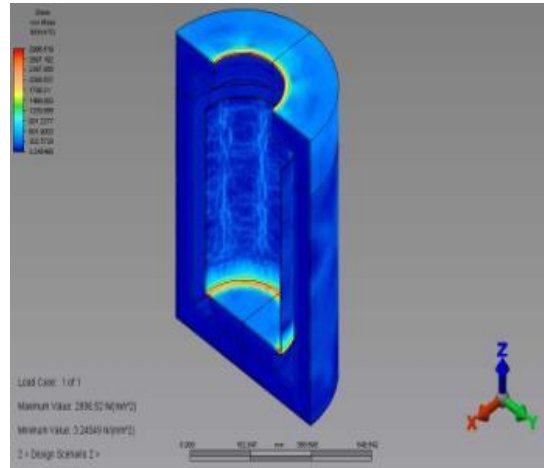

Fig. 10. 3D Von mises stress of the fuel fired crucible furnace

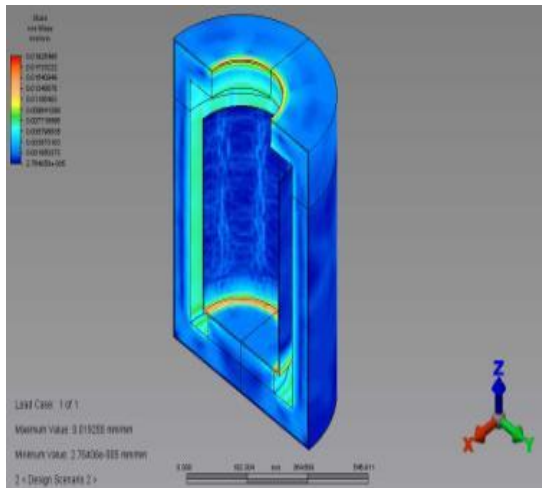

Fig. 9. 3D Von mises strain of the fuel fired crucible furnace

The thermal stresses would be experienced in the furnace with the maximum value at the base edge of the crucible pot and the inner edge of the furnace cover where thermal strains were experienced as shown in Fig. 10.

4. CONCLUSION

The kaolin refractory lining would offer a suitable thermal insulation for the fuel fired crucible furnace. The thermal displacement on the crucible pot was due lack of constraint at the top of the crucible pot. This might limit the life duration of the pot when subjected to constant of melting of charge. The failure of the crucible pot would start at the base edge of the pot due to the thermal stress constraint which would lead to maximum thermal stress at the base edge; likewise failure would also be experienced at the inner tip of the furnace cover due to the above reason. The crucible pot could be change if failure was noticed. At the prevailing temperatures the refractory lining could withstand the thermal stress, with this thermal analysis it could be predicted that the designed fuel fired crucible furnace would perform optimally with little deformation at the crucible pot and furnace cover.

COMPETING INTERESTS

Authors have declared that no competing interests exist.

REFERENCES

1. Mehta NC, Raiyani AD, Gondalia VR. Thermal fatigue analysis of induction melting furnace wall for silica ramming mass. International Journal of Emerging Technology and Advanced Engineering. Available: www.ijetae.com (ISSN 2250-2459, ISO 9001:2008. Certified Journal. 2013;3(2).
2. Gilchrist JD. Fuels, furnaces and refractories. Pergamon Press; 1997.
3. Etherington H, Ehtering G. Modern furnace technology 3rd Ed. Charles Griffin and Company Ltd, London; 1961.
4. Atanda PO. Development of integrated salt bath isothermal heat treatment furnace unit for Austempering Ductile Iron. Ph.D. Thesis Project. Obafemi OAU Ile Ife Nigeria; 2009.
5. Trinks W. 'Industrial Furnaces'. John Wiley and Sons Inc; New York. 1967;1 and 2.
6. Atanda PO, Abioye AA, Olorunniwo OE, Oluwole OO. Material selection for the fuel fired crucible furnace using GRANTA. International Journal of Scientific & Engineering Research. 2014;5(7):615 ISSN 2229-5518.
7. Jin ZH, Paulino GH. Transient thermal stress analysis of an edge crack in a functionally graded material. International Journal of Fracture. 2001. © 2001 Kluwer Academic Publishers. Printed in the Netherlands. 2001;107:73–98.
8. Nihar PB. Finite element analysis of induction furnace for optimum heat transfer. International Journal of Innovative Research in Science, Engineering and Technology. 2013;2(5). ISSN: 2319-8753.
9. Atanda PO, Olorunniwo OE, Abioye AA, Oluwole OO. Modeling heat flow across fuel-fired crucible furnace using ADINA. International Journal of Scientific & Engineering Research. 2014;5(7):608. ISSN 2229-5518
10. Degarmo EP, Black JT, Ronald AK. Materials and processes in manufacturing 8th ed., Prentice Hall of India Private Ltd, New Delhi-110001; 1997.
11. Gupta OP. Elements of fuels, furnaces and refractories. Khanna Publishers, India; 1997.

© 2015 Abioye et al.; This is an Open Access article distributed under the terms of the Creative Commons Attribution License (<http://creativecommons.org/licenses/by/4.0>), which permits unrestricted use, distribution, and reproduction in any medium, provided the original work is properly cited.

Peer-review history:

The peer review history for this paper can be accessed here:

<http://sciencedomain.org/review-history/9959>