

A Wireless RFID-Based Document Management System

Victor O. Matthews, Etinosa Noma-Osaghae, Uzairue Stanley Idiake, Ireoluwa Obatoki

¹Department of Electrical and Information Engineering, Covenant University, Ota, Ogun State, Nigeria.

Email: victor.matthews; etinosa.noma-osaghae; stanley.uzairue; ireoluwa.obatoki(@covenantuniversity.edu.ng)

ABSTRACT

It is virtually impossible to do away completely with papers, files, folders and cabinets. A lot of essential services (e.g. legal and healthcare services) demand that written or printed copies of certain documents be carefully and orderly kept. But these files are regularly retrieved and updated. It becomes highly inefficient and time consuming to retrieve these files from where they are kept when their numbers become very large. This paper proposes the use of a low-cost Radio Frequency Identification (RFID) mechanism to manage documents filed and stored in shelves and cabinets. The proposed system makes use of a passive RFID tag and an interrogator. Radio signals in the low-frequency range (125 KHz) delivered inventory rounds (commands) that aid the speedy and timely retrieval of any file from a very large pool of others. The designed and implemented system worked perfectly well with a satisfactory modulation depth of 100% and a read range of two (2) meters.

Keywords : Component; Formatting; Style; Styling; insert (keywords)

1 INTRODUCTION

The twenty first century has brought with it a keen sense of the importance of time. Multinational corporations, small and medium scale enterprises all want more time to do business and make greater profits. One of the keys to the greater productivity that can translate into higher profits for businesses is the way files are stored and retrieved. Organizations that have not been able to devise a means of storing and retrieving documents in a timely and efficient manner end up having internal (employee and manager) and external (clients) conflicts. The loss of valuable time due to an inefficient file management system for hard copies of files almost always results in loss of revenue and slow organizational growth [1] [10].

The utmost need for some information to be written or printed on papers and properly kept makes the need to a timely and efficient method for retrieval very important. Businesses grow and this causes the amount of information they store on papers to increase exponentially. A "drag" in the speed of business transactions will become more evident if a way to efficiently manage this large amount of document is not found [11]. The average worker uses 10,000 sheets of copy paper yearly. When multiplied by the number of workers in the company, it gives a very startling value. Offices and Institutions around the world use and store important documentations of their work every day and employees constantly need to retrieve this information from stored files. As member of such a corporate body, are you able to find that report you need for your meeting in five minutes? It depends on the type of search system used in your company [12]. This paper proposes the use of RFID tag and an interrogator (reader) to manage the storage and retrieval of documents in a timely and efficient manner. The proposed system makes use of a microcontroller that interprets the inventory rounds sent to it by the RFID reader. Each folder is given an RFID tag that contains all the essential information needed to correctly identify the files con-

tained in every folder [2] [13].

2 LITERATURE REVIEW

Implementation of RFID solutions in various units of the organization is slowly gaining ground in many of today's big organizations. The following case studies expatiate on current happenings and mirror the implementation of RFID solutions as described in this paper [3] [14].

The use of RFID is so pervasive that many organizations like Lhermet Labigne & Remy (LLR), a French law firm with a staff strength of about forty sees the need for it. The law firm, a custodian of over thirty thousand intellectual property and patent documents that increases by not less than six thousand every year had to employ the use of RFID technology to manage its files. At a time the firm could not efficiently handle clients' files because of the huge number of documents in its care. In fact retrieving clients' files was a very cumbersome and inefficient process [15]. Clients began to express dissatisfaction with the way their files were being handled because locating a file could take several days. Implementing an efficient RFID file management system within the firm greatly improved her productivity. All the firm did was to attach a paper-thin adhesive RFID tag to each file and with a portable tag reader, relay all details about each file to a programmable station. This made it possible for clients' file to be located efficiently, reliably and in a timely manner [4] [16].

RFID technology has been used to manage waste disposal. The collection and disposal of waste can be a very inefficient process. The waste disposal process is inefficient if waste bins are emptied regularly and irrespective of whether they are full or not. Waste disposal trucks are forced to make unneeded trips to neighbourhoods with no present need for any waste disposal service because there is no way to know ahead of time if the neighbourhood in question has a present need for

waste disposal service. The use of RFID technology has helped to optimize waste disposal truck routes and save waste disposal firms a lot in fuel, time and money. A typical example of an RFID-based waste disposal system is the Pay-as-you-throw (PAYT). The customer in this system is charged based on the number of times a waste disposal service is ordered. The unit charge is fixed by weight and volume. This type of RFID assisted waste management scheme has been implemented in several nations. It has proven to be fair, efficient and practicable [5] [17].

Implementation of RFID solutions have been proven by existing literature to deliver speedy positive Return-on-Investment. This is even made better by the fact that RFID technologies are extremely flexible and can be tailored to provide customer-specific solutions. RFID solutions help to reduce costly human errors and workplace bottleneck. Virtually any organizational process can be improved with RFID-based solutions. The hallmark of deploying RFID-based solutions is the savings it brings to organizations in time and costs [6] [18].

Today, RFID technology is being combined with mobile computing to deliver premium ways of identifying and managing assets to organizations [7] [19]. When combined with RFID technology, mobile computing can provide the tools needed to do away with any form of paper-work, prevent the loss of important assets and documents, and take attendance. The combination of mobile computing with RFID technology has provided firms with a reliable means of monitoring their assets in real-time and minimizing theft [8] [20]. Financial institutions are not left out of the current trend and have plugged into it. Financial institutions have even developed standards for tagging assets that are being implemented in other industries [9]. The most basic operation of any RFID-based system is illustrated in Figure 1.

3 METHODOLOGY

The main parts of the RFID-based document management system are the microcontroller, interrogator (reader) and RFID tags. Other parts of the system include the LCD display and the power supply unit. The block diagram used to realize the proposed RFID-based document management system is shown in Figure 2.

It consists of the digital/control section, the Radio Frequency (RF) section and the antenna. The digital section of the interrogator reader processes the signals received from the RFID tags (transponder). The digital section of the interrogator has a microprocessor, memory block, analogue-to-digital converter (ADC) and an enabling software application. The RF section is used to transmit and receive inventory rounds (commands). It operates at a frequency of 125 KHz. The passive RFID tag is "awakened" (electromagnetic coupling effect) by the inventory rounds (modulated radio waves) sent to it by the interrogator. The RFID tag "re-modulates" the radio wave and sent to it by the interrogator and "re-radiates" (through a process called backscattering) it back to the interrogator's antenna.

To send a logic '0' to the RFID reader (interrogator), the tag requests for more power from the reader. This causes a small voltage drop on the RFID reader's side. The voltage drop

represents logic "0". When the tag does not require any additional power there will be no voltage drop on the interrogator's side. This represents logic "1".

The read distance between the RFID tag and the reader is dependent on the turns of the reader's coil. When the RFID tag is placed in the read distance of the interrogator, it will read the 10-digit unique ID of the tag and transmit it as ASCII characters through its serial output and via an antenna whose resonating frequency, gain, directivity and radiation pattern can a determine read distance. The Reader module transmits at 125kHz, has a Baud rate of 9600, operates at a voltage level of 5V.

RFID solutions in various units of the organization is slowly gaining ground in many of today's big organizations. The following case studies expantiate on current happenings and mirror the implementation of RFID solutions as described in this paper [3] [14].

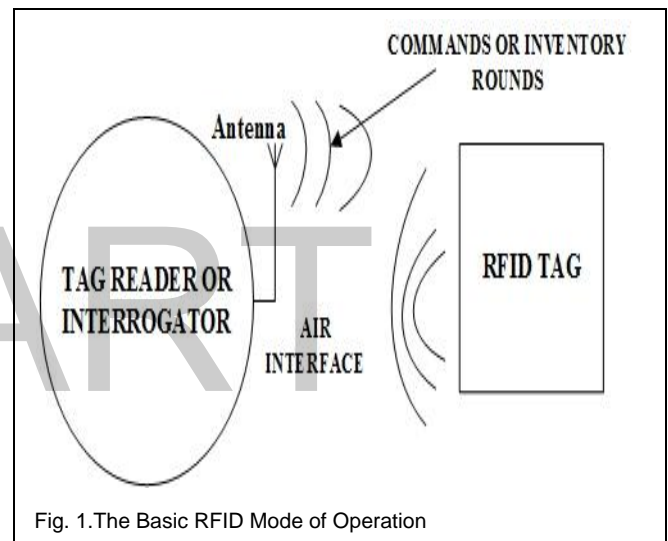

Fig. 1. The Basic RFID Mode of Operation

6.1 How the System Works

A Voltage Regulator regulates the input voltage to 5V. The current enters the first LED and lights it to indicate that there is power supply. The RFID Reader module is connected to the 5V power from the regulator. A second LED lights up to show that the reader is powered on. Once the reader is powered on, oscillating movement occurs between its Inductor and capacitor, in this case, 125000 times a second. Hence, it emits 125 KHz Low Frequency energy into its surroundings and creates a magnetic field. The tag when brought in close proximity to this field is "awakened" due to a phenomenon called Inductive Coupling.

The tag consists of a silicon device and an antenna which has a resonant LC circuit connected to it. It is this resonant circuit that both receives the modulated RF energy from the reader and "re-radiates" the "re-modulated" RF signal (backscatter signal). When the reader receives the modulated backscatter signal, it decodes the signal. The decoded signal is sent to the serial communication port of the microcontroller. The microcontroller uses a 4MHz crystal to skip to each instruction in its memory. It responds to the input and sends the

required output to the LCD screen.

The source code that provides the blueprint by which the microcontroller functions is written using Micro Basic. First declarations are made so that the microcontroller stores variables in its memory which will be called during the execution of the program:

```
'declarations
dim txt as string [20]
dim txts as char [12]
dim A as char [12]
dim B as char [12]
dim CC as char [12]
dim DD as char [12]
dim delim as char[1]
dim n,i,temp,value as byte
dim Card as byte
```

The main function which comprises all the sub-functions which are called according to different inputs is written thus:

```
main:
  Usart_Init(9600)
  'Call LCD declerations and welcome message
  welcome
  delim = (" ")
  while true
    while Usart_Data_Ready = 0 wend
    'delay_ms(100)
    Usart_Read_Text(txt, delim)
    Lcd_Cmd(LCD_CLEAR) ' This sends a command to the
LCD to clear it's display
    Lcd_Cmd(LCD_CURSOR_OFF) 'This command
prevents the cursor from appearing on the screen
    GetID
    GetData
  wend
end.
```

The Sub function 'welcome' displays the first message that is shown on the screen once the device is turned on. The Sub function GetID is one of the most important. It declares the Identification numbers on each tag and instructs the microcontroller to display particular messages once it reads the number associated with it. For example, in the second line in the code below, Letters A to D which have correctly been declared in the previous code are represented with unique characters associated with each tag. In this case, four tags. 'CC' and 'DD' are used here to create a variation as Micro Basic already has inbuilt functions with 'C' and 'D'.

```
sub procedure GetID
'A = 7F9FF82 B = 79D2039 C = 80726AA D = 79C1109
A = "030087F9FF82"
B = "0300879D2039"
CC = "0300880726AA"
DD = "0300879C1109"
n = 0
for i = 0 to 11
```

```
txts [n] = txt [n+3]
inc(n)
next i
temp = 1
temp = Strcmp(txts,A)
if temp = 0 then
temp = 1
Card = 1
end if
temp = Strcmp(txts,B)
if temp = 0 then
temp = 1
Card = 2
end if

temp = Strcmp(txts,CC)
if temp = 0 then
temp = 1
Card = 3
end if
```

```
temp = Strcmp(txts,DD)
if temp = 0 then
temp = 1
Card = 4
end if
end sub
```

The Sub function: 'GetData' tells the microcontroller to display particular messages associated with each unique tag. The completed code is written into the microcontroller through an ICSP. This technology enables easy re-writing and improvement of the source code during the testing phase.

4 TESTING AND IMPLEMENTATION

When the user places the reader close to the "first folder" with an embedded 125KHz tag, it displays the message:

```
"Date Created:20/2/14
This Folder contains
File 1: Proposal for installation of AC's"
After 4 seconds:
"File 2: Proposal for FCDA project
File 3: Bid for NAFDAC project"
```

Placing the reader close to "another folder" has it display:

```
"Date Created:23/2/14
This Folder contains
File 1: Issuance Inc
File 2: Concordance"
After 4 seconds:
"File 3:Certification for Training 101
File 4:Certification for NACOSS training"
```

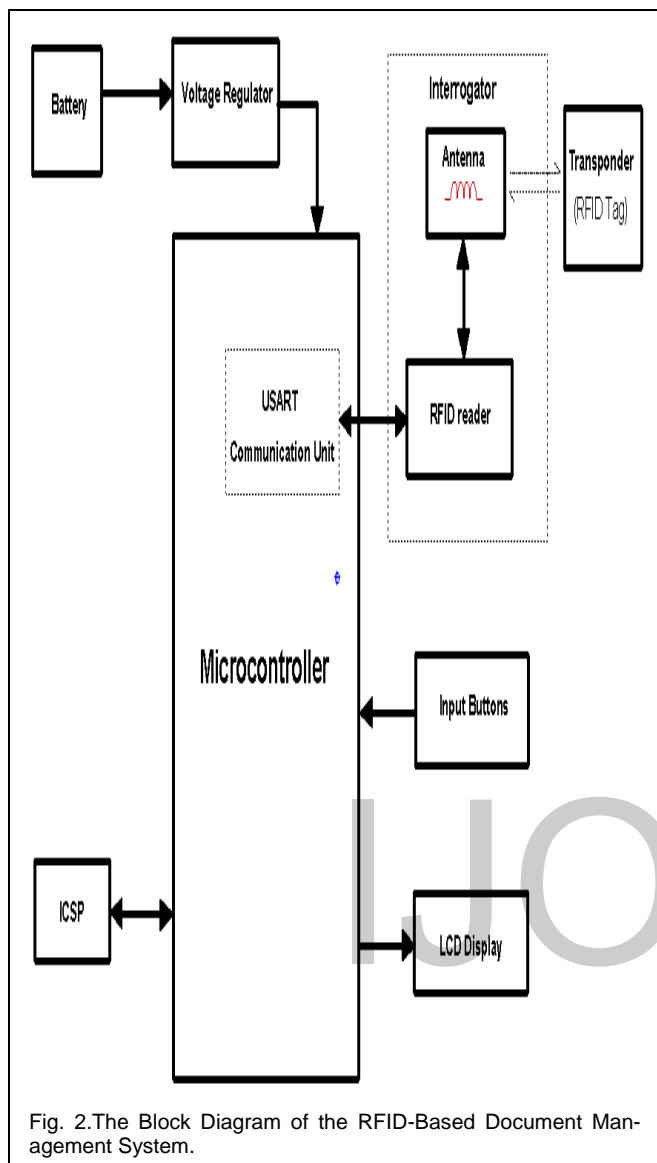

Fig. 2.The Block Diagram of the RFID-Based Document Management System.

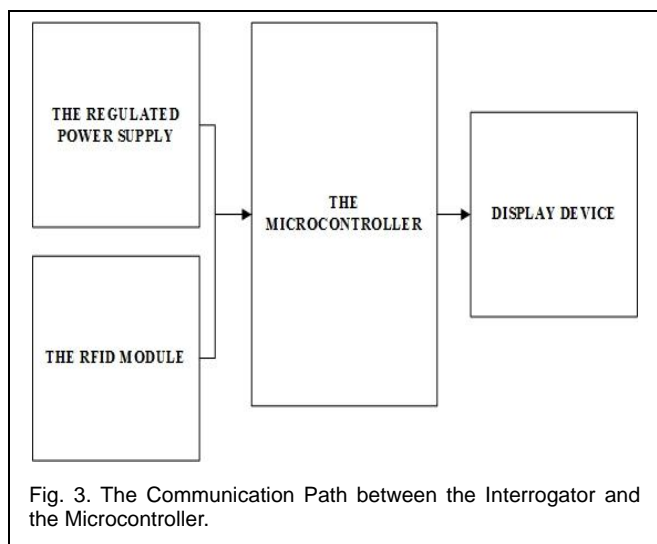

Fig. 3. The Communication Path between the Interrogator and the Microcontroller.

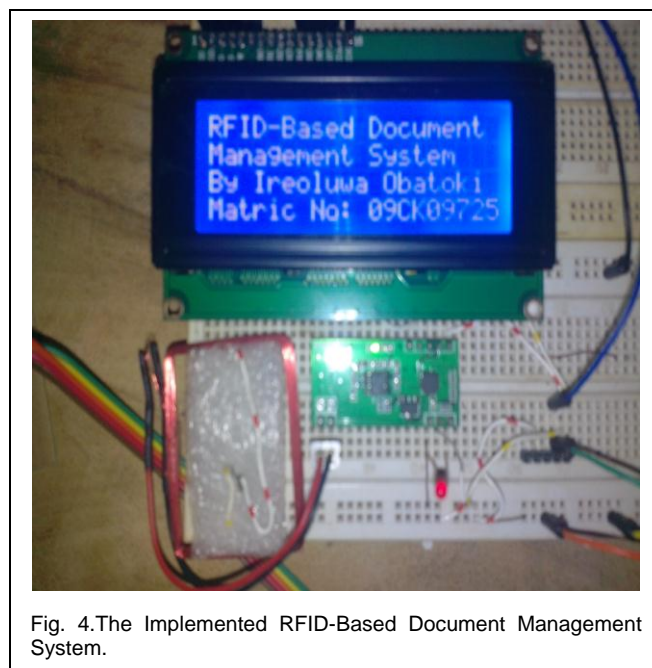

Fig. 4.The Implemented RFID-Based Document Management System.

The total power induced in the tag's antenna is given as:

$$P_{tag} = \left[\frac{P_t G_t}{4\pi r^2} \right] \left[\frac{\lambda^2}{4\pi} \right] G_{tag} \quad (1)$$

Where;

P_{tag} → Total power induced in tag's antenna

G_{tag} → The tag's antenna gain

λ → Wavelength

P_t → Transmitting antenna power

G_t → Transmitting antenna gain

r → The tag's antenna distance from the transmitting antenna

The re-radiated power:

$$P_{rr} = \left[\frac{4R_{tag}^2}{|Z_{tag} + Z_c|^2} \right] P_{tag} G_{tag} \quad (2)$$

$$K = \frac{4R_{tag}^2}{|Z_{tag} + Z_c|^2} \quad (3)$$

Z_{tag} → The impedance of the tag's antenna

Z_c → The impedance of the tag's chip inlay

R_{tag} → Length of the tag's chip inlay

P_{rr} → The re - radiated power

The read range:

$$Range_{rsad} = \sqrt[4]{\frac{EIRP}{P_{tag_min} G_{tag}}} \quad (4)$$

$$Range_{rsad} = \sqrt[4]{\frac{P_{tag} G_{tag_min} G_{recv_tag_min} \tau}{P_{tag_min}}} \quad (5)$$

EIRP → Equivalent Isotropic Power

τ → *K*

P_{tag_min} → Minimum tag antenna gain

$G_{recv_tag_min}$ → Minimum receiving (interrogator) antenna gain

P_{tag_min} → Minimum tag antenna gain

5 CONCLUSION

The proposed RFID-based document management system is relatively easy to implement and is not costly. It does not need an internet connection to operate. In fact, a calculation of the Return-on-Investment and Cost Benefit of using this proposed RFID-based document management system revealed emphatically, a large improvement in both savings and profits. The realized system has been proven to aid the seamless, efficient and timely retrieval of hard copies of documents that have been archived or stored.

6 ACKNOWLEDGEMENT

This paper is sponsored by Covenant University, Ota, Ogun State, Nigeria.

REFERENCES

- [1] H. Nguyen and M. Chew, "RFID-based attendance management system," in Recent Trends in Telecommunications Research (RTTR), Workshop on, 2017, pp. 1-6.
- [2] M. A. Brisebois, B. Drummond, A. Mehta, M. Chene, and M. Flannigan, "Method and system for customizing a mobile application using a web-based interface," ed: Google Patents, 2017.
- [3] P. Zumsteg and H. Qu, "Reading RFID tags in defined spatial locations," ed: Google Patents, 2018.
- [4] S. S. Srikant and R. P. Mahapatra, "Read range of UHF passive RFID," International Journal of Computer Theory and Engineering, vol. 2, p. 323, 2010.
- [5] B. Chowdhury and R. Khosla, "RFID-based hospital real-time patient management system," in Computer and Information Science, 2007. ICIS 2007. 6th IEEE/ACIS International Conference on, 2007, pp. 363-368.
- [6] T. Poon, K. L. Choy, H. K. Chow, H. C. Lau, F. T. Chan, and K. Ho, "A RFID case-based logistics resource management system for managing order-picking operations in warehouses," Expert Systems with Applications, vol. 36, pp. 8277-8301, 2009.
- [7] E. Ngai, F. Suk, and S. Lo, "Development of an RFID-based sushi management system: The case of a conveyor-belt sushi restaurant," International Journal of Production Economics, vol. 112, pp. 630-645, 2008.
- [8] J. H. Bowers and T. J. Clare, "Inventory system using articles with RFID tags," Ed: Google Patents, 1999.
- [9] F. Amouzegar and A. Patel, "Vehicle maintenance notification system using RFID technology," International Journal of Computer Theory and Engineering, vol. 5, p. 312, 2013.
- [10] K. O. Okokpujie, E. C. Chukwu, E. Noma-Osaghae, and I. P. Okokpujie, "Novel Active Queue Management Scheme for Routers in Wireless Networks," International Journal on Communications Antenna and Propagation (I. Re. CAP), vol. 8, pp. 53-61, 2018.
- [11] K. O. Okokpujie, A. Orimogunje, E. Noma-Osaghae, and O. Alashiri, "An Intelligent Online Diagnostic System With Epidemic Alert," An Intelligent Online Diagnostic System With Epidemic Alert, vol. 2, 2017.
- [12] K. Okokpujie, E. Noma-Osaghae, S. John, and A. Ajulibe, "An Improved Iris Segmentation Technique Using Circular Hough Transform," in International Conference on Information Theoretic Security, 2017, pp. 203-211.
- [13] K. O. Okokpujie, E. Noma-Osaghae, G. Kalu-Anyah, and I. P. Okokpujie, "A Face Recognition Attendance System with GSM Notification," 2017.
- [14] C. Atuegwu, S. Daramola, K. O. Okokpujie, and E. Noma-Osaghae, "Development of an Improved Fingerprint Feature Extraction Algorithm for Personal Verification," International Journal of Applied Engineering Research, vol. 13, pp. 6608-6612, 2018.
- [15] K. Okokpujie, E. Noma-Osaghae, S. John, and R. Oputa, "Development of a facial recognition system with email identification message relay mechanism," in Computing Networking and Informatics (ICCNI), 2017 International Conference on, 2017, pp. 1-6.
- [16] N.-O. Etinosa, C. Okereke, O. Robert, O. J. Okesola, and K. O. Okokpujie, "Design and Implementation of an Iris Biometric Door Access Control System," in Computational Science and Computational Intelligence (CSCI), 2017, Las Vegas, USA, 2017.
- [17] K. Okokpujie, E. Noma-Osaghae, S. John, and P. C. Jumbo, "Automatic home appliance switching using speech recognition software and embedded system," in Computing Networking and Informatics (ICCNI), 2017 International Conference on, 2017, pp. 1-4.
- [18] C. Atuegwu, K. O. Okokpujie, and E. Noma-Osaghae, "A Bimodal Biometric Student Attendance System," 2017.
- [19] K. Okokpujie, N.-O. Etinosa, S. John, and E. Joy, "Comparative Analysis of Fingerprint Preprocessing Algorithms for Electronic Voting Processes," in International Conference on Information Theoretic Security, 2017, pp. 212-219.
- [20] K. O. Okokpujie, N.-O. Etinosa, O. J. Okesola, J. N. Samuel, and O. Robert, "Design and Implementation of a Student Attendance System Using Iris Biometric Recognition," in Computational Science and Computational Intelligence (CSCI), 2017, Las Vegas, USA, 2017.