

Design and deployment of hybrid-telemedicine applications

Ikhu-Omoregbe, N.A., Atayero, A.A., Ayo, C.K. and Olugbara, O.O.
Department of Computer and Information Science, Covenant University
CanaanLand, Ota, Nigeria

{stnics@yahoo.com, atayero@ieee.org, ckayome@yahoo.com, olu_olugbara@yahoo.com}

ABSTRACT

With advances and availability of information and communication technology infrastructures in some nations and institutions, patients are now able to receive healthcare services from doctors and healthcare centers even when they are physically separated.

The availability and transfer of patient data which often include medical images for specialist opinion is invaluable both to the patient and the medical practitioner in a telemedicine session. Two existing approaches to telemedicine are real-time and stored-and-forward. The real-time requires the availability or development of video-conferencing infrastructures which are expensive especially for most developing nations of the world while stored-and-forward could allow data transmission between any hospital with computer and telephone by landline link which is less expensive but with delays.

We therefore propose a hybrid design of applications using hypermedia database capable of harnessing the features of real-time and stored-and-forward deployed over a wireless Virtual Private Network for the participating centers and healthcare providers.

KEYWORDS: Hypermedia database, Telediagnosis, Telemedicine, Stored-and-Forward

1. INTRODUCTION

Telemedicine can be seen as the provision of healthcare through a combination of telecommunications and multimedia technologies (live video and audio, static DICOM-encoded, medical images, text, graphics and vital signs) with medical expertise [1, 2].

In recent years the shortage of medical specialists has necessitated a growing interest for cost effective and efficient telemedicine tools for healthcare delivery. The advancement and reduction in cost of network technologies, using interactive audio and video, high resolution monitors, and fiber optics, are resulting in cost effective advantage to interactive communication technologies for improved healthcare services [3].

Telemedicine holds great promise to enhance healthcare delivery in rural areas and developing countries by allowing a physician or other healthcare specialists examine a patient while linked by video or other means to an expert consultant at a distant medical center [2]. Radiologists and other specialists can review medical images transmitted over telephone lines. Similarly, a Pathologist in a developed world can review biopsies done in a hospital in a rural or developing country while the patient is still under anesthesia. [2].

The rapid advances in digital technology have now made other media, particularly images and sound, amenable to computer-based storage, manipulation, and transmission. Multimedia database contain images, and video in addition to the textual information. The synchronization of media gives multimedia. Hypermedia is multimedia with links among the components and a mechanism for moving along the links [3]. Most image and video databases are indexed manually based on textual annotations. The MPEG-4 standards have made video compression and retrieval of image and video content analysis possibilities. Other compression algorithms and standards have been developed and adopted in the last two decades for image/video storage, retrieval and transmission [5,9]. Visual content analysis and content-based image and video indexing and retrieval research have also achieved significant progress and generated many algorithms and system prototypes.

Although advances in digital imaging, satellite communications and the availability of ISDN lines have extended the reach of telemedicine applications in the developed countries, telemedicine applications still remain impractical and uneconomic in most rural and developing nations. Medical diagnosis and management could be achieved with the use of textual descriptions and still images [7] over fax, telephone or email but this does not provide sufficient information for correct diagnosis and prognosis by the experts during a telemedicine session.

With the availability of Internet connectivity and email services across most African countries and other developing nations of the world, existing infrastructures can be explored for our proposed application. The paper therefore focuses on the designed of a hybrid telemedicine application with hypermedia database features deployed securely over virtual private network. The remaining part of the paper is divided as follows:

Section 2 looks at Telemedicine Application Requirement, in section 3, we discuss Modeling the Hybrid Telemedicine Application, while in section 4, the Deployment of the proposed Telemedicine Application is discussed. We conclude in section 5 with a brief summary.

2. TELEMEDICINE APPLICATIONS REQUIREMENTS

The communications need of a multimedia system for telemedicine is largely dependent on the type of telemedicine being addressed. Types of telemedicine include: teleconsultating, telediagnosis and tele-education [2].

2.1 Teleconsultation: This involves the interactive sharing of images and other medical information in which the primary diagnosis is made by the doctor at the location of the patient. Generally, a teleconsultation is between a family practice expert located at a local medical center and the relevant specialist or subspecialties located in a remote medical center whose “second opinion” is sought to confirm a diagnosis by the local expert [2]. The patient(s) may not necessarily be present during teleconsultation. A list of clinical activities available in teleconsultation is well documented in literature [2, 6]. Video conferencing, including synchronized two-way audio and video is vital to support the verbal and nonverbal cues used in face-to-face conversation during teleconsultation.

2.2 Telediagnosis: This is a most prominent application of telemedicine and entails the sharing of images and medical information in which the primary diagnosis is made by an expert at a location remote from the patient [2]. The application required can be either synchronous or asynchronous. A synchronous telediagnosis has about the same video conferencing and document-sharing requirements as teleconsultation [2] but it takes higher communication bandwidth to accommodate the interactive image transfer and real-time high-quality diagnostic video. Asynchronous telediagnosis on the other hand is based on a “stored-and-

forward” architecture in which the multimedia components are assembled into a sort of “multimedia-email” and delivered to the expert for an offline diagnosis.

2.3 Tele-education: It involves the provision of education materials over a telecommunication network [2]. In telemedicine, it entails the dissemination of medical information, research and laboratory findings and results. It requires video conferencing with document image capabilities.

3. MODELLING THE HYBRID APPLICATION

Our proposed Hybrid Telemedicine Application (HTA), can allow effective and efficient use of medical resources available at medical centers to support the primary physicians. A camera having the capabilities to connect various medical instruments, e.g. Otoscope, ophthalmoscope, sigmoidoscope, and endoscope, is available to provide viewing of procedures performed by the remote site and facilitates consultations with the medical center. Physicians at both sites can view each other, discuss cases, have consultation with patient interview, and interact effectively to improve the quality of patient care through the Internet infrastructure. High-resolution patient camera with remote control capabilities which can be operated by either site is used. Real-time echocardiogram can also be transmitted via Virtual Private Network (VPN).

HTA has a call center using IP-based Customer Relationship Management (CRM) which connects patients by telephone, 24hrs/day and 365 days/year to the health information they seek. When a patient in need of medical services dials into the system she will have access to front desk information or an option of being connected to a medical specialist. If the caller (patient) selects a nurse for example, the nurse works through the patient’s symptoms and recommends appropriate course of action. The function of the nurse is usurped by the system [8]. HTA handles the functionalities of a typical telemedicine application but extended with an Automated Speech-Controlled Customer Care Service (ASR CCS) proposed in [8] to minimize Human-to-Human (H2H) interaction being replaced with Human-to-System (H2S) model to reduce response time, cost and possibilities of conflicts/misunderstanding that might emanate in the course of patient complaint-lodging and resolution in a H2H model.

The self starting capabilities of HTA enables it to initiate dialogue with patients by mailing diagnosis and therapies through a text message (or via email) to patients who had earlier made complaints and could not have a consultation session with a specialist via conferencing in a real-time mode.

A medical specialist function can be assisted by Service Provider’s Diagnostic Experts (SPDE) [8]. The system is able to store the patient’s recent call history and her doctor’s coverage information in its ASR CCS Database unit which is made up of several datasets and the Service Provider’s Diagnostic Expert (SPDE) unit. The SPDE unit helps to suggest therapies to a specialist based on previous interaction with patients using medical algorithms[10] based on knowledge-base techniques and data mining principles. This acts as a guide for appropriate management of any situation at hand. In instances where a doctor’s visit becomes necessary, the system books an appointment with the specialist in a participating healthcare center and reports to the patient when she can see the physician while automatically transferring the patient’s call record to the contacted specialist’s attention.

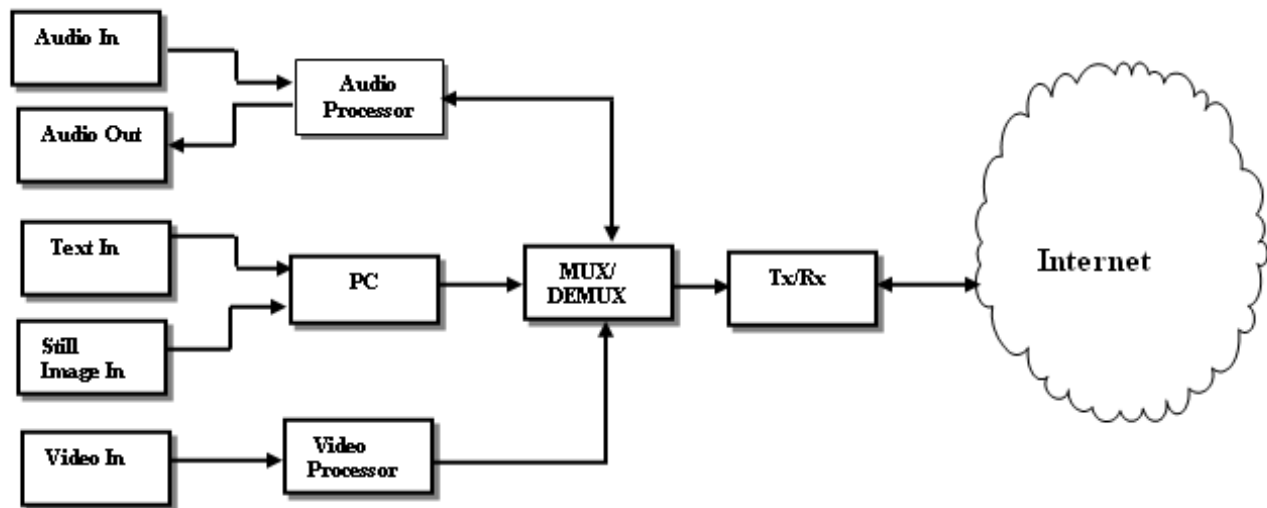

Fig. 1 Block diagram of HTA

MUX – Multiplexor
 DEMUX – Demultiplexor
 Tx-Transmitter
 Rx-Receiver

The HTA we propose as depicted in Fig. 1 is capable of transmitting text, images, video and speech information. This suggest that it will incorporate a Computer-Supported Cooperative Working System (CSCW) for text and image as well as videotelephony system (VT) for speech and video.

4. HYBRID TELEMEDICINE APPLICATION DEPLOYMENT CONSIDERATION

Telemedicine applications can be deployed over physical, hard-wired infrastructure of buildings, LANS, and public switched telephone network, fixed Internet and mobile wireless LAN infrastructure [11]. Wireless applications though faced with the challenges of device constraints, mobility, security and human behavior can be implemented with solutions such as Wireless Application Protocol (WAP), Java 2 Micro Edition (J2ME), I-mode and Binary Runtime Environment for Wireless (BREW) currently available for developing mobile applications. See table1 for the list of useful considerations.

CONCLUSION

This paper has described the design and deployment of a proposed Hybrid Telemedicine Application. The HTA is a robust system that harness the features of real-time and stored-and-forward Telemedicine applications by employing the real-time features of video conferencing and the near real-time (stored-and-forward) capabilities of hypermedia database over a network (Internet)

The HTA proposed in this paper will go a long way in reducing cost-implication of deploying Telemedicine applications in least developed countries (LDCs) and developing nations of the world, where it is hitherto almost non-existent.

Table 1: Telemedicine Application System Deployment Consideration

S/N	CONSIDERATION	EXAMPLES
1	Media	Copper Telephone lines, Fiber Optics lines, Satellite, Microwave, Radio, Co-axial cable
2	Telecommunication Services	Switched 56K, ISDN, ATM, T1, DS-3 or T4
3	Peripheral/medical	Endoscope, Otoscope, Microscope, X-RAY Scanner, Document Scanner, Ophthalmoscope, Dermoscope, Remote Monitoring Equipment
4	Video Conferencing	Studio Videoconferencing, Desktop Videoconferencing, Full-Motion Uncompressed, Video Analog Transmission, Digital Transmission
5	Data/Image Transfer System	Full-Motion interactive video, video 'clips', with 2-way audio, email, Internet chat
6	Camera	1-chip CCD camera, 3-chip CCD camera, Analog Video camera, Digitizing still Image Camera, Document camera, Macro Lens Camera with Peripheral Scope
7	Wireless device to deploy application	Cell phone, Smart card, Embedded processor, Personal digital assistant
8	Target Operating System	BREW, J2ME, Linux, .NET compact framework, Nokia's series, Smart phone, Symbian /EPOC, Windows CE and PalmOS
9	Connecting back-end to Wireless application	Messaging CGI, ODBC, JDBC, JCA
10	Application software for mobile telemedicine	Apache/Tomcat, ASP.Net, ColdFusion, HP Application Server, IBM WebSphere Everyplace, JRUN, Microsoft IIS, Oracle, iAPP Server Wireless Edition, WAP servers, Sun Java System Application Server and Borland Enterprise Edition
11	Security mechanism to be adopted	Public Key Infrastructure (PKI), Wireless PKI (WPKI), Biometrics, Digital Signature, Virtual Private Network (VPN) 2.0 Security
12	Security method to incorporate with wireless LAN (WAN)	Extensible authentication protocol, Wi-Fi, protected access, Wired Equivalent Privacy (WEP), Wireless Transport Layer Security(WTLS), Secure Sockets Layer (SSL)
13	IDE for the wireless development	Adobe, Borland C++, Borland Jbuilder, Borland Kylix, Borland C# Builder, Eclipses, IBM web sphere, Macromedia Dreamweaker MX, Microsoft Visual Studio, Nokia's SDK, OPEN tools, Oracle JDeveloper and Sun Java Studio

REFERENCES

- [1] James E. Cbral Jr. and Youngmin Kin, Multimedia Systems for Telemedicine and Their Communication Requirements, Image Computing System Laboratory, University of Washington, IEEE communication Magazine, July, 1996.

- [2] Zach S., Telemedicine Overview and Summary Ministry of Communications, Tel-Aviv, Israel, IEEE, 1996.
- [3] Roy R., Interactive Media, Springer-Verlag, 1995.
- [4] Where are the “Killer-Apps” for video content analysis and retrieval technologies, HongJiang Zhang, HP Labs (Panel Statement of Purpose): VLBV 98 Panel 4: Applications : University of Illinois at Champaign/Urbana, Oct 8-9, 1998.
- [5] Chandran and Abishek Ranjan, Combining Spanning trees and normalized cuts for Internet retrieval, Computer Science Department, Indian Institute of Technology, Bombay & Center for Automation Research, University of Maryland.
- [6] David L. Paul, Keri E. Pearlson and Reuben R. McDaniel, Jr, Assessing Technological Barriers to Telemedicine: Technology-Management Implications, IEEE Transaction on Management, 1999.
- [7] Hamish S. F. Fraser, Darius J, Peter Szolovits, Libby Levinson
TeleMedMail: Software to Facilitate Store and Forward Telemedicine in Developing Countries, MIT Laboratory for Computer Science, March 2003.
- [8] Atayero, A.A., Olugbara, O.O, Ayo, C.K., Ikhu-Omoregbe, N.A. Design, Development, and Deployment of an Automated Speech-Controlled Customer Care Service System, Proceedings GSPx 2004 - "The International Embedded Solutions Event" Santa Clara, CA, September 27-30, 2004.
- [9] Health, Telehealth (A Review of Contact North's "Emerging Technologies" Contact North's 2003, Emerging Technologies Conference, Valhalla Inn, Thunder Bay February 25-27, 2003.
- [10] Another Kind of Tele-Home: Medical Care Centers: Telemedicine Today:
<http://www2.telemedcinetoday.com/articles/anothertelehome.shtml>
- [11] Kugean C., Krishnam S.M., Chutatape O, Swaminathan S., Srinivasan N. and Wang P., Design of a Mobile Telemedicine System with Wireless LAN
IEEE, 2002.