

See discussions, stats, and author profiles for this publication at: <https://www.researchgate.net/publication/329964168>

# Two-Dimensional Computational Fluid Dynamics Simulation of A Gas-Fired Pyrolysis Furnace

Article in *International Journal of Civil Engineering and Technology* · December 2018

CITATIONS

0

READS

88

6 authors, including:



**Felix Ishola**

Covenant University Ota Ogun State, Nigeria

22 PUBLICATIONS 10 CITATIONS

[SEE PROFILE](#)



**Iyanuoluwa Ogunrinola**

Covenant University Ota Ogun State, Nigeria

5 PUBLICATIONS 1 CITATION

[SEE PROFILE](#)



**Patrick Onwordi**

Covenant University Ota Ogun State, Nigeria

4 PUBLICATIONS 0 CITATIONS

[SEE PROFILE](#)



**Opemipo Atiba**

Covenant University Ota Ogun State, Nigeria

14 PUBLICATIONS 14 CITATIONS

[SEE PROFILE](#)

Some of the authors of this publication are also working on these related projects:



Modelling and Simulation [View project](#)



uv rad [View project](#)



---

## 2-DIMENSIONAL CFD SIMULATION OF A GAS-FIRED PYROLYSIS FURNACE

**Felix A. Ishola, Patrick N. Onwardi, Opemipo E. Atiba, Blessed E. Adudu**

Mechanical Engineering Department, Covenant University, Ota, Nigeria,  
Ota, Nigeria

**Iyanuoluwa E. Ogunrinola, Amanda O. Ndubuisi**

Applied Physics Department, Covenant University, Ota, Nigeria

### ABSTRACT

*With the aid of a Computers programme application, Computer Systems can be used to mimic the interactions of fluids with solid surfaces, characterized by the experimental working conditions usually referred to as boundary conditions. In this article, the authors exhibited a steady state, atwo-dimensional Computational Flow Dynamics (CFD) model for a gas-fired pyrolytic furnace verified by distinctive numerical models. Solidworks was used to create the physical design of the pyrolytic Furnace as well as the CFD numerical simulation. The resulting analysis displayed the heat distribution at different regions of the furnace such to improve the understanding of the relationships between the combustion chamber of the furnace and the pyrolysis Capsule installed inside the furnace. The CFD also simulates the interaction of the precursor with the Nitrogen enabling environment of the vacuum pyrolysis chamber and also predict resultant temperature. All these are to assist in the design of a process control philosophy deployable for the control of the pyrolysis process taking into consideration that the control of the process determines the type and quality of the pyrolysis products. The result was discussed in correlation with the real experimental data and CFD was discovered to have given some specific guides towards having an optimized pyrolysis process.*

**Key words:** Pyrolysis, Gas-Fired Furnace, CFD and Design parameters.

**Cite this Article:** Felix A. Ishola, Iyanuoluwa E. Ogunrinola, Patrick N. Onwardi, Amanda O. Ndubuisi, Opemipo E. Atiba and Blessed E. Adudu, 2-Dimensional CFD Simulation of A Gas-Fired Pyrolysis Furnace, International Journal of Mechanical Engineering and Technology, 9(12), 2018, pp. 383–394.

<http://www.iaeme.com/ijmet/issues.asp?JType=IJMET&VType=9&IType=12>

---

## 1. INTRODUCTION

### 1.1. General

Pyrolysis is the thermal decomposition of precursor materials at elevated temperatures in the absence of air [1]. Pyrolysis is irreversible and it is an effective waste treatment method. The solid products of pyrolysis: Carbon black and Graphite have important Engineering applications [2]. A furnace confines temperature from a heat source and allows for a build-up of temperature for heat exchange environment for a material intended to be subjected to a high temperature at a regulated rate [3]. The quality of the furnace depends on how well evenly the incubated temperature is distributed and controllable [4]. Pyrolysis can either be fast or slow; fast pyrolysis when the furnace rapidly raises the temperature to a predestined temperature and slow pyrolysis when the temperature gain is over a very long period of time both produce different types of material [5],[6],[7]. A field of fluid mechanics that utilizes numerical techniques and algorithms to investigate and resolve issues that involve flows of fluid is known as Computational Flow Dynamics (CFD). The pyrolysis furnace investigated in this article is pilot scaled with the aim of developing it till an optimized design highly effective process is achieved, CFD simulations being a guide towards this [8]. The Authors had been carrying out a lot of experiments process. Some of the precursors that have been experimented with this furnace involve some agricultural wastes such as coconut shell, palm kernel shell; inorganic waste materials such as plastics and waste tyres [9].

### 1.2. The Furnace Description

The basic furnace outline has an auxiliary measurement being cubic of 0.8m by 0.8m as shown in Figure 1. The Furnace has a rectangular chamber of 0.3m by 0.3m square opening cutting through the length of the furnace (i.e. 0.8m) and surrounded by the refractory bricks this is referred to as the combustion chamber; this is where the heat generation and expedition takes place. At the center of the cubic space lies a barrel-shaped chamber which is shut at the two ends referred to as anaerobic chamber or pyrolysis chamber[10]. The pyrolysis chamber is 1.2m long and 0.17m wide with a pipe 3mm thickness of high carbon steel[11]. Two burners were put at two along the length of the chamber. With the end goal to limit the measure of heat loss, thus ensuring optimum efficiency, thermal resistive bricks of Kaolin were formed to about 12.5cm thick around the combustion chamber[12]. There are diverse types of Furnace dependent on the sort of fuel they utilize namely: Natural gas, Electricity and liquid fuel, focusing on the expected means of achieving a temperature required for pyrolysis process, considerations regarding the type of fuel to be used is imperative[13]. Summers (1999) demonstrated that Gas source is the most proficient given there is sufficient air supply for Complete combustion. The gas fire is generally clean, affordable, accessible, and effective choice[14]. The Furnace is intended to be controlled by the burning of the combustible methane gas because of the availability and econometrics of the methane gas. The ignition at the gas inlet points as the sources of the heat flux transition and after that the heat transfer happens in the whole of the Furnace with movements from the point of heat concentration to the less region until an equilibrium state is reached provided the heat confinement is effective[15]. The thick layers of refractory blocks form around the combustion chamber is to avoid heat loss into the Environment along these lines influences the heat to be held and built up inside the Furnace[16].

### 1.3. Principles of Operation in the Furnace

The principles of operation for the pyrolysis furnace are basically Conduction, Convection and Radiation relating together at a level of complex interactions.

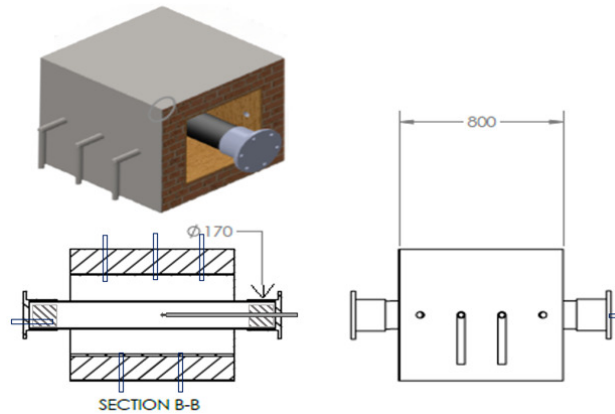

**Figure 1** Technical drawing of the model Pyrolysis Furnace[10]

### 1.3.1. Conduction

Energy is transfer in molecules due to energy gradient from more energetic to the less energetic region. Conduction occurs in solids, fluids and gases and the empirical relation governing the phenomenon is Fourier's law and partly Navier Stokes Equation to inculcate momentum and continuity of conduction [8]. Conduction occurs vertically along the pipe's (Pyrolysis Chamber) length, exchange of energy from high temperature area to the low temperature [17].

### 1.3.2. Convection

Energy transfer in fluid or gas due to the macroscopic motion. Convection can be described as a combination of Advection and Conduction. It is being governed by an empirical relation known as Newton's law of cooling. Convection takes place when fluid molecules through a physically solid body or through a channel due to temperatures differences between the fluidical phase and the surface of the body[18].

### 1.3.3. Thermal Radiation

Energy emission by a matter as a result of changes in configurations of electrons thus changes in energy via photons or EM waves. The governing relation is Stefan-Boltzmann law. Radiation occurs without any medium [19]. This heat transfer mode is prominent in the Pyrolysis Chamber as the flame produced in the combustion chamber is being emitted into the container where precursors stay by means of radiation [20].

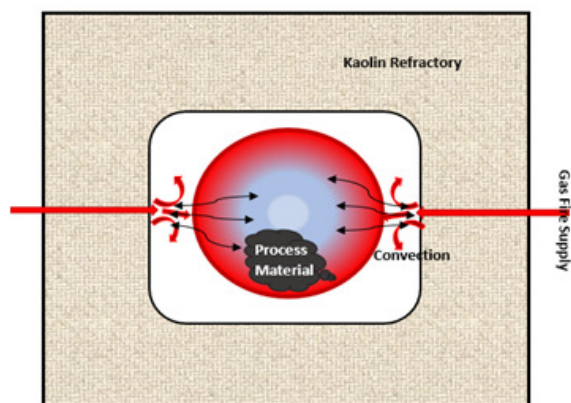

**Figure 2** Sectional View showing the concept of the model Pyrolysis Furnace[10]

#### 1.4. The model Furnace Optimisation Focus

The heat source is by the introduction of about 40mbar pressure of natural gas-oxygen mixture through two small nozzles one each from two sides. The Natural/Oxygen mix is regulated to eliminate smoky flames. The maximum temperature recorded at the combustion chamber is 1,200°C whereby the maximum operational temperature experienced within the pyrolysis chamber is about 500°C. A higher temperature as much as 1,200°C is desirable within the Pyrolysis Chamber to give us an optimum Carbon product. Also, a non-uniform Temperature distribution is noticed within the furnace. This is not desirable as it may lead to a different range of product quality within the chamber region. Presently, the furnace performs well with slow pyrolysis but a much better control of the temperature rise is much needed for fast pyrolysis which required high temperature within a limited period of time (shown in Figure 3). CFD had been found very useful in simulating heat generation, spread and distribution among other thermodynamic behaviours in modern heat Engines. The CFD simulation will help predict the needed parameters for an optimum furnace performance [21]. This will go a long way to help modify and manage the furnace to precision with a minimal cost implication due to the elimination of trial and error.

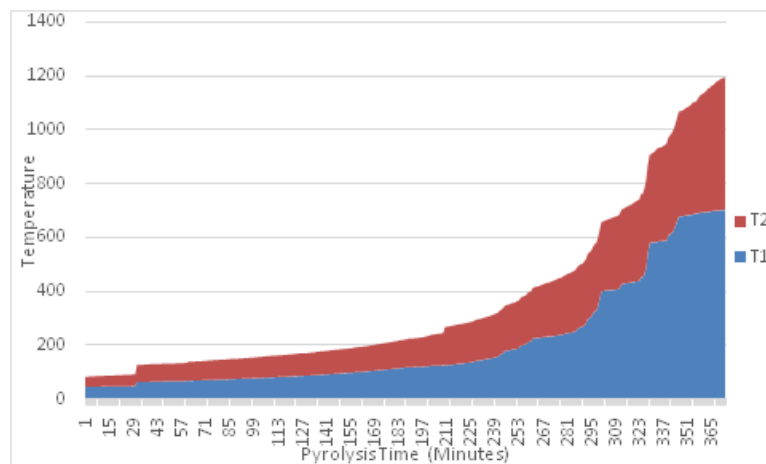

**Figure 3** Graph Showing the Combustion Chamber Temperature (T2) against Pyrolysis Chamber Temperature (T1) in a Pyrolysis run over a period of Pyrolysis Time (t)

## 2. COMPUTATIONAL MODEL

Generally, for gas furnaces and furnaces using a combustible oil, furnaces undergo four interactive processes:

- Flow (of fuel)
- Combustion (of fuel and flames)
- Heat (Radiation, Convection, Conduction as result of Combustion)
- Mass Transfer; which may involve a lot of processes like absorption of the heat by the introduced precursor material as well as the deflection or absorption of the refractories.

Heat transfer in furnaces cannot be achieved unless all these interactive processes are contacted. Each of these processes is executed using four (4) groups of equations. Corresponding with each other and solved simultaneously. It should be noted that the complete execution of this theoretical analysis is complex and so most likely not to be exact as lots of assumptions will be defined to represent the conditions [22]. Some basic assumptions include;

- Uniform Surface Temperature
- Isothermal Medium
- Uniform thermal conductivity
- Homogeneous material
- Temperature as a function of 1-D i.e 'Tx', if heat transfer is taking place in 'x' direction.
- No internal heat is generated
- Absolute heat energy is conservation

Generally, Heat,

$$Q = k\Delta tA \quad (1)$$

where  $k$  is the intensity of Heat Transfer Process

But Heat from a combusting gas to the furnace combustion chamber per kg of fuel is given as

$$Q_c = \frac{k\Delta tA}{B_{cal}} \quad (2)$$

where  $B_{cal}$  = Burnt Fuel

Convection heating Surface for a unit surface

$$q_c = \frac{Q_c}{A} = k\Delta t \quad (3)$$

### 2.1. Heat Transfer Co-efficient (k)

$K$  can also be defined as Heat Transfer per square meter of a heating surface where there exists a unit increase in temperature i.e 1oC. the larger the Heat Transfer Co-efficient the stronger the heat transfer process [23].Heat Transfer process of the built pyrolysis furnace is taken to be a combination of three (3) separate processes:

- Heat release from the combusting gas to the combustion chamber.
- Heat Conduction through the cylinder wall (both from the outer surface to the inner surface and along the length of the barrel).
- Heat release from the inner tube surface to the precursor load.

In actuality, the process is in form of a general serial heat transfer method by which the heat released from the combusting gas (LPG and Oxygen mixture) outlet to the combustion chamber of the furnace and then engulf the outer surface of the pyrolysis chamber. This serial Heat transfer mainly involves convection and radiation. In the same vein, the heat transfer from the outer surface of the cylinder to the inner surface is a pure conduction process and finally the heat transfer from the inner surface of the cylinder to the precursor would have been a pure convection process but not without the conduction process due to the fact that the precursor is having a contact with the surface of the cylinder [20].

### 2.1. Temperature Distribution within the Combustion Chamber

The efficiency of a furnace is mainly determined by its ability to reduce the loss of heat to the barest minimum; considering that the quantified loss is taken as the heat escaping from the body surface of the furnace into its immediate environment by natural means of convection and radiation [24].All the considerations, adoptions and assumptions of the design were defined accordingly. The expected temperature distribution of any thermal system, in this case, the pyrolysis furnace, is to be determined from the energy balance equation. e "*The rate*

of heat conduction at all sides + rate of heat generation inside = rate of change of the energy content.” Given the general heat flow equation using the one-dimensional steady heat conduction.

$$\frac{\partial^2 T}{\partial x^2} + \frac{\dot{q}}{K} = 0 \quad (4)$$

### 2.1.1. Thermal Resistance

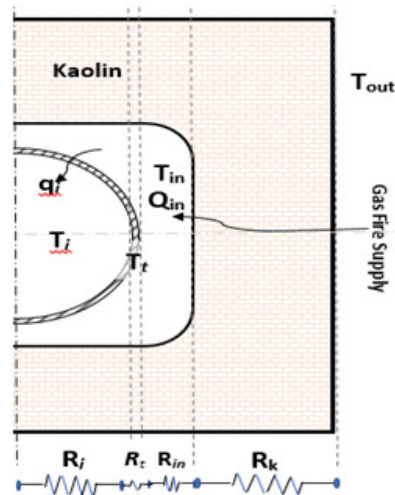

Figure 4 Schematic representation of the Pyrolysis Furnace[10].

Given Heat Origin,  $Q_{in}$  from the combustion gas, in the radial direction, the thermal resistance from the innermost part of the furnace to the outermost part which is the kaolin layer is represented by:

$$R_{total} = R_i + R_t + R_{in} + R_k \quad (5)$$

Where  $R_{total}$  is the total thermal resistance of the whole system in series,  $R_i$  is the thermal resistance to radiation inside the cylinder,  $R_t$  is thermal resistance to conduction through the shell of the cylinder,  $R_{in}$  is the thermal resistance to radiation and convection just outside the shell of the cylinder and  $R_k$  is the thermal resistance to conduction in the kaolin refractory[25]. The setup involves three different media on the radial direction which is the innermost part of the furnace (pyrolysis chamber), the region for heat transfer by radiation into the cylinder shell where the heat transfer is mainly by conduction along its length from the area of high heat concentration towards terminal ends having flanges[26]. The outside surroundings of the cylinder are where the exposure to the main heat source i.e the combustion arena. Given average Flame Temperature  $T_g$  which gives the “Rate of Heat Transfer”.

Heat transfer in this region is by radiation as well as. Therefore, the equation becomes;

$$R_{total} = R_{rad} + R_{cyl,cond} + R_{rad,conv} + R_{rect,cond} \quad (6)$$

$$= \frac{1}{\varepsilon_1 \sigma A_1} + \frac{\ln(r_2/r_1)}{2\pi L K_1} + \left( \frac{1}{\varepsilon_2 \sigma A_2} + \frac{1}{h_1 A_2} \right) + \frac{1}{K_2 A_3} \quad (7)$$

$\varepsilon_1$  is the emissivity of the gas used in the furnace,  $\sigma$  is the Stefan-Boltzmann constant,  $A_1$  is the area of the part of the cylinder,  $r_2$  is the outer radius of the cylinder,  $r_1$  is the inner radius of the cylinder,  $L$  is the length of the cylinder,  $\varepsilon_2$  is the emissivity of air just outside the cylinder,  $A_2$  is the area of free air just outside of the cylinder,  $h_1$  is the convection constant of air,  $K_2$  is the thermal conductivity of the kaolin thermal insulator,  $A_3$  is the area occupied by the kaolin thermal insulator[27].

### 2.2. Temperature Distribution within the Pyrolysis Chamber

Given the general heat flow equation

$$K \frac{\partial^2 f(x,t)}{\partial x^2} = \frac{\partial f(x,t)}{\partial t} \tag{8}$$

for  $0 \leq x \leq 1$  and  $t \geq 0$  where

$$f(0, t) = 1$$

$$f(x, 0) = 1 + x \text{ and}$$

$$\frac{\partial f(x,t)}{\partial x} = 0, \text{ at } x = 1$$

Where  $x$  is chosen to be 0.2 and  $t = 0.02$ . These values have been chosen to be the mesh size. If the diffusion constant is included, the numerical form of the equation can be written as:

$$[k\rho C_p] \frac{t}{x^2} (f_{i-1,j} + f_{i+1,j}) - [k\rho C_p] 2f_{i,j} + f_{i,j} = f_{i,j+1} \tag{9}$$

Where  $\frac{K}{\rho C_p}$  is the thermal diffusivity  $k$ , and  $k\rho C_p$  is the thermal conductivity  $K$ ?

$$[K] \frac{t}{x^2} (f_{i-1,j} + f_{i+1,j}) - [K] 2f_{i,j} + f_{i,j} = f_{i,j+1} \tag{10}$$



**Figure 5:** A hollow cylinder with length  $L$ , the internal and external radius of  $r_1$  and  $r_2$  respectively.

For a hollow cylinder as shown in figure 3, the equation for temperature distribution within its shell by conduction for the radial direction is:

$$[K_{cyl, cond}] \frac{t}{(r_2-r_1)^2} (f_{i-1,j} + f_{i+1,j}) - [K_{cyl, cond}] 2f_{i,j} + f_{i,j} = f_{i,j+1} \tag{11}$$

And that for the  $L$  direction is:

$$[K_{cyl, cond}] \frac{t}{L^2} (f_{i,j-1} + f_{i,j+1}) - [K_{cyl, cond}] 2f_{i,j} + f_{i,j} = f_{i,j+1} \tag{12}$$

Where  $K_{cyl, cond} = \frac{\ln(r_2/r_1)}{2\pi LR}$ ,  $R$  is the thermal resistance,  $r$  is the radius of the cylinder,  $r_1$  and  $r_2$  are the internal and outer radius of the cylinder assuming the cylinder is hollow and  $L$  the length of the cylinder[10].

For the cylinder, the equation for temperature distribution by radiation inside it for the radial direction is:

$$[\varepsilon\sigma] \frac{t}{r_1^2} (f_{i-1,j} + f_{i+1,j}) - [\varepsilon\sigma] 2f_{i,j} + f_{i,j} = f_{i,j+1} \tag{13}$$

And that for the  $L$  direction is:

$$[\varepsilon\sigma] \frac{t}{L^2} (f_{i,j-1} + f_{i,j+1}) - [\varepsilon\sigma] 2f_{i,j} + f_{i,j} = f_{i,j+1} \tag{14}$$

Where  $\varepsilon$  is the emissivity and  $\sigma$  is Stephan's constant[17].





Figure 6 Test- Running the model Pyrolysis furnace[11].

### 3. CFD SIMULATION ANALYSIS

#### 3.1. Analysis Environment

SoftwareProduct: FlowSimulation 2016 SP1.0. Build: 3296  
CPUType: Intel(R) Core(TM) i3-4130 CPU @ 3.40GHz  
CPUSpeed: 3400MHz  
RAM: 8009MB / 134217727 MB  
OperatingSystem: (Build 9600)

#### 3.2. Model Information

ModelName: Assembly.SLDASM  
ProjectName: Heat Flux within a Furnace

#### 3.3. Project Comments: To determine the effect & temperature change within a furnace

UnitSystem: SI (m-kg-s)  
AnalysisType: Internal

#### 3.4. Simulation Parameters

##### Mesh Settings

Table 1 Showing the Basic Mesh Dimensions

Number of cells in X	8
Number of cells in Y	10
Number of cells in Z	30

### 3.5. Analysis Mesh

Cell count: 50198  
 FluidCells: 28905  
 SolidCells: 21293  
 PartialCells: 13810  
 TrimmedCells: 0

### 3.6. Additional Physical Calculation Options

Heat-Transfer-Analysis: Heat conduction in solids: On  
 Heat conduction in solids only: Off  
 Flow-Type: Laminar and turbulent  
 Time-Dependent Analysis: On  
 Gravity: Off  
 Radiation: On  
 Humidity: Off  
 Default Wall Roughness: 0 micrometre

### 3.7. Material Settings

Table 2 Showing the Materials Selections

<p><b>Fluids</b>                  Nitrogen                  Air</p>	<p><b>Solids</b>                  Steel (Mild)                  Ceramic Porcelain</p>
---	---

### 3.8. Initial Conditions

Table 3 Showing the initial Parameters

Thermodynamic parameters	Static Pressure: 101325.00 Pa Temperature: 293.20 K
Velocity parameters	Velocity vector Velocity in X direction: 0 m/s Velocity in Y direction: 0 m/s Velocity in Z direction: 0 m/s
Solid parameters	Default material: Ceramic Porcelain Initial solid temperature: 293.20 K Radiation Transparency: Opaque
Concentrations	Substance fraction by mass Nitrogen 1.0000 Air 0
Turbulence parameters	

### 3.9. Boundary Conditions for first and second runs

Inlet Mass Flow

**Table 3a:** Three points of gas fire inlet

Type	Inlet Mass Flow
Faces	Face<3>@LID5-1 Face<2>@LID9-1 Face<4>@LID6-1
Coordinate system	Global coordinate system
Reference axis	X
Flow parameters	Flow vectors direction: Normal to face Mass flow rate: 0.0100 kg/s Fully developed flow: No Inlet profile: 0
Thermodynamic parameters	Approximate pressure: 101325.00 Pa Temperature: 1473.20 K
Turbulence parameters	Boundary layer parameters
Boundary layer type	Turbulent

**Table 3b:** Six points of gas fire inlet

Type	Inlet Mass Flow
Faces	Face<1>@LID5-1 Face<2>@LID9-1 Face<3>@LID8-1 Face<4>@LID7-1 Face<5>@LID3-1 Face<6>@LID6-1
Coordinate system	Global coordinate system
Reference axis	X
Flow parameters	Flow vectors direction: Normal to face Mass flow rate: 0.0100 kg/s Fully developed flow: No Inlet profile: 0
Thermodynamic parameters	Approximate pressure: 101325.00 Pa Temperature: 1473.20 K
Turbulence parameters	Boundary layer parameters
Boundary layer type	Turbulent

#### 4. RESULTS AND DISCUSSIONS

The hot combusting gas temperature distribution showing in two-dimensional plane indicating temperature inside the pyrolysis chamber to be 354.02°C for (a) and 690.83°C for (b) of Figure 7; this implies a tremendous 30.88% increase in the efficiency of the furnace.

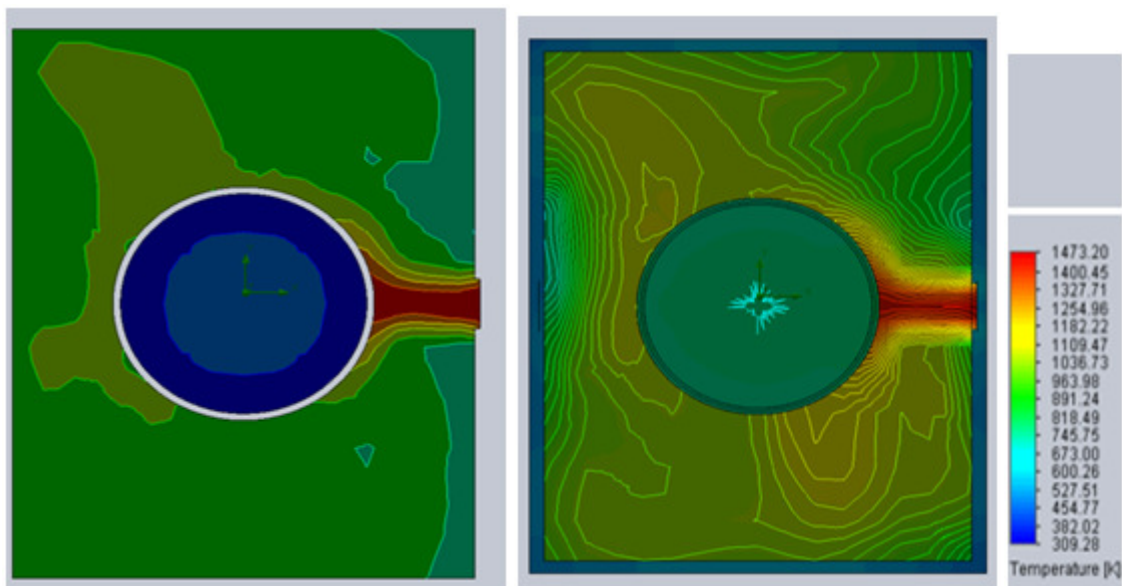

(a) Design for Three points of gas fire inlet      (b) Design for Six points of gas fire inlet

**Figure 7** Diagram showing a central gas fire inlet

The hot combusting gas temperature distribution showing in two-dimensional plane indicating temperature inside the combustion chamber to be an average of 554.66°C for (a) and 939.8°C for (b); with (b) showing a more evenly distributed temperature profile.

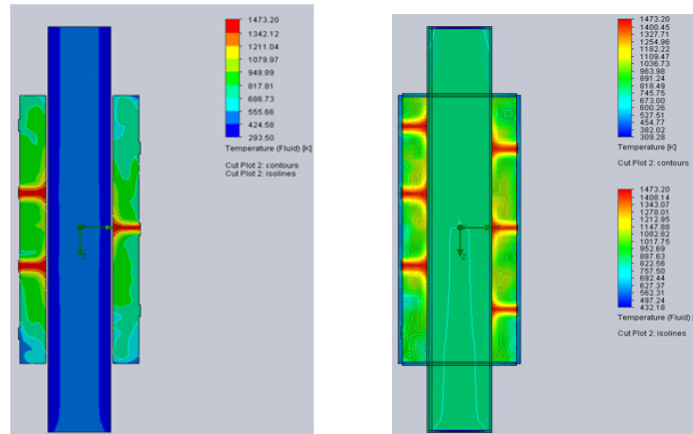

(a) Design for Three points of gas fire inlet (b) Design for Six points of gas fire inlet

**Figure 8** Diagram showing all the gas fire inlets

## 5. CONCLUSION

The 2D CFD simulation of the gas-fired pyrolysis furnace is successfully carried out using Solidworks Software. A germane factor in CFD is Meshing and 50,198 cells were involved; this is adequate to supply convergence of the solution. The simulations carried out shows an evenly distributed temperature profile as well as the improved efficiency by increasing the inlet for the gas fire from three to six spreads across the geometry of the Combustion Chamber. This will expressly address the issue of low-quality pyrolysis and give a more solid control over the pyrolysis process.

## ACKNOWLEDGMENT

We acknowledge Covenant University for funding this publication.

## REFERENCES

- [1] H. O. Pierson, Handbook of carbon, graphite, diamond and fullerenes: processing, properties and applications, Aufl. Park. New Mexico: Noyes Publications, 1993.
- [2] V. Chhabra, Y. Shastri, and S. Bhattacharya, "Kinetics of Pyrolysis of Mixed Municipal Solid Waste-A Review," *Procedia Environ. Sci.*, vol. 35, pp. 513–527, 2016.
- [3] A. Abioye, O. P. Abioye, O. O. Ajayi, S. A. Afolalu, M. A. Fajobi, and P. O. Atanda, "Mechanical and Microstructural Characterization of Ductile Iron Produced From Fuel-fire Rotary Furnace," *Int. J. Mech. Eng. Technol.*, vol. 9, no. 1, pp. 694–704, 2018.
- [4] S. K. Jawad, "Investigation of the Dimensions Design Components for the Rectangular Indirect Resistance Electrical Furnaces," *Am. J. Eng. Appl. Sci.*, vol. 3, no. 2, pp. 350–354, 2010.
- [5] A. Elfakhany, "Modeling of Secondary Reactions of Tar (SRT) Using a Functional Group Model," *Int. J. Mech. Eng. Technol.*, no. May, 2015.
- [6] Funke, A., Demus, T., Willms, T., Schenke, L., Echterhof, T., Niebel, A., Pfeifer, H. and Dahmen, N., "Application of fast pyrolysis char in an electric arc furnace," *Fuel Process. Technol.*, vol. 174, no. October 2017, pp. 61–68, 2018.
- [7] A. Cadena-Ramírez, A. Favela-Contreras, and G. Dieck-Assad, "Modeling and simulation of furnace pulse firing improvements using fuzzy control," *Simulation*, vol. 93, no. 6, pp. 477–487, 2017.

- [8] G. Dasari, A. Krishnaiah, and A. Gupta, "Model Reduction of CFD Simulation of Integrated Circuit Cooling of an Electronics Packaging," *Int. J. Mech. Eng. Technol.*, vol. 9, no. 3, pp. 806–812, 2018.
- [9] S. Sunphorka, B. Chalermssinsuwan, and P. Piumsomboon, "Application of artificial neural network for kinetic parameters prediction of biomass oxidation from biomass properties," *J. Energy Inst.*, 2015.
- [10] F. A. Ishola, A.K Aworinde, O.O Ajayi, F. A. Oyawale, and A. O. Inegbenebor, "Parameters for Design and Construction of a Pilot Scale Pyrolysis Gas-Furnace," in *Proceedings of the 2018 International Conference on Industrial Engineering and Operations Management.*, 2018.
- [11] F. A. Ishola, F. A. Oyawale, A. O. Inegbenebor, and H. Boyo, "Design of a high Temperature 'Anaerobic Gas-Furnace' suitable for Pyrolysis," in *IOP Conference Series: Materials Science and Engineering*, 2018, vol. 413, p. 012079.
- [12] N. V. Pitak, R.M. Fedoruk, T.P. Khmelenko, R.S. Shulyak, V.K. Zima, I.P. Davydov, R.E. Shcherbina, and G.A. Belokry, "High-density kaolin Refractories," *Refractories*, vol. 19, no. 1–2, pp. 9–14, 1978.
- [13] P. O. Babalola, "Design and construction of tilting furnace for producing aluminium matrix composites," *Proc. ICCEM*, 260-271, pp. 260–271, 2012.
- [14] C. M. Summers, "The Conversion of Energy," in *Scientific American*, vol. 225, no. 3, 1999, pp. 148–160.
- [15] B. Z. Adewole, O. A. Abidakun, and A. A. Asere, "Artificial neural network prediction of exhaust emissions and flame temperature in LPG (liquefied petroleum gas) fueled low swirl burner," *Energy*, vol. 61, pp. 606–611, 2013.
- [16] A. M. Paramonov, "Heating furnaces efficiency improvement," *Procedia Eng.*, vol. 113, pp. 181–185, 2015.
- [17] R. W. Serth, *Process Heat Transfer Principles and Applications*. Elsevier Ltd, 2007.
- [18] D. Q. Kern, *Process Heat Transfer*, Internatio. McGraw-Hill International Book Company, 1983.
- [19] A. S. A. Abbas, "Effects of the Combustion Gases on The Radiation Heat Transfer," *Int. J. Mech. Eng. Technol.*, vol. 9, no. 8, pp. 230–247, 2018.
- [20] J. Vondál and J. Hájek, "Wall heat transfer in gas-fired furnaces: Effect of radiation modelling," *Appl. Comput. Mech.*, vol. 9, pp. 67–78, 2015.
- [21] A. R. Tajik, T. Shamim, R. K. A. Al-Rub, and M. Zaidani, "Two Dimensional CFD Simulations of a Flue-wall in the Anode Baking Furnace for Aluminum Production," *Energy Procedia*, vol. 105, pp. 5134–5139, 2017.
- [22] N. T. Mohite and R. G. Benni, "Optimization of Wall Thickness for Minimum Heat Losses for Induction Furnace," vol. 10, no. 1, pp. 453–461, 2017.
- [23] Myer Kutz, *Heat-Transfer Calculations*, vol. 53, no. 9. 2013.
- [24] Y. Kodera and M. Kaiho, "Model calculation of heat balance of wood pyrolysis," *Nihon Enerugi Gakkaishi/Journal Japan Inst. Energy*, vol. 95, no. 10, pp. 881–889, 2016.
- [25] A. A. Abioye, P. O. Atanda, O. F. Kolawole, and O. E. Olorunniwo, "The Thermal Analysis of Fuel Fired Crucible Furnace Using Autodesk Inventor Simulation Software," vol. 5, no. 3, pp. 1–7, 2015.
- [26] P. M. Desai, B. C. Pathak, V. A. Patel, and P. B. Rana, "Design, Analysis and Optimisation of Body Flange and Cover Flange Using Finite Element Analysis," *Int. J. Mech. Eng. Technol.*, vol. 4, no. 5, pp. 81–87, 2013.
- [27] A. Abioye, O. E. Olorunniwo, and L. Oluwole, "Material Selection for the Fuel Fired Crucible Furnace Using GRANTA," no. July, 2014.