

PAPER • OPEN ACCESS

## Development and construction of automatic three-phase power changeover control circuit with alarm

To cite this article: A Abdulkareem *et al* 2021 *IOP Conf. Ser.: Mater. Sci. Eng.* **1036** 012081

View the [article online](#) for updates and enhancements.



**240th ECS Meeting** ORLANDO, FL

Orange County Convention Center Oct 10-14, 2021



Abstract submission due: April 9

**SUBMIT NOW**

# Development and construction of automatic three-phase power changeover control circuit with alarm

A Abdulkareem<sup>1</sup>, T E Somefun\*<sup>1</sup>, V Oguntosin<sup>1</sup>, and F Ogunade<sup>2</sup>

<sup>1</sup>Department of Electrical and Information Engineering, Covenant University

<sup>2</sup>Department of Electrical and Electronics Engineering, University of Ibadan

\*Corresponding author's e-mail address: tobi.shomefun@covenantuniversity.edu.ng

**Abstract.** One primary reason for Nigeria economic underdevelopment is the inconsistency of power supply, and as a result of this fact, immediate attention is required. The criticality of an uninterrupted power supply cannot be overemphasised. Therefore, in this work, a new approach is applied to switch power from a three-phase source to another without human interference. This work presents an automatic three (3) phase power changeover circuit with an alarm that turns power supply from Power Holding Company of Nigeria (PHCN) to a power generator at an instant of interruption or outage from PHCN. The signal is introduced to notify the user of the restoration of the PHCN supply and automatically carries out this process. This process is achieved by using logic control circuits, three-phase sequence monitors, phase(s) failure monitor, overload relay, and contacting relays for practical switching which takes approximate 30 seconds.

## 1. Introduction

In most developing and underdeveloped parts of the world, for instance, in Nigeria, the supply of electricity from PHCN is unstable [1-4]. Thus, the use of alternative sources of power supply, such as microgrid, distributed generator(s), generators, etc. is highly required to meet the end-users energy requirement [3, 5-7]. [5, 6] [5, 6] Changeover control circuit that will aid the continuous supply of energy without interruption during the loop is needed. Several changeover circuits have been built, most of which are single-phase [8-15]. Since automation has found space in almost every field of endeavour [16], this work, therefore, deploys an automatic changeover circuit with an alarm for a three-phase system. The design incorporates proper monitoring measures to avoid equipment damage and ensure efficient delivery of services such as surgery, banking activities, etc. This design eliminates the element of human interaction involved in changing the power supply from one source to another. It also upholds an excellent service via its quick and rapid response. An automatic changeover switch with an alarm is an electrical device that uninterruptedly observes electrical power supply, notifies the user via the alert, and connects the load to a standby source of electric power if the utility goes off, provided safety measures have been adequately satisfied. This design accurately monitors the incoming supply from the PHCN grid supply before connecting it to the load; the voltage monitor, phase failure, and overload relay are used to carry out this process. If these safety conditions are not met, the load continues to run on auxiliary supply. Still, the buzzer alarm notifies the user on the availability of PHCN supply, indicating a fault. In contrast to the manual changeover switching system that requires manual procedure in starting the generator and switching over from PHCN supply to the generator supply and vice-versa, there is a need to develop an automated control system to manage electric power supply between two



Content from this work may be used under the terms of the [Creative Commons Attribution 3.0 licence](https://creativecommons.org/licenses/by/3.0/). Any further distribution of this work must maintain attribution to the author(s) and the title of the work, journal citation and DOI.

sources effectively. This automated system prevents damage to equipment, therefore, influences the motivation for this work [8].

**2. Research materials and methods**

For ease of understanding of the proposed circuit in this study, the three-phase block diagram is given in Figure 1. The proposed course is an application that ensures active switching between two different power sources; PHCN and a three-phase generator. The electrical component used is at the rate of 100% to ascertain a very reliable circuit that would function efficiently at the standard operating capacity. The three-phase automatic changeover circuit is designed with the following specification: 415 V line to line voltage and 50 Hz frequency. The total expected load for the circuit is 1,030 Watts, which comprises one 550 W three-phase induction motor, three pieces of 60 W electric bulbs, two pieces of 150 W electric standing fans.

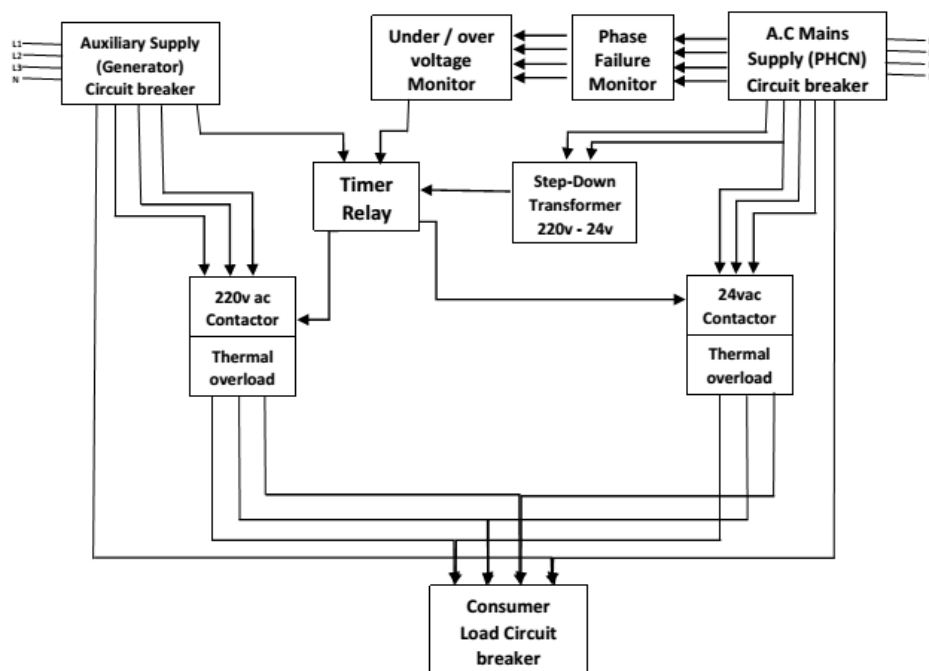

**Figure 1.** A detailed block diagram of a change over

The line current is obtained from the three-phase power equation as shown below:

$$P = \sqrt{3} V I \text{Cos}\theta \tag{1}$$

Therefore, line current  $I_L = \frac{P}{\sqrt{3} V \text{Cos}\theta}$

where Cos θ (power factor) is taken as 0.8 and approximate total power as 1,500 W

Therefore, substituting into equation (1) gives

$$I_L = \frac{1.5 \times 10^3}{\sqrt{3} \times 415 \times 0.8}$$

$$I_L = 2.61 \text{ A}$$

According to NEC 430-52 standard, the rating of the circuit breaker is dependent on the line current and is gotten from the formula [17];

Size of circuit breaker = 250% × Line current  
 = 2.5 × 2.61 = 6.53 A

Hence a breaker size of 10 A is suitable.

The contactors are sized based on the line current flowing through them.

For the main contactor;

$$\begin{aligned} \text{Rating} &= 100\% \times \text{Line current} \\ &= 1 \times 2.61 = 2.61 \text{ A} \end{aligned}$$

Figure 2 shows a complete circuitry design and construction of the automatic three-phase power supply changeover circuit. The connection network of each component is clearly shown.

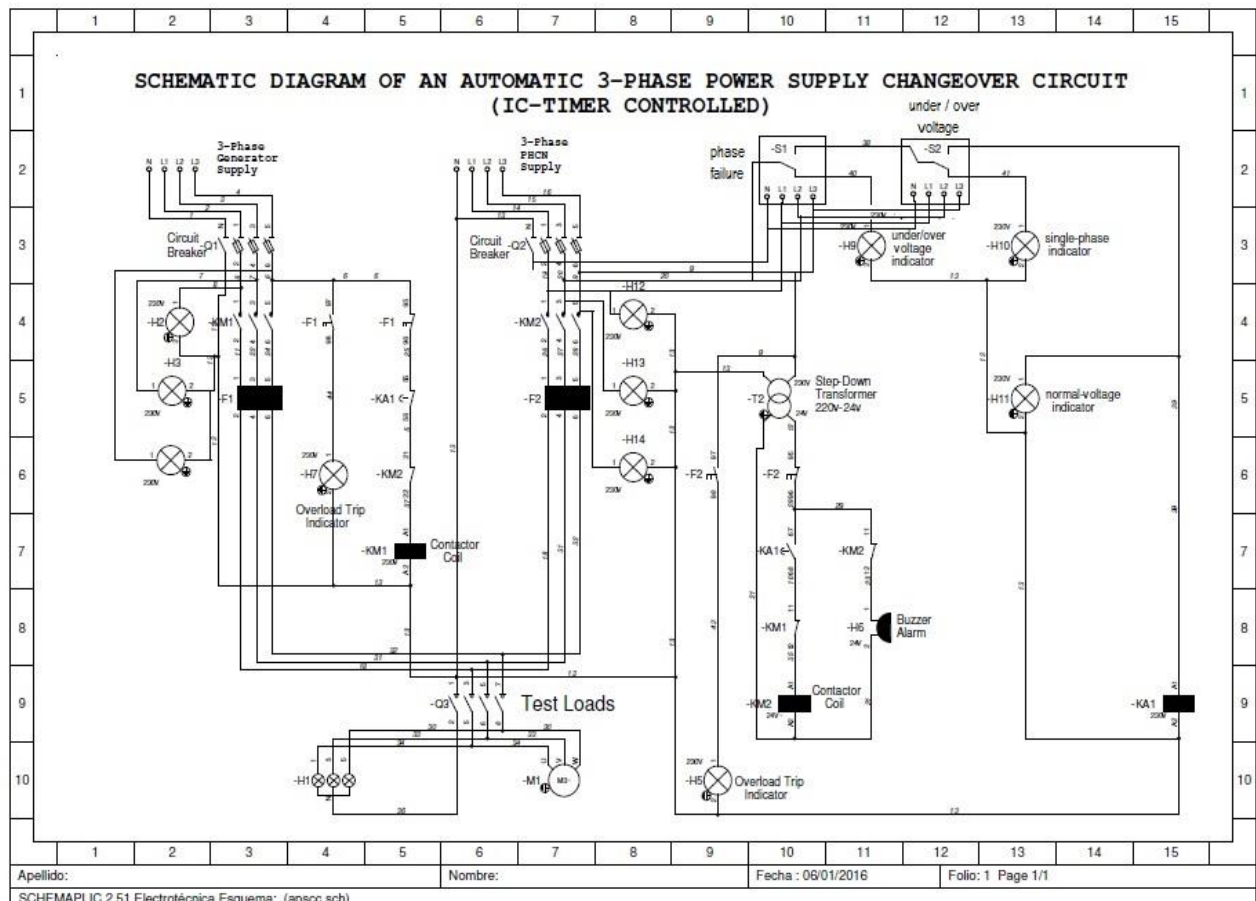

**Figure 2.** Complete circuit schematic diagram [18]

The automatic changeover operation is primarily to switch electric power from the main supply (PHCN) to the auxiliary supply (Generator) with prompt and effective timing sequence. The system comprises two different circuits, namely; the primary supply circuit and the auxiliary supply circuit. Basically, for the proper operation of the system, the auxiliary supply will be put to service first because the main power supply operates to break the operation of the generator while in the process through its ignition system.

The system automatically interconnects, (i.e. an interlock is created) using the time delay relay between the PHCN supply and Generator supply. The auxiliary supply circuit is controlled by the normally closed (N/C) contact of the timer and normally closed (N/O) contact of the mains supply circuit's energising contactor. While the primary supply circuit is controlled by the normally open (N/O) contact of both the timer and the energising contactor of the auxiliary supply, thus creating an interlocking between the two circuits.

By making the control connection of the ignition circuit in series to the control of the primary supply circuit on a normally closed contact, the ignition system of the auxiliary contact plays a vital role in designing the system. As a result, when the PHCN supply is available, the ignition system connection is broken from the mains supply contact, making the normally closed to be opened depending on the

time lag on the timer relay before switching. The timer is delayed to ensure the stability of the power from the PHCN. At the same time, a buzzer alarm is connected to the timer contact to notify the users of the availability of PHCN supply.

Three major factors determine the switching from one supply to another, viz; over and under voltage, timer relay and single phasing. These factors monitor the supply input from the PHCN based on the minimum and maximum required voltage. If by default, the voltage monitor is pre-set to 350 Vac minimum and 415 Vac maximum, supply inputs other than the pre-set will be detected by the voltage monitor. Single phasing fault is also monitored, thus preventing the system from switching. The issue of voltage fluctuation and phase failure is critically dealt with while using an industrial appliance such as a three-phase induction motor. Hence, provision of a manual switch is incorporated in the circuit for domestic use only. This is in any case of under voltage, or single-phase, user can manually switch, but possible only if the equipment or appliance to be used conforms to the input power condition. As projected as a three-phase operating system, this system still satisfies the requirements for single-phase appliances.

### 3. System implementation and results

The testing and implementation of the design are very critical in ensuring proper working operation. The circuit breaker make-and-break prompt operation was ascertained shorting two phases during supply. The contactor was supplied with 220Vac to its coil contacts A1 and A2. The magnetic coil experienced electromagnetic induction; thus, energising the contactor and supply of three-phase voltage made available to the overload terminals. The contactor breaking capacity was confirmed by manually actuating the overload relay, which causing the overload circuit break internally and change the state of its control terminals (i.e., Normally closed became normally open and vice versa). And there was an indication on the panel box via the indicator bulb, showing an auxiliary overload trip as display in Figure 3.

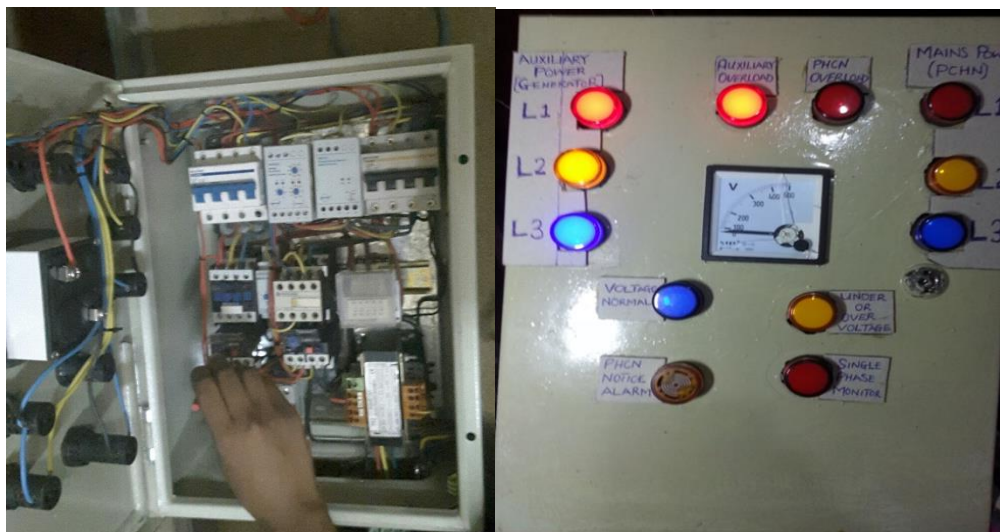

**Figure 3.** Thermal overload manually tripped and bulb indicating the tripping of the auxiliary overload

The components that make up the auxiliary unit (circuit breaker, contactor, overload) were tested separately to ensure reliability and proper functionality. After which they were all tested as a unit with test bulbs being attached. All the three bulbs came on, indicating a complete three-phase supply and adequate functioning of all components in the auxiliary unit as shown in Figure 4



**Figure 4.** All bulbs on, indicating complete Three-phase supply

Phase failure monitor operation was confirmed by disconnecting one out of the three-phase supply. It made the system unable to supply power as a result of a single-phase fault. The buzzer alarm sounded continually notifying the user of the availability of the PHCN supply, while the timer counted as pre-set. Hence, both under/over voltage and single-phase fault is indicated on the panel, as shown in Figure 5. Reason being that a single-phase fault automatically will affect the under-voltage monitor.

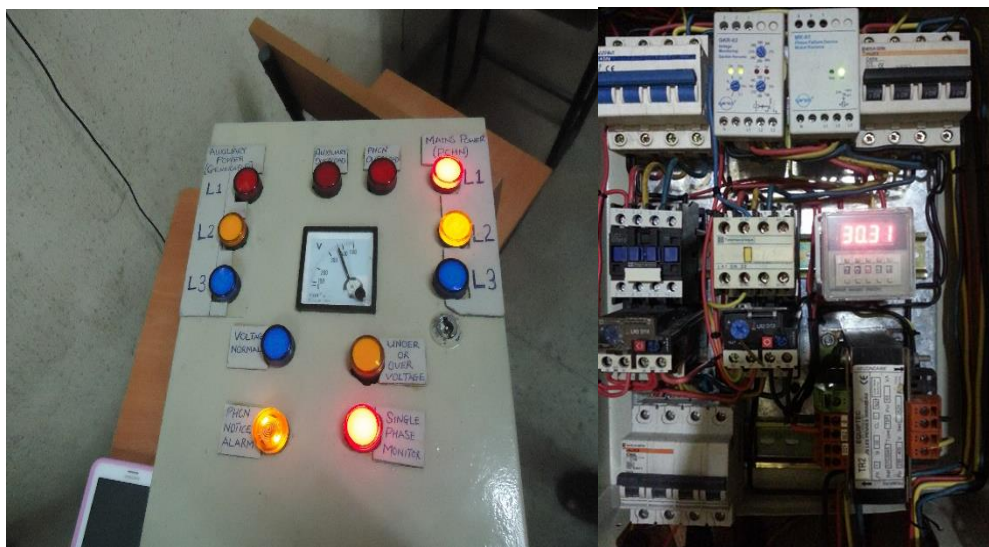

**Figure 5.** Single-phase fault

Testing for over and under voltages was technical like other tests. The process has to do with setting a timing preference to ensure how fast or slow the device needs to rectify any voltage imbalances (time lag of auto-switching of output upon voltage fluctuation). The input voltage per phase of the voltage monitor was measured with a multimeter and it indicated a reading of 179.6 Vac. The upper limit of the voltage monitor was set beyond the measured voltage (240 Vac), and the lower boundary was also set above (180 Vac), the measured voltage. Upon proper reconnection of the disconnected phase (Blue phase) used for the phase failure test. There was no longer an indication of a single-phase fault on the

panel. The voltage moves from the phase failure monitor to the under/over voltage monitor as input but not as output, due to the voltage monitoring device's abnormal voltage recognition. Here, the under-voltage indicator is turned ON on the device, as shown in Figure 6, which leaves the voltage signal received earlier from the phase failure not to cross as required voltage. When the device's adjustment knob was tuned below the measured voltage (175 Vac), the monitor switched to give output after 4 seconds, as shown in Figure 7. The monitoring devices indicate a high level of reliability and functionality at that point.

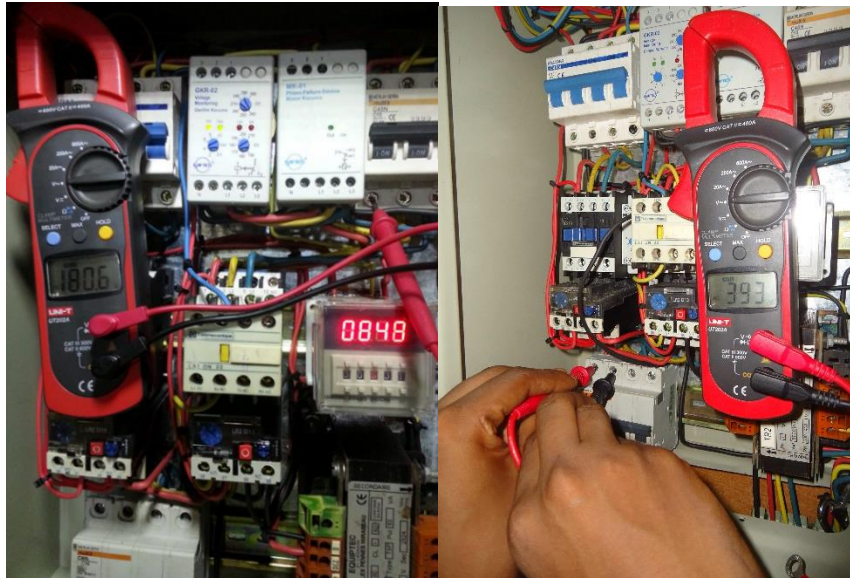

Figure 6. Voltage monitor showing an under-voltage input and indicator panel



Figure 7. Voltage monitor indicating normal voltage input after adjustment of the lower limit.

Upon certification that all the components on the main supply unit are working properly and reliable. The entire unit was tested as a unit with load(s) attached. Figure 8 shows the testing process:



**Figure 8.** Test load per phase and on three-phase

The result from the input voltage test is shown in Table 1.

**Table 1.** Input voltage for single-phase and three-phase

Single-phase	Voltage (Volt)	Three-phase	Voltage (Volt)
L1	180	L1-L2	395.1
L2	179.5	L2-L3	397.2
L3	182.4	L1-L3	396.3

Different reading on the phase from Table 1 indicates unbalanced load on the three-phase system. Since all phases are completely connected, both phase failure and under/over voltage monitor switched the output to the timer. In that way, the output of the series-connected phase failure and voltage monitor crosses to energise the timer relay. The energising voltage from the step-down transformer at a normally open N/O contact of the timer switched to the overload normally closed contact to energise the 24 Vac at 30.31 seconds. The 24 Vac Contactor allowing the three-phase supply gets to the load-end circuit breaker.

#### 4. Conclusion

An automatic three-phase power change over control circuit with alarm is developed and constructed in this work. The developed prototype of the automatic three-phase changeover switch worked perfectly and minimise damages to lives/equipment. It maintains a high quality of service through its quick and rapid response of 30 seconds for generator to come up. Human error that can lead to loss of life and or damage of equipment is guided against in the developed work of the automatic three-phase changeover because it is fully automated.

#### Acknowledgement

The authors would like to express special thanks and gratitude to Covenant University for her support.



## References

- [1] Ijewere, A. A. 2011. The Management of Electricity Power Supply in Nigeria: Problems and Prospects, *Journal of Research in National Development*, **9**, pp. 173-185
- [2] Oluwatoyin, K. K. Odunola A. M., and Alabi A, 2015. Ways of Achieving Stable and Uninterrupted Power Supply of Electricity in Nigeria," *Br. J. Appl. Sci. Technol.*, **10**, pp. 1-15
- [3] Somefun T. E., 2018. Critical review of different methods for siting and sizing distributed generators, *TELKOMNIKA (Telecommunication Computing Electronics and Control)*, **16**.
- [4] Babatunde O. M., Ayegbusi C. O., Babatunde D. E., Oluseyi P. O., and Somefun T. E, 2020. Electricity Supply in Nigeria: Cost Comparison between Grid Power Tariff and Fossil-Powered Generator," *International Journal of Energy Economics and Policy*, **10**, pp. 160-164
- [5] Kolo J. G, 2007. Design and construction of an automatic power changeover switch," *Assumption University Journal of Technology*, **11**, pp. 1-6,
- [6] Amoo O. M. and Fagbenle R. L., 2013. Renewable municipal solid waste pathways for energy generation and sustainable development in the Nigerian context, *International Journal of Energy and Environmental Engineering*, vol. **4**, p. 42,
- [7] Somefun T, Awosope C, Abdulkareem A, and Alayande A, 2020. Deployment of Power Network Structural Topology to Optimally Position distributed Generator within Distribution System," *Journal of Engineering Science and Technology Review*, vol. **13**, pp. 12-17.
- [8] Agbetuyi A, Adewale A, Ogunluyi J, and Ogunleye D, 2011. Design and construction of an automatic transfer switch for a single phase power generator, *International journal of engineering science*, vol. **3**, pp. 1-7.
- [9] Ahmed M, Mohammed A, and Agusiobo O, 2006. Development of a single phase automatic change-over switch, *Department of Electrical and Computer Engineering, Federal University of Technology Minna, Nigeria*,
- [10] Acakpovi A, Bennet M. M, and Akortia N, 2016. Design, testing and analysis of single phase electronic changeover with security light," *APT Journal of Multidisciplinary Research*, vol. **1**,
- [11] Shuttleworth R, 1997. Electrical changeover switching, ed: Google Patents.
- [12] Ehiabhili J, Ezeh C, and Orji O, 2018. Single Phase Microcontroller-Based Automatic Changeover Switch," *International Journal of Electronics, Communication & Instrumentation Engineering Research and Development (IJEICERD)*, vol. **8**, pp. 7-16.
- [13] Yang T.-H, 1987. Capacity-movement model AC inductive motor switch-changeover capacity-type speed control circuit, ed: Google Patents.
- [14] Samuel L, Cohen J. E, and Gumpertz B. E, 1957. Automatic changeover apparatus, ed: Google Patents.
- [15] Obasi C. C, Agidani O. B. O. J. J, Onyedikachi V, Ubadike I, and Osichinaka C, 2015. Design and Implementation of Microcontroller Based Programmable Power Changeover, *International Journal of Computer and Intelligent Systems*, vol. **6**, pp. 51-56.
- [16] Shomefun T. E., OA A. C, and Diagi E. O, 2018. Microcontroller-Based Vertical Farming Automation System," *International Journal of Electrical and Computer Engineering*, vol. **8**, p. 2046.
- [17] Hall W. M. and Gregory G. D, 1999. Short-circuit ratings and application guidelines for molded-case circuit breakers," *IEEE transactions on industry Applications*, **35**, pp. 135-143.
- [18] Covic G. A., Boys J. T, Kissin M. L, and Lu H. G. 2007. A three-phase inductive power transfer system for roadway-powered vehicles, *IEEE Transactions on Industrial Electronics*, vol. **54**, pp. 3370-3378.