

PAPER • OPEN ACCESS

Effect of distributed generation placement on power system: A case study of Eko electricity distribution company, LAGOS

To cite this article: P. Bango Owolabi *et al* 2021 *J. Phys.: Conf. Ser.* **1734** 012034

View the [article online](#) for updates and enhancements.

You may also like

- [Optimal location of a single distributed generation unit in power systems](#)
Karrar Mohsin Ajeel
- [Research on DG Capacity Selection Based on Power Flow Calculation](#)
Junjie Ma
- [Pattern separation and completion of distinct axonal inputs transmitted via micro-tunnels between co-cultured hippocampal dentate, CA3, CA1 and entorhinal cortex networks](#)
Daniele Poli, Bruce C Wheeler, Thomas B DeMarse *et al.*



IOP | ebooks™

Bringing together innovative digital publishing with leading authors from the global scientific community.

Start exploring the collection—download the first chapter of every title for free.

Effect of distributed generation placement on power system: A case study of Eko electricity distribution company, LAGOS

Bango Owolabi P., Agbetuyi A.F., Samuel I.A., Abdulkareem A., Adoghe A.U

Department of Electrical Information Engineering, Covenant University, Ota, Ogun state, Nigeria

Corresponding: owolabibango@gmail.com

Abstract. Protection coordination of distribution network has been one of the issues with the distributed generators integration. The reason is that the distribution network is radial in nature by which energy flow is unidirectional. The research aim is to investigate how the location or placement of DG affects the protection setting of the existing network. The healthiness of the test distribution system used in this work is investigated with and without DG connection by use of load flow analysis using Neplan software. The results confirm that the location or placement of DG with the distribution system connection improves the voltage profiles at each bus and active power load loss. The DG placed 1km away from point of common coupling (PCC), the voltage profiles is 10.448Kv with DG connection, and 10.442kV without DG connection, while active power load loss is 69kW with DG connection and 71kW without DG connection. Also, DG placed 6km away from point of common coupling the voltage profiles is 10.404kV with DG connection 10.372Kv without DG connection, while the active power load loss is 110kW with DG connection and 131kW without DG is connected. Moreover, with the DG placed 1km away from the point of common coupling (PCC) the fault current 17.596kA with DG connection and 3.286kA without DG connection, while 6km away from the PCC is 17.543kA with DG connection and 3.286kA without DG connection. It can be concluded that as the distance of the DG from the PCC increases, the fault current also increases which affects the protection scheme of the existing distribution system.

Keywords: Power system, Protection relay, Distributed generators, and Distribution network.

1.0 Introduction

The electric power system is generated from the generating station, transmit via a transmission station, to the power injection substations of the distribution network, and finally to the consumers. The distribution system is designed to extract power from the injection substations, supply the loads but not designed to have distributed generators DGs connected to it directly because of its unique radial or unidirectional flow of energy. The protection and control of distribution networks topology are designed assuming the power flows in one direction, that is, from the transmission to the loads [1]. The main advantage of power generating from the renewable energy sources, such as wind, solar, and biomass are the abundance availability of the resources that can be easily converted into electricity. Wind energy is very clean, available, and without harmful emissions. Due to the effect of the



integration of distributed generators (DGs) on the protection network of the distribution system, many researchers have worked on the solution to the protection issues. The placement of DGs into the conventional radial distribution networks has an adverse effect on the coordination of the overcurrent protection relay between downstream and upstream overcurrent protective devices [2], [3]. Integration of the DGs into distribution system, the network will no longer operate as unidirectional but operate as bi-directional which will cause a loss of coordination among system over current protection schemes [4]. Recalculation of the overcurrent (OC) protection schemes and resizing them, if demanded, will cause miscoordinations to the network. However, in some cases, the coordination of protection relay between downstream and upstream overcurrent protection schemes cannot be maintained (i.e. fuse-fuse or fuse-recloser pairs) due to the current flow through both protection scheme in the presence of the distributed generators (DGs), therefore, coordination of the protection relay at the PCC is necessary [5], [6],[7], [8], [9]. The main purpose of this research work is to investigate how placement or locations of DGs into the distribution network affects the protection schemes and to determine the fault current flow in the system.

2. Literature Review

This section provides review of the related study of the relevant literature. The effect of distribution generators connection to the distribution system has been investigated and it was shown that an increase in DG penetration causes an increase in the short circuit current flow in the system [10]. The severe consequences associated with the integration of DG into the distribution system are nuisance and false tripping, and blinding of protection, mis-coordination of fuse-recloser and fuse-fuse, loss of selectivity and also failed auto reclosing [11] and [12]. Authors [13] and [14] investigated the impact of DGs on location; type, size, and the overcurrent relay coordination with the distribution system and concluded that the penetration of DGs affects the protection system of the distribution network. His work shows that DG impact on the distribution network affects the overcurrent protection scheme coordination which depends on the size, type, and placement or location of the DG.

According to [15], the existing protection coordination of the distribution system will be affected with DG connection. Authors [16] and [17] used IEEE 34 node test network to investigate the integration of DGs on the protection coordination that constituted issues between the auto-reclosers and fuse in the distribution networks and their result shows that DG penetration on distribution system increased the short circuit current which affect the existing protection of the distribution network. Authors [18] and [19] analyzed the importance of DG location on the distribution network and the effect of short circuit current and losses that result in the setting of the relay of the existing distribution system to prevent false and blinding of tripping. According to [20], [21], false tripping of feeders occurs due to the short circuit currents flow in the system with DGs connected to the distribution system. Also, blinding of protection and nuisance tripping are investigated by the authors [22], [23], [24] and [25] with DG connection to the distribution system which resulted to resetting of the relay of the existing distribution network to prevent blinding and nuisance tripping of the system.

In this research work, the load flow analysis of the test distribution network is first analyzed using Neplan software to confirm the healthiness of the distribution system before and after the integration of DG. The location or placement of DGs into the distribution system is analyzed with the voltage profiles in each bus, relay tripping time, losses, and fault current in the system.

3.0 Materials and Method

The test distribution system is being modeled using Neplan software. The distribution network components parameters and data are collected from the Eko Electricity Distribution Company that includes the transmission line, buses, power transformers, and the information of load. The load flow

analysis is being carried out on the test distribution network with or without distributed generators connection. The purpose of load flow analysis study is to investigate if the distribution system is healthy enough to accommodate the DG, the flow of active and reactive power loss within the specified limits and the fault current flow in the network are also determined. The load flow analysis was carried out on the network in order to assess the steady-state performance of the distribution system under no-fault conditions. Modeling test distribution network for protection relay coordination with Neplan software. Simulation of the entire distribution system is carried out to investigate the effects of the penetration level of DG connection to the distribution system.

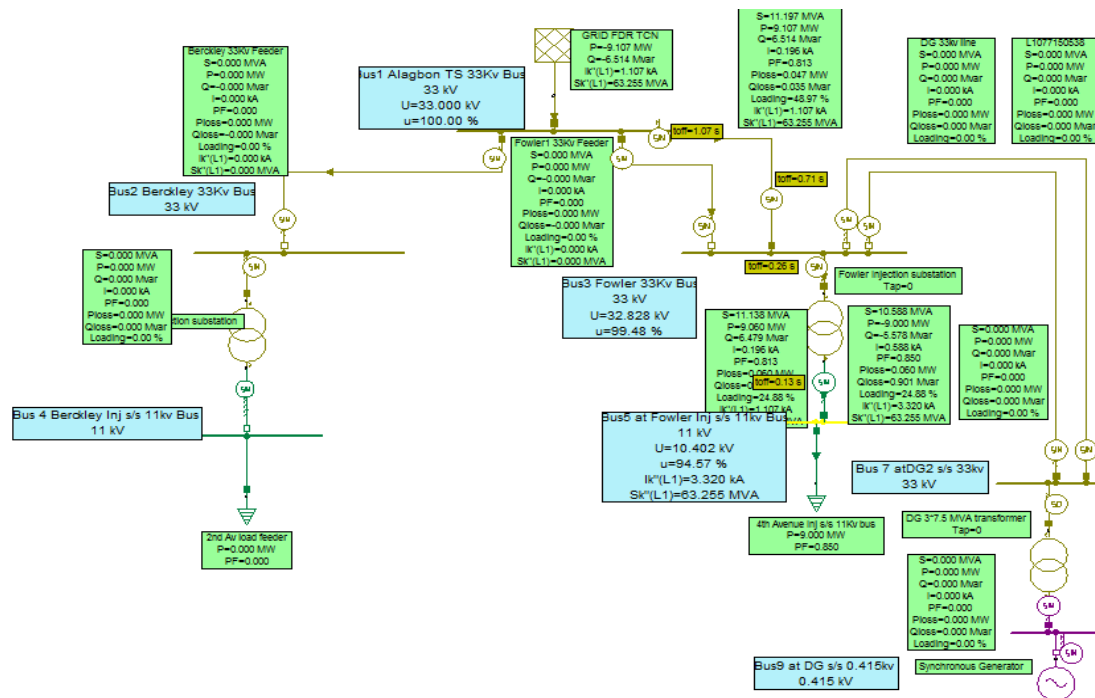

Figure 1: Entire one-line diagram of the modeled distribution system with DG

From the one-line diagram of the test distribution network in Figure 1, the distribution system is being fed from the Transmission Company of Nigeria (TCN) grid Alagbon with data of real power 17.362MW and reactive power 0.308Mvar connected to 33kV bus1. The 3nos 33kV lines that radiated from TCN are Beckley, 33kV single line, and Fowler 1&2, 33kV line double circuit. The lengths of the two feeders to the load are 4km and 6km respectively. Berkley, 33Kv line feeds Berkley Injection substation via 33kV bus2, the primary of 15MVA power transformer is connected to bus2 while the secondary side is connected to 11kV load bus4 with 8.3MW load. The location or placement of units of hybrid generators (wind turbine plus diesel) rating 25MW are varied from 1km, 2km,3km,4km, 5km, and 6km are connected to 33kV bus3 away from the point of common coupling by 33kV line double circuit via 33kV bus7 with power transformer and 0.415kV bus9 with 9MW load. The Interconnector line is connected to the bus2 and bus3 for flexibility of the network. The line impedance of the distribution network used for this research is $R = 0.101$ and $X = j0.077$, as collected from the utility company. From this, it can be seen that the R/X Ratio is 1.311688, which is high compare to the transmission network which is always less than 1. The conventional load flow analysis will not converge for the distribution network due to the high R/X Ratio. Therefore NEPLAN software is used to carry out the load flow analysis of this research work. Figure 2 represents a single line diagram of the test distribution network without DG connected.

3.1 Wind Turbine Model

Aerodynamic system of the wind turbine is the turbine rotor and its blade. Turbine rotor reduces the airspeed which transforms kinetic energy absorbed from air flow into the mechanical power P_{ae} .

Aerodynamics rotor represented the statics relation [26]

$$P_{ae} = \frac{1}{2} \rho \pi R^2 V_{eq}^3 C_p(\theta_{pitch}, \lambda) \quad (1)$$

Where aerodynamic power of the airflow is P_{ae} [Watt],

ρ Air density known as 1,225Kg/m³

The coefficient power C_p is depends on the pitch angle θ_{pitch} in [degree], speed ratio of the tip $\lambda = \omega_{rot} \cdot R / V_{eq}$ the ratio of the blade and the tip speed $\omega_{rot} \cdot R$ and speed V_{eq} [m/s].

Rotor radius R and ω_{rot} is speed of the rotor.

Equation (1) is the power of a particular wind turbine extract from the wind which is known as cubic of the wind speed.

Determination of the aerodynamic power, cause the aerodynamic torque to be calculated directly by,

$$T_{ae} = \frac{P_{ae}}{\omega_{rot}} = \frac{1}{2\lambda} \rho V_{eq}^2 C_p(C_{pitch}, \lambda) \quad (2)$$

Mechanical input is selected either by mechanical power or by mechanical torque, which make other quantity to be calculated by equation (2). Although, the two ways are possible, representation of constant power can be used for modeling. When constant torque is applied, the mechanical power used for the modeling will vary proportionally to the rotational speed. It may result in numerically unstable model system [26, 27].

C_p is developed to calculate the numerical approximation for a given values of θ and λ as

$$C_p(\theta, \lambda) = 0.22 \left(\frac{116}{\lambda_i} - 0.4\theta - 5.0 \right) e^{\frac{-12.5}{\lambda_i}} \quad (3)$$

$$\text{With } \lambda_i = 1 / \left(\frac{1}{\lambda + 0.08\theta} - \frac{0.035}{\theta^{3+1}} \right) \quad (4)$$

3.1.1 Internal Combustion Engine Model

Diesel engines are used to power generators and the speed is control by its shaft known as governor. Internal Combustion Engine can be modelled using NEPLAN, it is very flexible and so the engine

parameters can easily be entered. The Input parameters of the Internal Combustion Engine is as shown in table 3.1

Table3.1 Input parameters of the Internal Combustion Engine

Machine rating	11MVA and 12MVA
Engine Speed rating	1800rpm
Number of Cylinders	6
Number of Engine cycles	Four-stroke
Misfired cylinders	None

3.2 Load Flow Analysis Of Distribution System Without And With Dg Connection

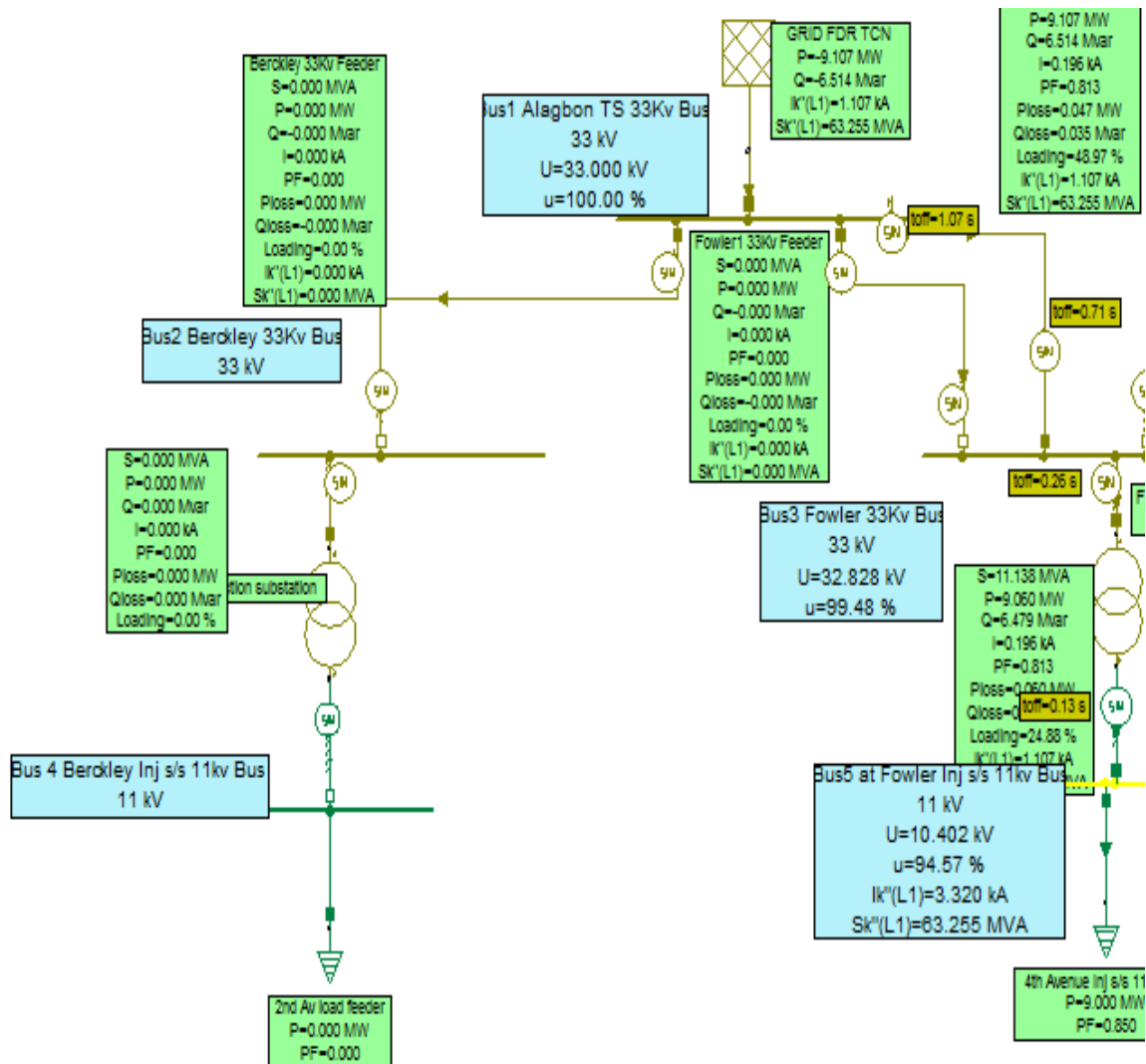

Figure 2: single line diagram of the test distribution network without DG connected

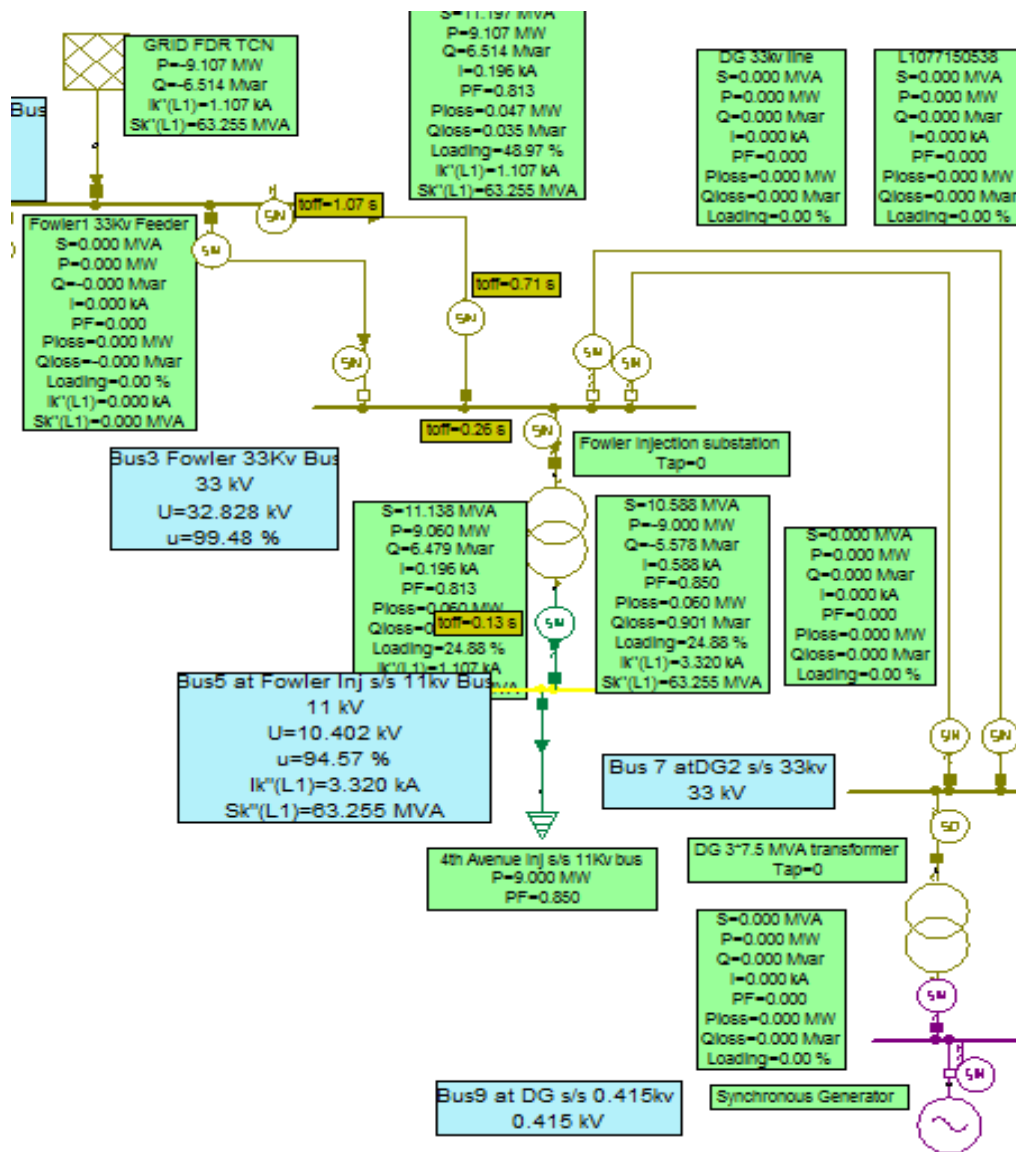

Figure 3: one-line diagram of the test distribution system with DG connected

The load flow analysis results done on the test distribution network with or without DG connection to 33Kv bus3 of Fowler injection substation with 9MW load obtained from the Neplan software shows how the placement of DG affects the voltage profile, load loss, and the fault current of the distribution network when two-phase and three-phase fault are simulated into the network. The results are as shown in the tables below.

Tables 1: Showing the load flow analysis of the test distribution system with two-phase fault when DG is isolated from the network and when DG is connected.

Bus	Nominal voltage (kV)	Bus voltage (kV)	Voltage (p.u)	Load loss (KW)	Status
1	33	32.827	0.995	107	without DG
3	33	32.26	0.995		
5	11	10.402	0.946		
6	11	10.999	0.999	93	with DG
3	33	32.996	0.999		
5	11	10.463	0.951		

Table 2&3 show the simulation of two-phase fault into the test distribution network without and with DG connected at the bus5 Fowler injection substation.

Table 2, two-phase fault without DG connected to test distribution network

Distance (km) of DG from (PCC)	Voltage (kV)	Load loss (kW)	Fault current (KA)
1	10.442	71	2.92
2	10.433	83	2.905
3	10.418	95	2.875
4	10.402	107	2.87
5	10.387	119	2.861
6	10.372	131	2.846

Figure 3 shows the graphical representation of two-phase fault, how the variation of the location or placement of DG affects the voltage profile, load loss, and fault current without DG connected with the test distribution network.

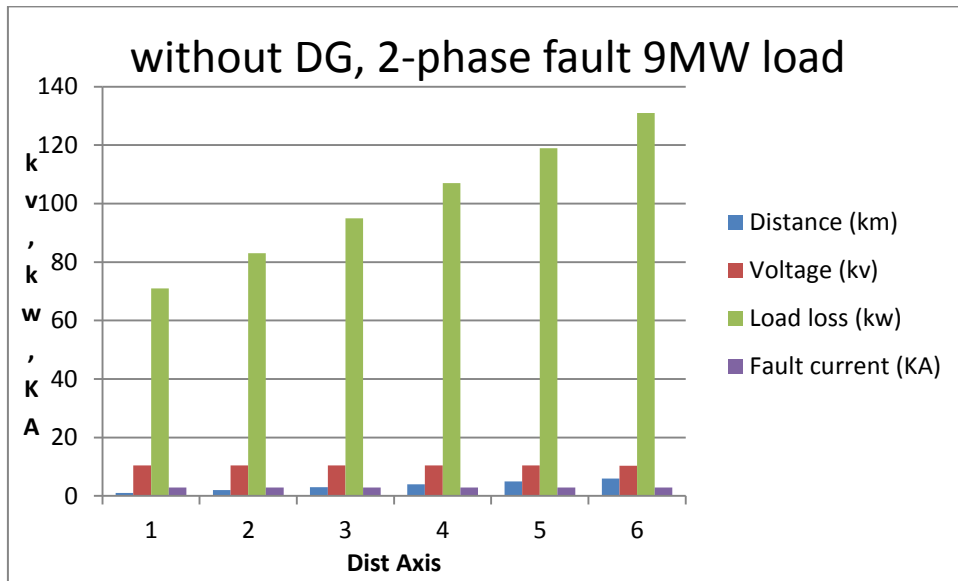

Figure 4: Graphical representation without DG connected to the network

Table 3, two-phase fault with DG connected to test distribution network

Distance (km) of DG from (PCC)	Voltage (kV)	Load loss (kW)	Fault current (KA)
1	10.448	69	17.553
2	10.434	77	17.543
3	10.427	85	17.532
4	10.419	93	17.522
5	10.411	101	17.511
6	10.404	110	17.5

Figure 4 shows the graphical representation of two-phase fault, how the variation of the location or placement of DG affects the voltage profile, load loss, and fault current with DG connected to the test distribution system.

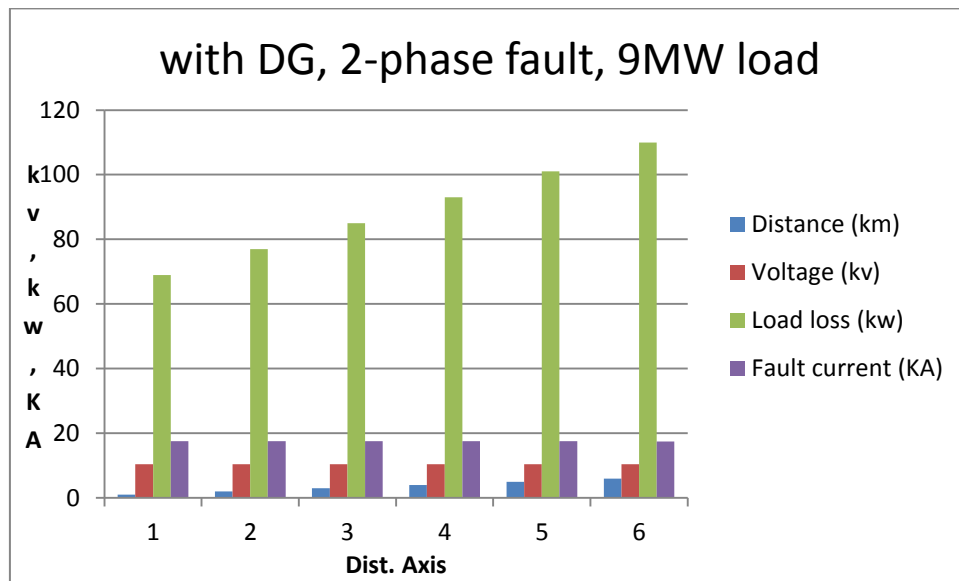

Figure 5: Graphical representation with DG connected to the network

Tables 4&5 show simulation of two-phase fault into test distribution network without and with DG connected at the bus5 Fowler injection substation. Table 4, three-phase fault without DG connected to test distribution network

Table 4, three-phase fault without DG connected to test distribution network

Distance (km) of DG from (PCC)	Voltage (kV)	Load loss (kW)	Fault current (KA)
1	10.448	71	3.371
2	10.433	83	3.354
3	10.418	95	3.337
4	10.402	107	3.32
5	10.387	119	3.303
6	10.372	131	3.286

Figure 5 shows graphical representation of the three-phase fault, how the variation of the location or placement of DG affects the voltage profile, load loss, and fault current without DG connected to the test distribution network.

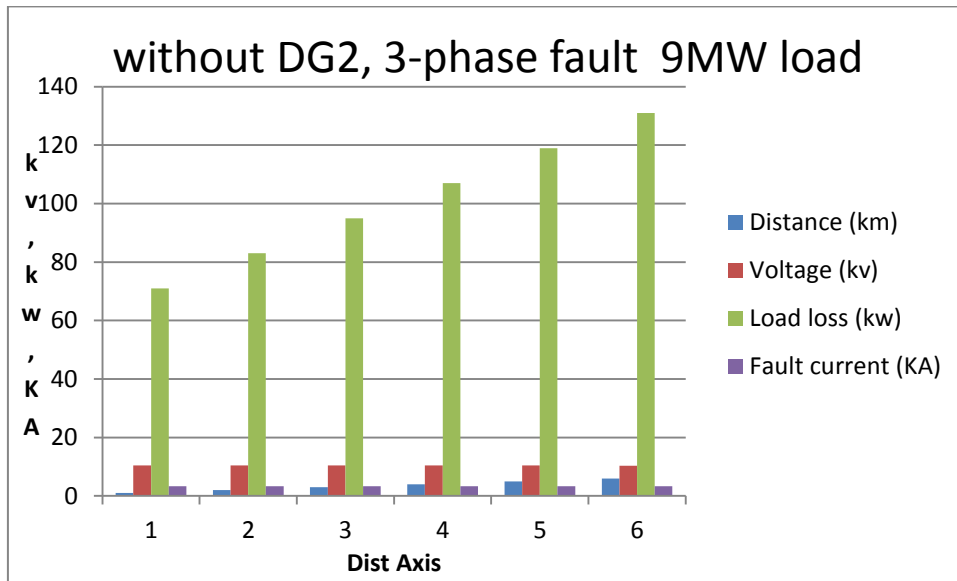

Figure 6: Graphical representation without DG connection to the network

Table 5, three-phase fault with DG connection to test distribution network

Distance (km) of DG from (PCC)	Voltage (kV)	Load loss (kW)	Fault current (KA)
1	10.442	69	17.596
2	10.434	77	17.585
3	10.427	85	17.574
4	10.419	93	17.564
5	10.411	101	17.553
6	10.404	110	17.543

Figure 6 shows the graphical representation of three-phase fault, how the variation of the location or placement of DG affects the voltage profile, load loss and fault current with DG connected to the test distribution network while Figure 7 shows the graphical representation with DG connected to the network.

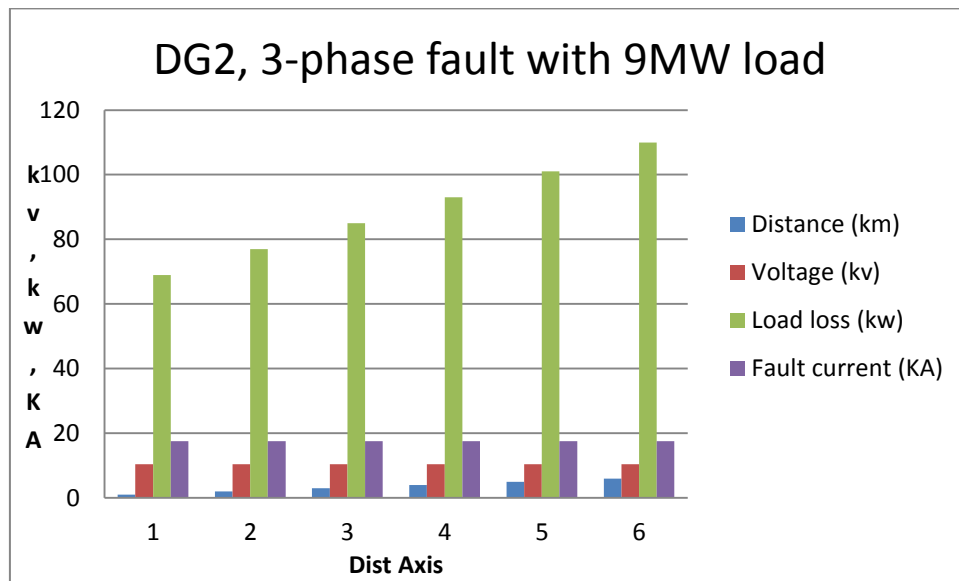

Figure 7: Graphical representation with DG connected to the network

4.0 Analysis of Results

The results on table1 show the load flow analysis which carried out on the test distribution network away from the point of common coupling, the active power load loss without DG is 107kW and 93kW with DG connection to the network. Also the voltage profiles at buses 1, 3 and 5 are 0.995p.u, 0.995p.u and 0.946p.u respectively without DG connection while voltage profiles at bus 6, 3 and 5 are 0.999p.u, 0.999p.u and 0.951p.u respectively with DG is connection to the network. The results show that the active power load loss and voltage profiles at each bus improved with DG connection to the test distribution system. From load flow analysis results, it can be concluded that the test distribution system is healthy enough to accommodate the DG as seen from the results on table1.

Result of the simulation of two-phase fault into the test distribution network without or with DG connected is as seen from tables 2 and 3. The result shows that the voltage profiles improves as the distance of the line is nearer the point of common coupling (PCC), that is, when DG is place at 1km away from the PCC, the voltage profile is 10.448kV, but without DG connection, the voltage profile is 10.442kV while placed at 6km away from the PCC, the voltage profile is 10.404Kv, and without DG connection, the voltage profile is 10.372kV. This reveals that there are voltage drop along the line as the DG is placed far away from the PCC. However, the load loss also increases as the DG placed far away from the point of common coupling. That is when DG is placed 1km away from the PCC; the load loss is 69kW, but 71kW when DG is not connected. While DG placed 6km away from PCC the load loss is 110kW, but 131kW without DG is connected. The results show that the nearer the distance of the placement of DG to the PCC, the lower the active power load loss in the network [10]. Moreover, the fault current at 1km away from the PCC is 17.553Ka with DG connection, but 2.92kA when DG is not connected, also, when placed 6km away from the PCC the fault current is 17.5kA with DG connection, but 2.846kA without the connection of DG. The results generally show that integration of DG into network increase the short circuit current.

Result of the simulation of two-phase fault into the test distribution network without or with DG connected is as seen from tables 2 and 3. The result shows that the voltage profiles improves as the distance of the line is nearer the point of common coupling (PCC), that is, when DG is place at 1km away from the PCC, the voltage profile is 10.448kV, but without DG connection, the voltage profile is

10.442kV while placed at 6km away from the PCC, the voltage profile is 10.404Kv, and without DG connection, the voltage profile is 10.372kV. This reveals that there are voltage drop along the line as the DG is placed far away from the PCC. However, the load loss also increases as the DG placed far away from the point of common coupling. That is when DG is placed 1km away from the PCC; the load loss is 69kW, but 71kW when DG is not connected. While DG placed 6km away from PCC the load loss is 110kW, but 131kW without DG is connected. The results show that the nearer the distance of the placement of DG to the PCC, the lower the active power load loss in the network [10]. Moreover, the fault current at 1km away from the PCC is 17.553Ka with DG connection, but 2.92kA when DG is not connected, also, when placed 6km away from the PCC the fault current is 17.5kA with DG connection, but 2.846kA without the connection of DG. The results generally show that integration of DG into network increase the short circuit current.

From these results, it shows that the nearer the placement or location of DG to the PCC in a distribution network the better the improvement of voltage profiles, and active power load loss of the network. Also the short circuit current decreases as DG is placed away from the PCC. The integration of DG with distribution network always causes an increase with short circuit current flow in the system, the nearer the fault to the PCC the higher the short circuit current flow in the system which always affects the protection scheme of the existing distribution system [10], [18] and [19]. The increase of short circuit current flow with DG connection to the distribution system calls for protection setting of the protection relays of the existing distribution system at the PCC to prevent blinding of protection, false and nuisance tripping of the network.

Conclusion

The result of the research work confirms that the nearer the location or placement of DG to the PCC the better of voltage profile improvement at each bus of the network and active power load loss in the system. As the DG is placed at some kilometer away far from the PCC, fault current also decreases which also confirm that the nearer the integration of DG with distribution system the higher the fault current flow in the system and cause the protection scheme of the existing distribution system to be reset at the point of common coupling.

References

- [1] Hadi Zayandehroodi, Azah Mohamed, Hussain Shareef, and Marjan Mohammadjafar, "Impact of distributed generations on power system protection performance" Vol. 6(16), pp. 3999-4007, 18 August 2011
- [2] T.M. de Britto, D.R. Morais, M.A. Marin, J.G. Rolim, H.H. Zurn, R.F. Buendgens, "Distributed Generation Impacts on the Coordination of Protection Systems in Distribution Networks," Transmission and Distribution Conference and Exposition: Latin America, 2004 IEEE/PES, pp. 623-628, 8-11 November 2004.
- [3] A. Girgis, S. Brahma, "Effect of Distributed Generation on Protective Device Coordination in Distribution System," Power Engineering, 2001 LESCOPE '01. 2001 Large Engineering Systems Conference on, pp. 1151-19, Halifax, NS, 2001
- [4] Brahma SM, Girgis AA (2004). "Development of adaptive protection scheme for distribution System with high penetration of distributed generation." IEEE Trans. Power Deliv., 19(1): 56-63.
- [5] P.M. Koumba, A. Chériti, M. L. Doumbia, "Impacts of Distributed Generation on the Coordination of Protective Devices in Distribution network," Electrical and Computer

- Engineering (CCECE), 2015 IEEE 28th Canadian Conference on, pp. 460-465, 3-6 May 2015.
- [6] J.A. Silva, H.B. Funmilayo, K.L. Bulter-Purry, "Impact of Distributed Generation on the IEEE 34 Node Radial Test Feeder with Overcurrent Protection," Power Symposium, 2007 NAPS '07 39th North American, pp. 49-57, 30 September 2007-2 October 2007.
- [7] H. Cheung, A. Hamlyn, L. Wang, C. Yang, R. Cheung, "Investigations of Impacts of Distributed Generations on Feeder Protections," 2009 IEEE Power & Energy Society General Meeting, pp. 1-7, 26-30 July 2009.
- [8] M.E. Baran, H. Hooshyar, Z. Shen, A. Huang, "Accommodating High PV Penetration on Distribution Feeders," IEEE Transactions on Smart Grid, vol. 3, no. 2, pp. 1039-1046, June 2012.
- [9] K. Kauhaniemi, L. Kumpulainen, "Impact of Distributed Generation on the Protection of Distribution Networks," Developments in Power System Protection, 2004 Eighth IEE International Conference on, vol. 1, pp. 315-31, 5-8 April 2004
- [10] S. P George, S. Ashok, and M. N Bandyopadhyay, "Impact of Distributed Generation on Protective Relays", Inter Conf on Renewable Energy and Sustainable Energy [ICRESE'13], 2013.
- [11] M. Singh, "Non-Adaptive Over Current Relay Coordination in Distribution Systems", IEEE International Conference on Power Electronics, Drives and Energy Systems (PEDES), 2014
- [12] S. Nikolovski, M. Havranek, and P. Marić, "Numerical Relay Protection Coordination using Simulation Software", MIPRO, May 20-24, 2013
- [13] S. Conti, "Analysis of Distribution Network Protection Issues in Presence of Dispersed Generation", Electric Power Systems Research, Vol. 79, No. 1, pp. 49-56, 2008.
- [14] Doyle MT (2002) Reviewing the Impacts of Distributed Generation on Distribution System Protection, Power Engg. Soc. Summer Meeting, IEEE. 1,103-105
- [15] Chaitusaney S and Yokoyama A (2006) Reliability analysis of distribution system with distributed generation considering loss of protection coordination. 9th Intl. Conf. on Probabilistic Methods Applied to Power Sys. pp: 1-8.
- [16] IEEE PES Distribution test feeder working group, 2010, "34 Node Test Feeder", available online: ewh.ieee.org/soc/pes/dsacom/testfeeders/
- [17] J. A. Silva, H. B. Funmilayo, K. L. Butler-Purry, 2007, "Impact of Distributed Generation on the IEEE 34 Node Radial Test Feeder with Overcurrent Protection", 39th North American Power Symposium, 49-57.
- [18] W. El-Khattam and M. M. A. Salama, "Impact of distributed generation on voltage profile in deregulated distribution system," in Proc. PowerSystem Conf., Clemson, SC, 2002.
- [19] T. Griffin, K. Tomsovic, D. Secrest, and A. Law, "Placement of dispersed generations systems for reduced losses," in Proc. 33rd Hawaii Int. Conf. System Sciences, 2000.

- [20] R. A. Walling, R. Saint, R. C. Dugan, J. Burke and L. A. Kojovic, "Summary of Distributed Resources Impact on Power Delivery Systems," IEEE Tran. On Power Delivery, vol. 23, no. 3, pp. 1636-1644, Jul. 2008
- [21] G. Kaur and M. Vaziri Y., "Effect of Distributed Generation (DG) Interconnections on Protection of Distribution Feeders," in Proc. 2006 IEEE Power Engineering Society General Meeting, pp. 8.
- [22] E. Coster, J. Myrzik and W. Kling, "Effect of Distributed Generation on Protection of Medium Voltage Cable Grids," in Proc. 2007 International Conference on Electricity Distribution, pp. 4.
- [23] K. Kauhaniemi and L. Kumpulainen, "Impact of Distributed Generation on the Protection of Distribution Networks," in Proc. 2004 IET International Conference on Development in Power System Protection, vol. 1, pp. 315-318.
- [24] W. G. Hartmann, "How to Nuisance Trip Distributed Generation," in Proc. 2003 IEEE Rural Electric Power Conference, pp. C.5-1 –C.5-11.
- [25] W. G. Hartmann, "How Not to Nuisance-Trip Distributed Generation," in Proc. 2005 IEEE Technical Conference on Industrial and Commercial Power System, pp. 52-61.
- [26] Agbetuyi A. Felix, Akinbulire T.O, Abdulkareem A, Awosope C.O.A (2012) "Wind Energy Potential in Nigeria" IEEE Journal, 3(1). Pp. 595-601, ISSN 2078-2365
- [27] Agbetuyi A.F., Awosope C.O.A., Samuel I.A., Ademola A., Awelewa A.A. "Dynamic Stability of a distribution system with wind turbine generators connected" International Journal of Mechanical Engineering and Technology(IJMET), Volume 9, Issue 11, November 2018, Pages 2453-2461