



Review article

Drivers of anthropogenic air emissions in Nigeria - A review

Oyetunji B. Okedere^a, Francis B. Elehinfafe^{b,*}, Seun Oyelami^c, Augustine O. Ayeni^b^a Department of Chemical Engineering, Faculty of Engineering and Environmental Sciences, Osun State University, Nigeria^b Department of Chemical Engineering, School of Chemical and Petroleum Engineering, College of Engineering, Covenant University, Ota, Ogun State, Nigeria^c Department of Mechanical Engineering, Faculty of Engineering and Environmental Sciences, Osun State University, Nigeria

ARTICLE INFO

Keywords:

Anthropogenic sources
 Drivers of air pollutants
 Emission inventory
 Energy
 Wastes
 Nigeria

ABSTRACT

This study presents a review of sources and atmospheric levels of anthropogenic air emissions in Nigeria with a view to reviewing the existence or otherwise of national coordination aimed at mitigating the continued increase. According to individual researcher's reports, the atmospheric loading of anthropogenic air pollutants is currently on an alarming increase in Nigeria. Greater concerns are premised on the inadequacy existing emission inventories, continuous assessment, political will and development of policy plans for effective mitigation of these pollutants. The identified key drivers of these emissions include gas flaring, petroleum product refining, thermal plants for electricity generation, transportation, manufacturing sector, land use changes, proliferation of small and medium enterprises, medical wastes incineration, municipal waste disposal, domestic cooking, bush burning and agricultural activities such as land cultivation and animal rearing. Having identified the key sources of anthropogenic air emissions and established the rise in their atmospheric levels through aggregation of literature reports, this study calls for a review of energy policy, adoption of best practices in the management air emissions and solid wastes as well as agriculture and land use pattern which appear to be the rallying points of all identified sources of emission. The study concluded that the adoption of cleaner energy policies and initiatives in energy generation and usage as against pursuit of thermal plants and heavy dependence on fossil fuels will assist to ameliorate the atmospheric loadings of these pollutants.

1. Introduction

Atmospheric pollution by air emissions is increasingly becoming a subject of worry to governments, non-governmental organizations and researchers at the global level. This is especially due to the observed and reported adverse effects on air quality and global climates with humans, animals, and the inanimate components (vegetation, structure and oceans) of the environment bearing the brunt. The attention given to air pollution is also premised on its global nature; that is, the possibility of adverse effects being felt in places other than the sources of emission (Sonibare et al., 2007; Oladimeji et al., 2015a,b; Okedere et al., 2018). Exposure to air pollution is closely connected with the burden of disease all over the world and accounts for one in every nine mortalities on annual basis (WHO, 2016). Anthropogenic sources and emission levels of air pollutants vary across the globe depending on the level of advancement and technological development of a country, living standard; cultural beliefs of people in a given society and management strategies put in place. Prominent among the leading causes of air emissions worldwide are power generation plants (Sonibare 2010; Chen, 2017; Medeiros et al.,

2017; US EPA, 2017; US EPA, 2018; Tiwari et al., 2019; Strasert et al., 2019); traffic and transportation system (Fakinle et al., 2013, 2020; Jandacka et al., 2017; Kurnyina et al., 2018); petroleum refining (Damian, 2013; Oladimeji et al., 2015a,b; Ragothaman and Anderson, 2017; Haridoss, 2017); industrial manufacturing processes and services (Al-Hasnawi et al., 2016; Okedere et al., 2018; Adeyanju and Okeke, 2019) and gas flaring. Notable among the air pollutants are carbon monoxide (CO), carbon dioxide (CO₂); oxides of nitrogen (NO_x); sulphur di oxide (SO₂); particulate matter (PM_{2.5} and PM₁₀), black carbons, organic carbons; heavy metals; volatile organic compounds (VOCs); Straight-chain hydrocarbons; polycyclic aromatic hydrocarbons (PAHs); persistent organic pollutants (POPs) and ground level ozone (O₃).

According to USAID report, Nigeria generated about 492.44 million metric tons of greenhouse gases (GHGs) (MtO₂e) in 2014 and increase of about 25% over their 1990 value and 1.01% of the global GHGs.

While there has been no lack of air pollution studies in the Nigeria, there are however no continuous and systematic studies leading to absence of yearly pool of data on air pollutions to assist national policy formulation. Also, political will has not been strong enough to address

* Corresponding author.

E-mail address: francis.elehinfafe@covenantuniversity.edu.ng (F.B. Elehinfafe).

most of these challenges. This review is an attempt to delve into peculiarity of the sources and extent of anthropogenic air pollution in Nigeria by aggregation research studies. It is also aimed at suggesting possible management strategies that can be adopted at the national level.

2. Common anthropogenic air pollutants: sources and adverse effects

2.1. Carbon monoxide and carbon dioxide

Carbon monoxide is a product of incomplete or partial combustion of any carbonaceous material. Carbon is ubiquitous as it forms the basic bedrock of animates, vegetations and fossils. Thus, whenever any of these materials undergoes combustion, CO is emitted since there is usually not a perfect mix of air and fuel to bring about 100% burning process (Zajemska et al., 2014). The major adverse effect of CO is on human health where it combines with certain component of the blood known as haemoglobin. The resultant product which is carboxy-haemoglobin has been reported to seriously exert highly detrimental adverse effect on the human blood circulatory system. It is known to starve the blood of oxygen and has been fingered in many cases of near death and mortalities (Zevin et al., 2001; Lifespan, 2018; Sonibare, 2010). It also affects the effective functioning of cell mitochondrion (Kim and Choi, 2018). The chemical equation underlining the emission of CO is given in Eq. (1).



Closely associated with carbonaceous materials is the emission of carbon dioxide which is the actual product of a complete oxidation of carbon as shown in Eq. (2). Aside combustion process involving oxidation of carbon, industrial manufacturing process such as cement production involving thermal decomposition of carbonates constitutes the leading global contributor to atmospheric levels of CO₂ (IPCC, 1997). The decomposition of the carbonates takes place at high temperature and is represented with Eq. (3).



CO₂, a greenhouse gas plays a leading role in the global atmospheric chemistry of climate change. While it is not the best heat trapper, it is the most abundant greenhouse gas and global warming potentials of other greenhouse gases are usually expressed in carbon dioxide equivalents.

2.2. Oxides of nitrogen

Oxides of nitrogen (NO_x) comprises nitrous oxide (N₂O), nitric oxide (NO), dinitrogen dioxide (N₂O₂), dinitrogen trioxide (N₂O₃), nitrogen dioxide (NO₂), dinitrogen tetroxide (N₂O₄) and dinitrogen pentoxide (N₂O₅) (US EPA, 1999). However, emphasis has always been on NO₂ because it is the most prevalent and regulated of the NO_x family. While there may be other sources of NO_x, the present review is concerned with anthropogenic sources. Mobile sources (internal combustion engines) and electric power plants are believed to be responsible for 70% of anthropogenic NO_x (US EPA, 1999). The cause of NO_x emission from these two leading sources is combustion. Three mechanisms have been adduced to NO_x formation in combustion processes. First, thermal fixation, which is usually associated with molar concentrations of nitrogen and oxygen as well as combustion temperatures below 1300 °C (US EPA, 1999). Another mechanism is the fuel NO_x which is common to fuels that are highly rich in nitrogen. Under combustion, the ionized nitrogen in the fuel undergoes oxidation to produce NO_x. In any combustion process, fuel-rich condition exists to some extent (US EPA, 1999). Molecular nitrogen in the atmosphere may combine with fuel in this fuel-rich conditions thereby forming NO_x. This is frequently regarded as prompt NO_x formation mechanism. Generally, NO is the predominant form of NO_x

emissions from combustion processes and the Zeldovich Equations representing its formation are given by Eqs. (4), (5), and (6) (US EPA, 1999).

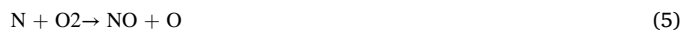
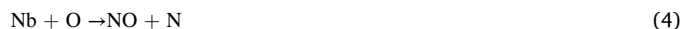

Adverse human health effects of NO_x have been reported in the literatures (Lu et al., 2016; Bernabeo et al., 2019; US EPA, 2019). It is also reported to have deleterious effects on vegetations (Schmutz et al., 1995; Sheng and Zhu, 2019). Apart from being a pollutant with harmful health effects, some components of NO_x (NO₂) readily dissolve in the atmospheric water to produce trioxonitrate v acid (nitric acid) with the attendant acid rain (Singh and Agrawal, 2008; Kumar, 2017). The reaction NO₂ in presence of photons produces NO and Ozone (O₃). Radicals from photo-reactions of NO and volatile organic compounds (VOCs) convert the NO back to NO₂. These chemical reactions which produce ozone may continue to occur in the tropospheric layer of the atmosphere where ozone produces adverse effects on human and environmental health (Sheffield et al., 2011; Zhang et al., 2019). NO_x also plays important roles in the chemistry of climate change. N₂O is a greenhouse gas with capacity to trap heat energy and is therefore one of the precursors of global warming.

2.3. Ground level ozone and photochemical smog

While ozone is friendly in the upper atmosphere as it forms layers which prevent too much ultraviolet rays from reaching the earth; it is however, regarded as unfriendly in the troposphere (lower atmosphere) because of its strong oxidizing nature. Ground level ozone is a secondary pollutant in that it is not emitted by any source but is formed by the interaction of some primary pollutants with some elements of the environment. Apart from its strong oxidizing nature that is not desirable in the lower atmosphere, it is a major player in the formation of photochemical smog. According to US EPA (2004), the chemistry of formation of photochemical smog with ozone as active player is represented with the chemical Equations (7), (8), (9), (10) and (11).

- (i) Formation of nitric oxide and O by reaction of NO₂ with thermal energy from the sun



- (ii) Formation of ozone by reaction of oxygen radical with atmospheric oxygen



- (iii) Reduction of ozone by nitric oxide



- (iv) Formation of harmful product such as peroxyacetyl nitrate (PAN) by reaction of NO₂ with hydrocarbons (R) with VOCs being the major source of the hydrocarbons



- (v) Formation of more NO₂ by reaction of other oxygenated organic and inorganic compounds (RO_x) with NO



As long as VOCs are present, the chemical reactions above will continue to be propagated leading to the building up and accumulation of ground level ozone. Reported human health risks from the inhalation of ozone include irritations, chest pain, throat irritations,

cough and congestion. Other worse conditions include bronchitis, emphysema, asthma, reduction of lung function (Stewart et al., 2017; Zhang et al., 2019). Plants are also not left behind in the adverse environmental effects of ozone as it inhibits plants activities of opening and closing of stomata thereby affecting respiration and photosynthesis (Emberson et al., 2018; IDNR, 2020). The aftermath is poor crop yield and susceptibility of crops to diseases (IDNR, 2020). Photochemical smog being a combination of pollutants (VOCs, NO₂, O₃, PAN and other chemical compounds of the aldehyde group tends to exhibit greater level of adverse effects.

2.4. Oxides of sulphur

Oxides of sulphur are majorly emitted from combustion of sulphur rich fuels such as refined petroleum products (Sonibare, 2010). They are also emitted from combustion activities involving gas flares (Giwa et al., 2019a) and in the extraction process (smelting) of iron from its ores such as pyrites (Runkel and Sturm, 2009; Faruq et al., 2012; Jain et al., 2016; Dmuchowski et al., 2018). The two sources mentioned above are essentially oxidation – reduction reactions where oxygen oxidizes the sulphur in the fuel or ore to release sulphur dioxide (SO₂) as shown in Eqs. (12) and (13). When humans are exposed to SO₂ either via eyes or by inhalation into the nasal cavity, irritations have been reported due to its acid anhydride property (Okedere et al., 2017a). Allergies, inflammation, cardiovascular and respiratory diseases have been associated with exposure to SO₂ (Al-Jahdali and Bisher, 2008). SO₂ uptake by plants have been reported to take place via the stomata and root (Al-Jahdali and Bisher, 2008; Khan and Khan, 2011).



2.5. Particulate matter

Particulate matter can be in the form of solid, granulated solid or even liquid droplet. Their sources are ubiquitous and they vary markedly in sizes and description. Total suspended particulate (TSP) is used to describe particles with broad range of diameters between 0.1 and 30 μm. These could be fine or coarse particles. Others are the inhalable fractions (PM₁₀) having diameter less than 10 μm; the respirable particles (PM_{2.5}) with diameter less than 2.5 μm and ultrafine particles with diameter less than 0.1 μm (Li et al., 2019). The rate of premature mortality due to ambient PM_{2.5} pollution in Nigeria (23.8 premature deaths per 100,000 people) is well above the average for the West Africa region. Major sources include the combustion of gaseous, liquid and solid fuels whether for cooking, transportation, industrial or power generation purposes (Sonibare, 2010; Fakinle et al., 2013; Okedere et al., 2017a; Balmes, 2019). Others include gas flaring, biomass burning, road construction and animal houses (Giwa et al., 2019a; Muleski and Cowherd, 2005; Winkel et al., 2015; Balmes, 2019; Deng et al., 2020). Several epidemiology reports on the effects of PM₁₀ and PM_{2.5} abound (Wyzga and Rohr, 2015; Thompson, 2018). They are fingered as causal agents in respiratory and circulatory diseases. Even when not intrinsically toxic, they serve as carriers and platforms for other pollutants to be transported into the human body (WHO, 2007; Comunian et al., 2020). Polycyclic aromatic hydrocarbons and heavy metals can find their way into the human body by inhalation of particulate matter (Lawal, 2017). Various adverse effects of heavy metals on human, animal, plant, soil and aquatic health also abound (Ogunkunle et al., 2013; Ogunkunle and Fatoba, 2014). By absorption and scattering of radiations, particles have been known to affect visibility with attendant effects of flight navigation (Won et al., 2020).

2.6. Hydrocarbons and volatile organic compounds

Hydrocarbons are usually emitted during production of coal, refining, transportation and utilization of petroleum based products (Sonibare et al., 2007; Sonibare, 2010). They are also emitted from incomplete combustion of fossil fuels; decomposition of biomass; municipal wastes in landfills; cigarette and high temperature grilled meat and food substances (Bonfanti et al., 1994; Zakaria et al., 2005). They could be aliphatic (straight and branch structure) or aromatic (ring structure). The aliphatic groups consist of the homologous series of alkanes, alkenes and alkynes while aromatic groups have ring structures. Typical example of the aliphatic hydrocarbon is methane while benzene and polycyclic structures constitute the aromatic groups. Polycyclic (polynuclear) aromatic hydrocarbons (PAHs) constitute a group of over 100 chemical species but only about 16 of them are listed as priority PAHs by the United States Environmental Protection Agency and are so frequently monitored. The 16 priority PAHs have been reported to be toxic and carcinogenic (Cousin and Cachot, 2014; Das et al., 2014; Abdel-Shafy and Mansour, 2016; Okedere et al., 2019).

Non-Methane Volatile organic compounds (NMVOCs) may arise from burning of biomass and fossils, evaporation of fuels, solvents utilization and some industrial manufacturing processes (Laskar and Younus, 2018). These classes of compounds include benzene and aldehydes and have been reported to directly exhibit major human health risk factors (Laskar and Younus, 2018). They also act as precursors for formation of photochemical smog and ozone which are also harmful to human health. Other adverse effects of VOCs include interference with plant activities of photosynthesis and reproduction.

2.7. Persistent organic pollutants (POPs)

As the name implies, these group of compounds stay long (persist) in the environment. They have tendencies to bio-magnify and accumulate in the ecosystem and can be transported over long distance since they do not degrade easily (Guo et al., 2019). POPs such as dichloro-diphenyl-trichloroethane (DDT) and its metabolites usually originate from the use of organochlorine pesticides (OCPs) while polychlorinated biphenyls (PCB, polybrominated diphenyl esters (PBDEs) and perfluorooctanesulfonates (PFOs) arise from industrial and technical chemicals. Others such as polychlorinated dibenzo-p-dioxins (PCDDs) and polychlorinated dibenzofurans (PCDFs) are usually emitted as by-products of industrial manufacturing processes. Details of Chemical structures of these compounds are already documented by Guo et al. (2019).

2.8. Organic carbon, black carbon, and Brown carbon

Organic carbons emissions are usually associated with incomplete combustion of fossil fuels or biomass. These are common in transportation, power generation, domestic and industrial combustion processes that employ fossil and biomass as fuels (CSE, 2012). Organic carbons constitute a considerable proportion of the total aerosols in the earth's atmosphere. They also to a great extent affect atmospheric chemistry and climate change (Alexander Laskin et al., 2015). Some organic aerosols are categorized as white because they scatter visible radiations. Other ones absorb radiation in the visible and infra red spectrum (Sathesh and Moorthy, 2005). Black carbons are integral part of soot and belong to the second category which absorbs radiations thereby contributing to increase in earth's temperature by efficient absorption and conversion of light to heat energy (Alexander Laskin et al., 2015). Another group of organic aerosols that are capable of absorbing light in the visible and ultraviolet region are the brown carbons. Both black and brown carbons taken by vapour droplets are capable of causing absorption of radiation, dispersion of clouds and negation of cooling effects caused by nucleation of aerosols (Alexander Laskin et al., 2015). Majority of these organic carbons are emitted as ultrafine particles with

attendant impacts on quality of air. Therefore, they constitute major health hazards (Schraufnagel, 2020). Reported health effects include respiratory challenges, cardiovascular diseases and death (Zhou et al., 2009; Rushdi et al., 2017).

3. Drivers of anthropogenic air pollutants in Nigeria

While the sources of these pollutants are essentially the same, attempt is made in this section to look as the present state of research on these pollutants and their drivers in Nigeria. Nigeria is blessed with abundant resources including crude oil and natural gas deposits, solid minerals and vast expanse of arable lands. The population of the country has witness astronomical explosion and with urbanization, there has been increasing pressure and over-stretching of existing facilities which are presently considered grossly inadequate to meet the needs of the present population both in quantity and structure. There is no doubt that the country has struggled over the years to ensure that these potentials are explored to boost economic development and meet the need of the growing population. However, most efforts have not been approached from a sustainable point of view thereby creating environmental concerns. The major drivers of anthropogenic emissions are hereby reviewed.

3.1. Petroleum industry

Crude oil exploration started in Nigeria as far back as late 1930s although it was first discovered in marketable quantity over six decades ago at Oloibiri in present day Bayelsa State of Nigeria (Ogbuigwe, 2018; Sam and Zabbey, 2018). Actual petroleum refining activities in Nigeria started in Port-Harcourt in 1965 with the commissioning of the first refinery by Shell-BP which saw Nigeria acquired 50% shareholding stake. The stake was increased to 60% in 1972 followed by full acquisition in 1978. Since then, three additional refineries including Warri Refinery, Kaduna Refinery and Port-Harcourt Refinery II were commissioned in 1978, 1980 and 1989 respectively. Due to the need to meet increasing local demand and also to increase the revenue accruable to the government, quite a number of additional private owners have been license to operate refineries, a number of which are on-going projects. Petroleum processing involves a number of equipment and stages from where air

pollutants may be emitted. A typical petroleum refinery is shown in Figure 1.

While these refineries have been the main stay of Nigeria's economy (Sam and Zabey, 2018), and have provided well paid employments for thousands of citizenry, they have also been reported to contribute immensely to anthropogenic air pollution in Nigeria (Oladimeji et al., 2015a). Emission of air pollutants may occur at any stage or unit during petroleum refining due to faulty devices and equipment (pumps, seals, pipes etc). The levels of these pollutants are expected to increase when the licensed refineries come on stream. Sonibare et al. (2007) adopted the emission inventory approach to examine the contribution of petroleum refining to airshed loading of volatile organic compounds in Nigeria and concluded that uncontrolled emission of VOCs from the four existing refineries amounted to 147,212 tons per annum with a potential to increase by 240 % if the licensed refineries come on board. Oladimeji et al. (2015a) expanded the scope of the inventory to cover other criteria air pollutants. About 1,217 tons/annum; 45,124 tons/annum; 167,570 tons/annum and 242,469 tons/annum of PM, SO₂, NO_x and CO, respectively were estimated to be contributed by the existing refineries. While air emissions are usually transported over a long distance in a plume by atmospheric dispersion processes (Oladimeji et al., 2015a; Okedere et al., 2017; Fakinle et al., 2017); research reports indicate that the impact of the air emissions from the Nigerian petroleum industry is largely felt in the Niger Delta region that houses the four existing refineries (Sonibare et al., 2007; Sonibare, 2010; Oladimeji et al., 2015a; Bebetidoh et al., 2020). The per capita and land distributions were reported to be higher in this place than in the rest of the country (Sonibare, 2010).

Apart from the crude and atmospheric distillation and fluid catalytic cracking units of the refineries, the upstream sectors of the Nigerian petroleum industry have also been reported to contribute significantly to atmospheric levels of anthropogenic air pollutants. Notable among the upstream activities with significant adverse human and environmental effects are the gas flares. As at 2000, gas flaring was the largest emission contributor in Nigeria's energy sector. It accounted for a little above 40% of the total energy emissions (NCC, 2014). Until recently, bulk of the associated gas in the Nigerian oil and gas field was flared since its usage was not planned for at the initial phase (Sonibare and Akeredolu, 2004).

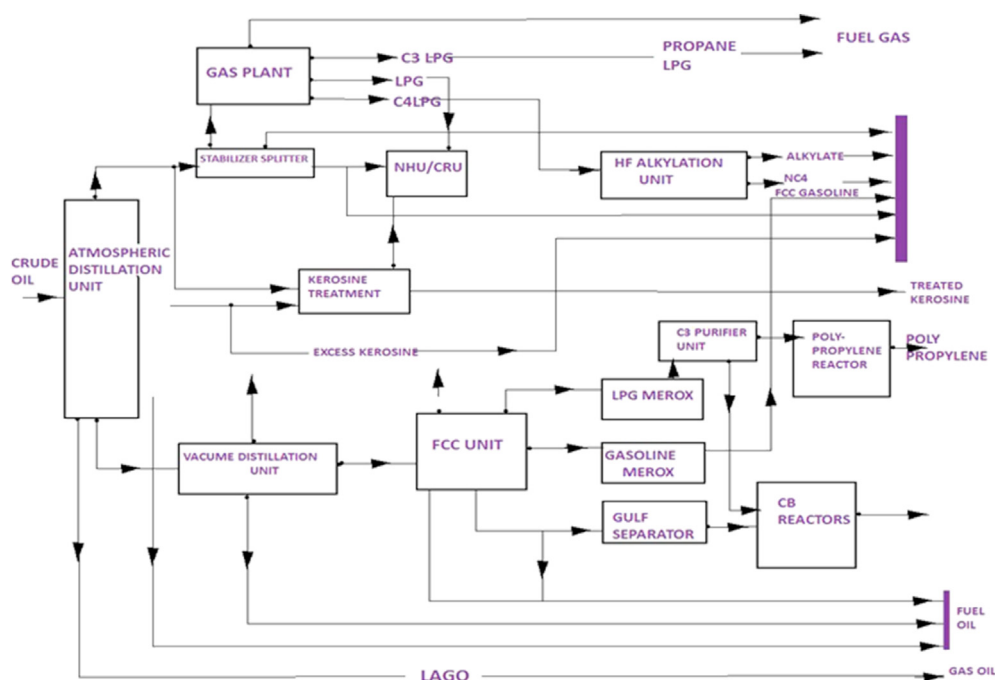

Figure 1. Block diagram of a typical petroleum refinery.

Gas flaring is the disposal of flammable waste gases either in the upstream or downstream petroleum industry. Although there are many configurations of flares, a typical gas flare commonly used for combustion of waste gases in the petroleum industry is shown in Figure 2. Flares are usually tall stacks whose tips are open to air and where associated gases are burnt (Akeredolu and Sonibare, 2004). Ejiogu (2013) reported that Nigeria was the second gas flaring nation in the world. Even with government's deliberate efforts to cut down gas flaring, Nigeria still ranks among the top seven gas flaring nations in the world according to a recent report which is shown in Table 1. According to Giwa et al. (2019a), slightly above 51% of the gas produced over a period of five decades were believed to have been flared as at 2015. Gas flaring over this period was also reported to be associated with emissions of CO, NO_x, SO_x, NMVOCs, PM_{2.5} and organic carbons (OC) between 10,500 – 5,100,000 tons with SO_x and CO constituting the least and maximum emitted pollutants, respectively. Although, there has been a drastic reduction in gas flaring in Nigeria to about 10% in the recent time, this is still enormous and the country still ranks in the top 10 among countries that are still engaging in the practice (PWC, 2018). The adverse effects of gas flaring are still being experienced to a great extent in the Niger Delta region of the country.

A strong connection between gas flaring by oil companies in the Niger Delta region of Nigeria and air and thermal radiations have been reported by Agboola et al. (2020). Infra red radiations and heat fluxes from gas flares have detrimental effects on eco - system balances (Ismaila and Fagbenle, 2020). A link between gas flaring and acid rain as well rapid corrosion of roofing sheet has been reported by Ekpoh and Obia (2010). Surface and ground water are reported to be affected by gas flaring (Nwankwo and Ogagarue, 2011). In general, gas flaring has significant effects on the socio-economic life of the people of Niger -Delta region where these activities take place. Destruction of vegetations, reduction of crop yield, pollution of aquatic systems and incidences of diseases are among the major challenges associated with gas flaring in Nigeria. The development of liquefied petroleum gas industry is seen by many as the way out of the challenges posed by gas flaring as various deadlines for stoppage of gas flaring have not worked out (Sonibare and Akeredolu 2004; Agboola et al., 2020). Although, the domestic market for LPG consumption is on the increase in Nigeria, the penetration level is still very low. In order to further cut down or completely eliminate routine

flaring of gases, it is recommended that the LPG market expansion be aggressively pursued.

3.2. Thermal plants for electricity generation

Nigeria electricity industry comprises a mix of hydro electricity stations and gas fired thermal plants (Sonibare, 2010). The first generations of power stations in Nigeria were commissioned between 1965 and 1990 and these include Afam Thermal (971 MW, Rivers); Delta Thermal (912 MW, 1966); Kainji Hydro (760 MW, 1968); Sapele Thermal (1020 MW, 1978); Lagos thermal (1320 MW, 1985); Jebba Hydro (576 MW, 1986) and Shiroro Hydro (600 MW; 1990) (Sambo et al., 2014). Increase in population, infrastructural development, industrial and small and medium enterprises growth among other reasons have necessitated the need for additional power generation. For instance, the population figure of Nigeria in 1991 was about 93 million while the last official census figure was 140 million (NPC, 1991; NPC, 2007). At a population growth rate of 2.5%, the present population is believed to be about 190 million people. These led to the licensing of additional power stations including National integrated Power Plants (NIPPs) (13 Stations), Joint Ventures integrated Power Plants (JVIPPs) (5 Stations) and Independent Power Plants (IPPs) (NERC, 2008; Sonibare, 2010). As at 2017, about 40 thermal plants were fully operational. Effort is on-going on additional 18 (Odehale et al., 2017). Even with additions, current realities show that these power stations have not been able to meet the energy need of the country (Oladipo et al., 2018; CEIC, 2020).

A closer look at the power generation station mix revealed that, a significant proportion of the installed capacities of all the power stations in Nigeria are from thermal plants. Thermal plants rely on gas - fired turbines to generate electricity giving rise to air pollution concerns as a result of combustion of fossil fuel. Energy and power production systems operating on fossil fuels have been reported to contribute significantly to anthropogenic air emissions (Fridell et al., 2008; Ramanathan and Carmichael, 2008). Studies on contributions of electricity generating stations to anthropogenic emissions in Nigeria are scanty; though, the thermal plants are reported to release significant levels CO, NO_x, SO_x, PM and VOC in to the country's airshed (Sonibare, 2010; Odehale et al., 2017). On the average, operational thermal plants in Nigeria currently deliver at about 40% of the installed capacity and emit only a little less

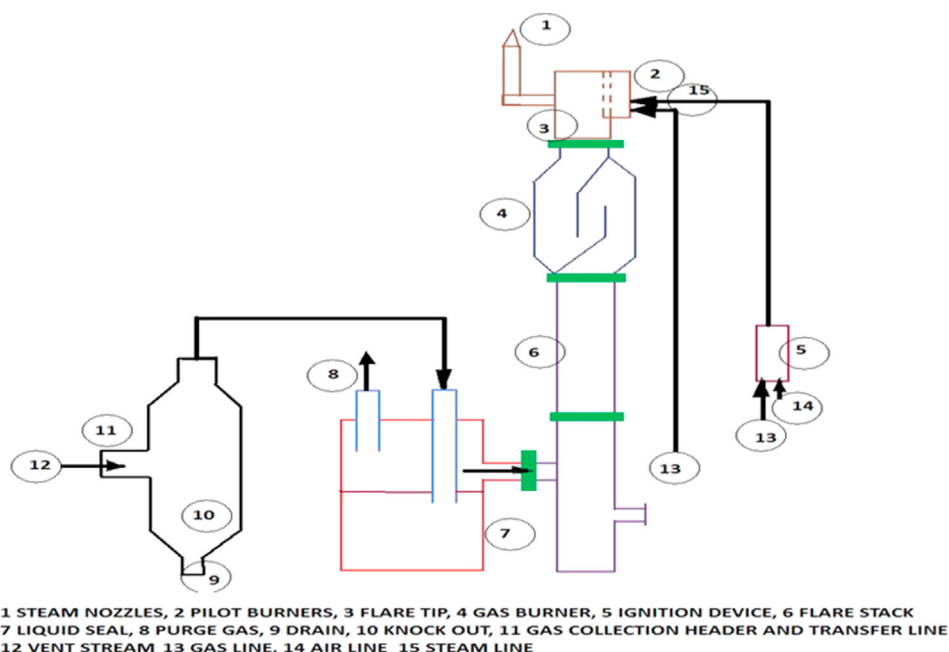

Figure 2. A typical gas flare.

Table 1. Top ten gas flaring countries in 2018.

Country	Volume of Gas Flared (Billion Cubit Feet)
Russia	21.3
Iraq	17.8
Iran	17.3
United States	14.1
Algeria	9.0
Venezuela	8.2
Nigeria	7.4
Lybia	4.7
Mexico	3.9
Angola	3.8

Source: PWC (2019).

than 90 million metric tons of CO₂ on annual basis (Odewale et al., 2017).

3.3. Transportation system

The transport sector accounted for 18.4% of the total emissions in the energy sector in year 2000 (NCC, 2014). The transportation system in Nigeria has grown tremendously over the years as evidenced by the astronomical increase in the number of private and commercial vehicle owners. According to the National Bureau of Statistics report, the number of registered cars on Nigerian road increased from 11.6 million to 11.8 million between fourth quarter of 2017 and that of 2018 (NBS, 2019). The same report confirmed that about 630,868 additional drivers' licenses were issued in 2018. These vehicles run on fossil fuels (gasoline and diesel) which are believed to play leading roles in emission of criteria air pollutants worldwide. Road transport accounts for over 90 percent of total consumption of petroleum products in Nigeria (Croitoru et al., 2020). While there are no documentation of yearly anthropogenic air emissions from transportation sector in the country, quite a lot of traffic related pollution researches have been conducted in different parts of the country and inferences from these reports confirmed Nigeria's transportation systems as prominent drivers of anthropogenic emission (Odekanle et al., 2017; Odunlami et al., 2018; Odogun and Georgakis, 2018; Fakinle et al., 2020).

Nigeria's transportation system has some peculiarities which appear to reinforce its place as a major driver of anthropogenic air emissions among other sources in the country. Quite a large percentage of the vehicles on Nigerian roads are imported in fairly used condition (more than 15 years of use) (Croitoru et al., 2020). Aliyu et al. (2019) also reported that there is a general rise in number of used or poorly maintained vehicles in Nigeria which are believed to be aggravating the level of air pollutants. The catalyst beds in the exhaust of most vehicles designed to act as end of pipe treatment for pollutants in most cases no longer function. In addition, although, the country has huge deposit of crude oil with very low sulfur contents (Faruq et al., 2012; Okedere et al., 2017a); the local refineries do not function as expected; hence, bulk of the premium motor spirit (gasoline) and diesel (automotive gas oil) used in the country are imported. The atmospheric loading of pollutants such as SO_x and some heavy metals have been hinged on the consumption of these imported petroleum products (Jimoda et al., 2014; Olatunji et al., 2015; Okedere et al., 2017a). The sulfur contents in some of the imported fuel were reported to be as high as 1000–3000 ppm as against about 10 ppm in most EU countries (European Council, 2009; George, 2018). Cars and light trucks which constitute the backbone of commuter transportation in the country were reported to contribute about 28,619.03 greenhouse gases in CO₂ equivalents (BURI, 2018). Based on emission inventory of refined petroleum products, about 7.30 X 10⁸ tCO₂e of greenhouse gases were reported to have been contributed by consumption of gasoline and diesel between 1980 and 2014 (Giwa et al., 2017).

Another prominent reason is the deployment of several heavy duty haulage vehicles that run on diesel as the near absolute means of transporting industrial raw materials and finished goods, petroleum and agricultural products across the country. The volumes of the haulage vehicles have significantly increased due to the complete collapse of the rail transportation system over so many decades (Fakinle et al., 2013). Scenes of so many unregulated haulage vehicle parks are common experiences along the roads of major cities in Nigeria. The contributions of heavy duty haulage trucks to ambient levels of particulates in Ogere Park, Ogun State was reported to be highly significant with toxicity potentials above one in many instances (Fakinle et al., 2013). Heavy duty trucks are believed to contribute about 3,394.85 CO₂ equivalents of greenhouse gases (BURI, 2018). Although, there is a current effort to bring back the rail transportation system but as at 2020, it is not yet fully operational.

The proliferation of motorcycle (popularly called Okada) as a means of transportation is another peculiarity of the Nigerian transportation industry. According to the Chairman of Commercial Motorcycle and Tricycle Riders Association, there were about 8 Million registered commercial motorcycle riders in Nigeria as at 2014 (Premium Times, 2014). The consumption of fossil fuel in the transportation industry is therefore not limited to commercial buses, private car owners and haulage trucks. The huge numbers of commercial motorcycles in the country which operate on daily basis run on gasoline and are therefore a force to consider in anthropogenic sources of air pollutants. According to BURI (2018), motorcycles contribute about 2,308.67 CO₂ equivalents of greenhouse gases representing about 6.7% of the total greenhouse gas emissions from road transportation system. In all, the entire transportation system including domestic aviation, rail system, inland water transportation and the earlier mentioned road transportation were reported to contribute 36,022.35 CO₂ equivalents to anthropogenic emission of GHGs in Nigeria (BURI, 2018).

Upstream control of fuel quality is one of the recommended mitigation strategies to address air emissions associated with fuel. For instance, fuel with lower sulphur content will reduce SO₂ emission. Although, effort has been made in this direction through the Nigeria Industrial Standards for fuels which were reviewed in 2017, approval and implementation are still on hold. The document puts maximum fuel sulphur contents at 50 ppm, 150 ppm and 150 ppm for diesel, gasoline and kerosene respectively (Croitoru et al., 2020). A shift to modern automobiles capable of use compressed natural gas is another route to the usage of cleaner fuels. There are now automobiles capable of using electricity. The use of leaner fleet of vehicles will also go a long way in ameliorating traffic related pollutions. The age of cars on Nigeria roads has to be reviewed. Promoting the importation of low emitting vehicles especially those with Euro Standard Emission Control Technology through tax incentives could help. Vehicle inspection and emission testing programme could be strengthened to achieve better results. Other approaches include a general shift to usage of public vehicles to reduce the number of private vehicles on the road just like the Bus Rapid Transit in Lagos (Okokon et al., 2018).

3.4. Manufacturing and telecommunication industries

Manufacturing industries in Nigeria usually contribute to air pollution levels either from power utilities or directly from the manufacturing processes. Due to non reliability of electric power from the grid, all manufacturing industries run on low pour fuel oil (LPFO) generators. Also, the need to heat up processes makes boilers essential feature of manufacturing industry. These energy utilities constitute the bulk of stationary sources of air emissions from manufacturing industries in Nigeria. Key manufacturing industries which are believed to emit significant levels of pollutants include the cement, steel meting and recycling, drugs, soap, detergents among others. There are presently no holistic data on the contributions of manufacturing industries to anthropogenic air emissions in the country; however, several private studies abound but are neither systemized nor continuous. Quite a larger

percentage of the studies have also concentrated on cement industries. For instance, up to 56,100 g/m³ and 12,320 g/m³ concentrations of particulate were reported to have been measured in the neighborhoods of cement and steel melting factories respectively (Adejumo et al., 2004; Asubiojo, 2016). Report by Oguntoke et al. (2012) also confirmed that the concentrations of PM measured around some cement factories exceeded the permissible limits. A recent study on the inventory of cement kiln stack emissions in Southwest Nigeria reported annual levels of NO_x, SO_x, CO₂ and CO as 4.86 tons, 18.2 tons, 2.270 ktons, and 1.17 tons, respectively (Giwa et al., 2019b). Uncontrolled annual emissions from existing cement factories were estimated to be 1,604, 201 tons, 1,495 ton, 78,651.31 tons, 4,218.32 tons and 1,294.5 for PM, CO, SO₂, NO_x and Pb, respectively. These are expected to increase with the addition of proposed cement factories (Oki et al., 2019). On a general note, the availability of emission inventories of air pollutants from other manufacturing industries could provide holistic understanding of their contributions to the country's airshed; although, a World Bank report put their 2007 value as 1.5 MMtCO₂, 1.4 SO₂kt, 29.3 ktNO_x, 0.8 ktBC and 0.9 ktOC per annum (World Bank, 2014).

Another sector that is of serious concern in terms of anthropogenic air emissions is the telecommunication industry (Okedere et al., 2018). Telecommunication industries in Nigeria make use of a mix of on-grid and off-grid power sources (World Bank, 2014). As at 2012, there were 12,560 and 11,692 diesel electric power generators at on-grid and off-grid telecommunication base transceiver stations (BTS) respectively. The average monthly fuel consumption per site was put at 1500 and 1700 L for on-grid and off-grid sites respectively. World Bank report put their 2012 value as 1.3 MMtCO₂, 1.2 SO₂kt, 30.3 ktNO_x, 1.2 ktBC and 0.6 ktOC per annum. A more recent report on emission inventory of back-up generators (BUGs) at BTS revealed that annual levels of NO_x, CO, SO₂, PM₁₀, PM_{2.5}, PAH and TVOC could be as high as 46,542.00–1.22 × 10⁵; 20,685.34–52,671.53; 21.98–55.24; 3,296.73–8,350.36; 3,232.08–8,350.36; 3.10 × 10⁻⁴–7.71 × 10⁻⁴ and 6,852.02–17,985.4 tonnes respectively (Adeniran et al., 2017). The deployment of several thousands of diesel generators are clearly avoidable if power supply from the national grid is reliable. As its name implies, a diesel generator is supposed to be used as a back-up during occasional loss of power from the national grid. However, the non reliability of on-grid power in the country and outright absence in most remote areas have resulted in to heavy reliance on BUGs with grave consequences on levels of air emissions.

Proposed mitigation measure is similar to the one adopted by Egyptian government and financed by World Bank. This involves the use of Best Available Technology (BAT) in the management of industrial emissions. In this approach specific industries (Cement, power generation, steel, petroleum etc) which are known heavy emitters of pollutants will be targeted and specific pollution abatement or control technology will be implemented (World Bank, 2015).

3.5. Small and medium enterprises (SMEs) and completely informal sectors

The term small and medium size enterprises are used to describe enterprises that are very small in terms of number of employees, annual turnover and gross asset. In Nigeria, a small size industry is regarded as one with installed fixed capacity below 5 Million Naira. These types of enterprises help to spur economic growth through reliance on local raw materials to produce goods. Most importantly, SMEs serve as means of reducing rural-urban migration by providing employments and means of livelihood for Nigeria's teeming population. These industries are closer to the grass root and local market thereby providing links between rural areas and large scale urban manufacturing industries. An information captured by Thisday Newspaper on July 20, 2012 showed that of 17.28 million SMEs in the country, 17.26 million could be categorized as very small (micro enterprises) with capacity well below 5 million naira (Sridhar et al., 2018). Sridhar et al. (2018) also reported that most waste

generated by SMEs were disposed via open dumps, open landfills or onsite burning giving rise to air pollution concerns. A major SME in Nigeria is the saw milling industry. According to Okedere et al. (2017b), above 96% of the wood wastes from sawmills are disposed via open burning with serious air pollution consequences.

Apart from registered SMEs, Nigeria economy thrives largely on informal sectors that may not have visibility to the government or its regulatory agencies. These categories include salons, welding shops, cow butchers, grinding mill operators, fashion designers, etc. The non-reliability of electric power from the national grid makes these enterprises to run on varying sizes of gasoline or diesel powered generators. The on-grid power in Nigeria is not adequate to meet the needs of the country. The huge population and economy of Nigeria are instead largely powered with electricity from small-scale generators (World Bank, 2019). Gasoline and diesel electric power generators are frequent sources of localized anthropogenic air emission in Nigeria (World Bank 2014).

The small gasoline generator market is believed to be in about 22 million in 2018 and is projected to increase to 30 million by 2030 (Oseni, 2016; Adeniran et al., 2017; Dalberg, 2019). Dalberg (2019) also reported that about \$12 billion was expended on importation, fuelling, repair and maintenance of generators in 2018. The numbers of small gasoline generators captured by Dalberg must have included those utilized for residential apartments. The use of diesel power generators in Nigeria has great negative impacts on the work environment in terms of noise, air pollution and contribution to climate change due to CO₂ emissions (World Bank, 2019). While the overall contributions of SMEs to atmospheric loads of pollutants may be difficult to estimate because of their predominantly informal nature; the huge numbers suggest that their contributions will be significant and will also impact indoor environments considering that majority are used in close proximity with residential apartments. Reports from individual researchers showed that gasoline and diesel generators emissions may be above permissible limits depending on age and frequency of maintenance (Giwa et al., 2018). Recent study by Giwa et al. (2019c) found out that average emission levels of CO₂, CO and PM_{2.5} from small gasoline generators could be as high as 710 ± 19.1 ppm, 83 ± 4.0 ppm and 83 ± 4.1 µg/m³ respectively. There is a need to conduct more inventory studies on air pollution from the use of small gasoline generators by very small enterprises in Nigeria due to the informal nature of operation. This position is supported by Giwa et al. (2019c) and World Bank (2019), who reported dearth of information in open domain on emission levels and adverse health effects of emissions on small gasoline generators from informal SMEs in Nigeria.

3.6. Medical wastes incineration

Medical wastes are wastes from medical and healthcare facilities whether for humans or animals and may arise from consulting rooms, wards, surgical theaters, laboratories and other investigation units. Their compositions vary markedly and could be categorized as sharps (needles, surgical knives, scissors, wires, broken glass etc), infectious (cultures, vomits, tissues, swabs, excreta etc), radioactive (liquids, glassware and other wastes from radiotherapy and research units), pathological (tissues and contaminated animal or human body parts, fluids and bloods), pharmaceutical (exhausted and expired vaccines and drugs including ointments, tablets and injections), chemicals (batteries, heavy metal from damaged and discarded electronic instruments and mercury of broken thermometers) and genotoxic (cytotoxic mutagenic, carcinogenic drugs) and non-regulated wastes that generally regarded as non-hazardous (Shareefdeen, 2012).

The disposal of medical wastes is given serious attention and regulations in most advanced nations of the world due to their hazardous nature (Coker et al., 2000). While incineration is still in use, some components of the medical wastes may produce other toxic pollutants if the right incineration conditions are not present. Majority of the privately owned hospitals in Nigeria do not have incinerators and possibly disposed their wastes by open burning (Coker et al., 2000). Most tertiary

health facilities such as teaching hospitals however have locally fabricated incinerators (Coker et al., 2000; Adesina et al., 2017, 2018). The effectiveness of these incinerators in handling air pollutants emanating from the incineration of the medical wastes is however doubtful. Coker et al. (2000) reported that the University College Hospital, Nigeria's premier tertiary health facility made use of locally fabricated earth incinerator to handle over 300 kg of medical wastes on daily basis. The facility was noted to be grossly inadequate in terms of size and efficiency of air pollution reduction. Emissions such as PM, SO_x, NO_x, CO, toxic metal, pathogens were reported to be possible from such facilities.

Adesina et al. (2018) investigated the emission of particle bound PAHs from Obafemi Awolowo University Teaching Hospital waste incinerator. In that study, the source emission measurement was achieved by iso-kinetic sampling while the ambient measurement was determined with the aid of a passive sampler loaded with polyurethane foam. Their results showed that significant levels of particulates and PAHs arising from the incinerator were still present in the air. Oyekale and Oyekale (2017) investigated the compliance level of health care waste management facilities in some Nigeria States and reported low level of compliance with standard health care waste management.

According to the 2005 health facilities census by the Federal Ministry of Health, there were slightly above 23,000 public and privately owned hospitals in Nigeria. Although, the accuracy of this figure cannot be ascertained as there were other reports in 2014 that indicated that the 2005 health care facilities census was grossly under estimated considering the fact that so many privately owned hospitals were not captured (Pharm Access Foundation, 2015). One thing is however certain from available report, the numbers of health care facilities have markedly increased and considering the complete absence or inefficient operation of incinerators where available, the incineration of medical wastes is considered a key driver of anthropogenic air emissions in Nigeria. Presently, a systemized inventory of anthropogenic air emissions from hospital wastes incineration is not available in the country.

3.7. Domestic cooking

Combustion of fuels from domestic cooking is another vital contributor to atmospheric levels of air pollutants in Nigeria. Common domestic cooking fuels in Nigeria are fuel-woods, sawdust, charcoal, kerosene and liquefied petroleum gas (LPG) (Fakinle et al., 2017; Ozoh et al., 2018; Giwa et al., 2019d). In Lagos alone, Fakinle et al. (2020) reported an estimated fuel-wood usage of about 1,707,634,110 kg for year 2017. Combustion of biomass has been reported to emit wide varieties of pollutant mostly PM, CO, NO_x, and PAHs with serious adverse human health implications and mortality (Taylor, 2010; Johnston et al., 2019). Smith et al. (2005), reported that even with low emitting biomass, the emission of PM was still 25 times more than when the fuel was LPG. Indoor air emission studies carried out by Ubuoh and Nwajobi (2018) revealed that fuel-woods emitted more CO, PM_{2.5}, NO₂ and SO₂ than most other fuels. The availability of recent data on total atmospheric levels of these pollutants and their source apportionments in the country is doubtful, but domestic cooking with fuel-woods was believed to have contributed to 21.3% of the 2.75×10^9 kg total atmospheric loading of PM in the country (Akeredolu, 1989). Apart from fuel-woods, kerosene is another major domestic cooking fuel in Nigeria. Fakinle et al. (2020) reported that the anthropogenic emissions of PM₁₀, SO₂, CO and NO_x from utilization of kerosene as domestic cooking fuel in Lagos alone grew by 12.8% each between 2009 and 2014.

Although, current trends show that there is gradual migration to LPG in urban centers. According to information credited to the Executive Secretary, Petroleum Product Pricing Regulatory Agency (PPPRA), the per capita consumption of LPG grew by about 144% between 2015 and 2019 (The Guardian, 2019). The domestic consumption of LPG in 2018 of about 600,000 metric tons served a total of 1.5 million households representing 5% of the entire households in the country. A further increase of about 66.7% was witnessed in 2019 with a total LPG consumption of 1

million metric tons while the projection for 2020 is put at 2 million metric tons (Nigeria LPG Summit, 2019). While migration to LPG has the potentials to drastically reduce anthropogenic air emissions from domestic cooking being a cleaner fuel than biomass and kerosene, the projected consumption for 2020 would only serve a meager 5 million households (16.7%). Giving the current population of the country, it can be deduced that, in vast majority of the households, fuel-woods and other less clean fuels are still predominantly being used as domestic cooking fuels. Domestic cooking is therefore considered as a leading driver of anthropogenic air pollutants in the country for which sustained system based emission inventory should be given consideration. Among the measures that could help mitigate the emissions of air pollutants from domestic cooking is a shift to cleaner fuel and the use of efficient biomass and charcoal stoves. The Nigerian government has been making effort to deepen the domestic LPG penetration.

3.8. Municipal waste disposal

As far back as 1989, report has shown that burning of municipal wastes would be a major player in the emission of anthropogenic air pollutants in Nigeria. In a report by Akeredolu (1989), the estimated annual total atmospheric loading of PM in the country was put at 2.75×10^9 kg with municipal wastes believed to have contributed 2.1% of the estimated figure. Even in Lagos State which appears to have a semblance of municipal waste management, dependence on open dumpsites is still very heavy; illegal dumpsites and open burning are still pretty much the practice (LAWMA, 2016; Croitoru et al., 2020). Fakinle et al. (2020) identified burning of solid wastes as the most significant factor contributing to anthropogenic air emission in Lagos. Okedere et al. (2019) had earlier reported that municipal wastes in majority of Nigerian States are disposed in open dumpsites and burnt openly.

The population growth of the country has translated to rapid increase in municipal waste generation. About 1.7 million metric tons of municipal wastes were collected in Lagos only in 2016 (LAWMA, 2016; Croitoru et al., 2020) although Bioenergy Consult estimated municipal wastes from Lagos to be about 3.6 million tons per annum (BioEnergy Consult, 2020). The annual output of municipal wastes in the entire country was estimated to be around 25 million tons in 2009 (Ogwueleka, 2009); and this is believed to have increased to about 32 million metric tons with roughly a quarter being collected or accounted for (BioEnergy Consult, 2020). There are hardly budgetary provisions for integrated solid wastes management hence bulk of these wastes end in open dumpsites and subsequently burnt; hence, contributing to anthropogenic loadings of air pollutants. Municipal wastes are usually composed of wide varieties of substances; hence, emission of wide varieties of pollutants with adverse human health effects (Okedere et al., 2019). To address this, an efficient waste management system which is currently missing in almost all the federating States of Nigeria has to be evolved. This involves collection of wastes at the source, transportation, sorting and segregation, recycling, waste to energy conversion, landfills or incineration. Public enlightenment is also a key aspect of municipal solid waste management as it helps to promote reuse and reduction of wastes from the source.

3.9. Bush burning, land use and agriculture

During dry season, scenes of indiscriminate burning of vegetation, grasslands and forests are common sights in Nigeria (Ambe et al., 2015). Nigeria is reported to be among the top 13 countries where bush burning is prevalent (Asubiojo, 2016; Izah et al., 2017). Prominent reasons adduced to the practice by practitioners are hunting for animals, clearing of farmlands for planting purposes, soil fertility improvement, facilitation of rapid growth of new pastures for nomadic farming (Jamala et al., 2012; Ambe et al., 2015). Bush burning emits varieties of air pollution which could include CO, CO₂, PM, NO_x, SO₂, VOCs, PAHs (Fakinle et al., 2017; Izah et al., 2017; Okedere et al., 2017b). There are no recent data documenting the contributions of bush burning to anthropogenic air

emissions in Nigeria. However, [Akeredolu \(1989\)](#) reported that up to 31.7% of annual PM (2.75×10^9 kg) was due to bush burning. This practice is still very prevalent in Nigeria and is considered a key driver of air pollution in the country. Advocacies and public awareness is the major step needed to address indiscriminate burning of bushes.

Changes in land use pattern and forest handling practices contribute immensely to the net emissions of GHGs, most importantly CO₂. Being an agrarian country, agricultural practices in Nigeria interfere with vegetation and soil carbon from time to time. Aside farming, urbanization and expansion of cities are also affecting land use pattern in the form of extensive deforestation, de-vegetation and building of structures and infrastructures. According to Nigeria's National Communication on Climate (NCC) report, the government is addressing emissions in this sector through its forestry programmes of afforestation, agro forestry and forest protection (NCC, 2003; [NCC, 2014](#)).

The agricultural sector also contributes significantly to anthropogenic GHGs via oxidation of biomass and organic matter. Soils contain high levels of soil organic matter and agricultural practices release CO₂ from the breakdown of this soil organic matter. Also, in an attempt to mechanize farming activities, farm machineries are deployed leading to combustion of fossil fuel with the attendant air pollutants. Rice cultivation and animal rearing are essential agricultural activities in Nigeria but they are associated with release of air pollutants (NCC, 2011; NCC, 2012). Recommended mitigation strategies in rice cultivation include nutrient improvement through the use of organic fertilizers, zero-or minimum-tillage, improved fallows, crop rotation and retention of residues on the soil surface to replenish soil organic matter ([NCC, 2014](#)). Some of the existing air pollution inventories for criteria air pollutants and GHGs are summarized in [Table 2](#) and [Figure 3](#), respectively. From [Table 2](#), while the cumulative amount of gas flared is still very high, there has been a reduction in percentage of gas being flared. [Giwa et al. \(2019a\)](#) reported different cycles of flared volume and gaseous emissions over that past five decades. Presently, a reduction in flared volume and emissions were reported from 2007 to 2015 ([Giwa et al., 2019a](#)). Notwithstanding, the air quality indices associated with criteria air pollutants emissions from gas flaring were generally above safe limits indicating that the emitted concentrations are still considerably high ([Giwa et al., 2019a](#)). [Table 2](#) also shows some inventories of criteria air pollutants from petroleum refining, thermal plants and cement production. Additional thermal plants and petroleum refineries are in progress; anthropogenic emissions from these activities are expected as new plants come on stream.

4. Epidemiology and other adverse effects of air pollution in Nigeria

Several epidemiological studies involving Nigerian petroleum industries have established a link between exposure to various anthropogenic emissions and varying degrees of health risks. [Olowoporoku et al. \(2012\)](#) reported difference in disease susceptibility among people living in areas prone to air pollution exposure and those that did not live in such areas. [Nriagu et al. \(2016\)](#) examined the health risks associated with oil

pollution in the Niger Delta region of Nigeria in its elementary form. Their reports showed psychological and emotional stress such as anger, annoyance and fear as part of the experiences of the people of the region. [Ana et al. \(2009\)](#) reported more aggravated health risks such as painful body outgrowths, skin disorders, respiratory disorders and morbidities as well child deformities as part of their petroleum industry related epidemiological studies in Nigeria. [Nwachukwu et al. \(2012\)](#) surveyed the interrelation between air pollutants and diseases and found out that tuberculosis, pneumonia, upper respiratory diseases which were experienced by a test group in Rivers State were associated exposure to air pollution. Prolonged exposure to gas flares had impact on elevated blood pressure and increased the risks of hypertension and circulatory diseases ([Egwurugwu, and Nwafor, 2013](#)).

Exposure to anthropogenic emissions from energy generation utilities such as thermal plants, diesel and gasoline generators have also been reported to have detrimental effects on human health. Health impacts assessment of emissions revealed unhealthy levels of CO and PM_{2.5} around gasoline powered generators in a study conducted by [Giwa et al. \(2019a,b,c,d\)](#). [Awofeso \(2011\)](#) found association between incidences of asthma and lung cancer among people who use diesel electric power generators in Nigeria. Several cases of hospital admission due to exposure to elevated CO from generators have been experienced in Nigeria. Among experiences associated with inhalation of CO are breathlessness, restlessness and unconsciousness, convulsion, sphincter incontinence, foaming in the mouth and death ([Seleye- Fubara et al., 2010](#); [Afolayan et al., 2014](#)).

Studies on levels of air pollutants from transportation and traffic related activities abound in Nigeria ([Ogunsola et al., 1994](#); [Adepoju et al., 2018](#)). Traffic pollution usually poses serious adverse effect on ambient and outdoor air quality. [Aliyu and Botai \(2018\)](#) reported incidences of respiratory problems in Zaria in about 6.7% of people exposed to outdoor concentrations of air pollutants beyond permissible limit. [Croitoru et al. \(2020\)](#), in a World Bank document on the cost of air pollution in Lagos reported that air pollution related morbidity and mortality are most prevalent in Lagos than most other African cities. [Fakinle et al. \(2013\)](#) reported that toxicity potentials of particulates around haulage vehicle parks were unhealthy. Elevated in-vehicle levels of pollutants have also been reported by [Odekanle et al. \(2014\)](#). [Mustapha et al. \(2011\)](#) reported associations between traffic pollution and wheezing, night cough and phlegm.

Ophthalmological survey to determine ocular health among industrial workers was carried out by [Okoye and Umeh \(2002\)](#). The industries investigated were cement, coal mines, saw mills, and iron and steel works and report revealed that eye injuries were associated with cement dust, coal dust, wood pieces, sawdust and metal chips. Prominent among the type of eye injuries were contusions. Exposure to cement dust has also been reported to affect lung and respiratory functions in a study by [Merenu et al. \(2007\)](#) and ([Chukwu and Uboji, 2016](#)). Reported impacts of cement dust among factory workers include wheezing, sneezing, coughing, breathlessness and other chest illnesses. Apart from the actual manufacturing processes, power utilities in the manufacturing industries such as boilers and diesel generators emit PM and soot. Anthropogenic

Table 2. Some criteria air pollution emission inventories.

Sector	CO	NOx	PM	SO ₂	VOC	Pb	Source
Thermal Plants (ton/annum)	84,568.50	141,417.40	3,271.10	1,574.20	981.90		Sonibare (2010)
Thermal Plants (ton/annum)	74042.84	121403.82	2783.64	1473.84	892.49		Adesanmi et al. (2015)
Petroleum Refining (ton/annum)					147,212		Sonibare et al. (2007)
Petroleum Refining (ton/annum)	242,469	167,570	1217(PM ₁₀)	45,124			Oladimeji et al. (2015a,b)
Gas Flaring (ton/annum)	548			1.16			Sonibare and Akeredolu (2004)
Gas Flaring (ton/annum)	5400	27000	2700	160			Akeredolu (1989)
Cement Industry (ton/annum)	1495.7	44218.3	1604637.4	78651.3		1,213.80	Oki et al. (2019)
Nigeria (ton/annum)			2750000				Akeredolu (1989)

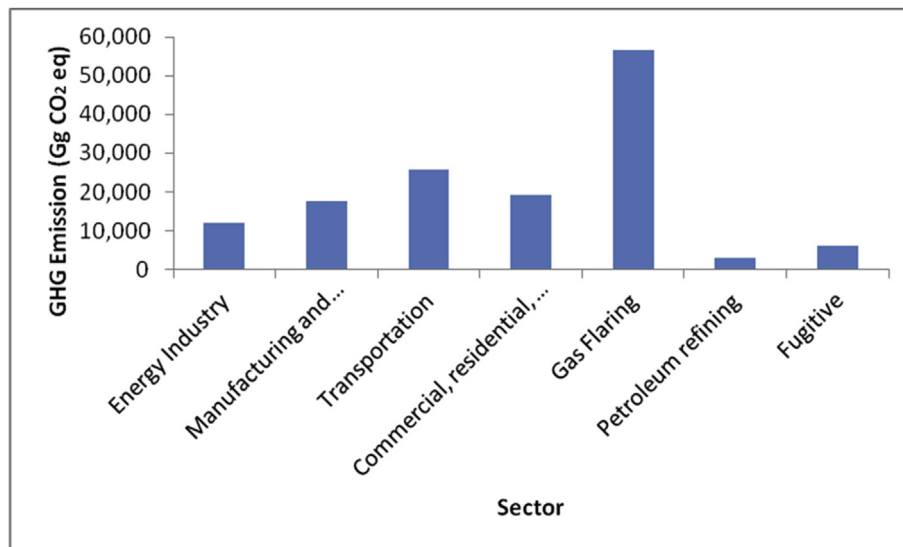

Figure 3. Emission inventory of GHGs for year 2000.

air pollution by SMEs in Nigeria are generally traceable to small gasoline generators. Hence, epidemiological impacts are similar to those reported for power utilities.

Apart human health issues, other reported adverse effects include acid rain with its attendant effects on vegetations and structures. [Nduka et al. \(2008\)](#) reported acidity differential between rain water collected from oil producing and non-oil producing communities in Nigeria. [Oghenejoboh \(2016\)](#) reported effects of acid rain and other pollutants on the socio-economic life of people in communities hosting gas flares. Specifically, crop yield, quality of portable water, aquatic life and eco-system were reported to be adversely affected. Increase in atmospheric levels of heavy metals has been reported around cement plants in some atmospheric deposition studies with possible bioaccumulation in plants and subsequent transfer to humans and animals ([Ogunkunle and Fatoba, 2014](#)).

5. Recommended management

In order to appropriately respond to the rising levels of anthropogenic air emissions from the various sources in Nigeria; there is the need to first profile new anthropogenic emissions sources that are not already captured in the available inventory with a view to quantifying their contributions on continuous basis. Also, the existing emission inventory should be updated and reported for the identified sources of key air pollutants on regular basis (yearly). Emission inventory involves quantifying the levels of activities from sources that have been identified as drivers of air pollutant with a view to quantifying the emission rates of each air pollutant from such activities. Emission inventory approach has been used successfully by the US EPA and many other researchers have adopted it ([US EPA, 1995](#); [Sonibare et al., 2007](#); [Sonibare, 2010](#); [Jain et al., 2016](#); [Giwa et al., 2017](#); [Okedere et al., 2017a](#); [Okedere et al., 2018](#); [Giwa et al., 2019a](#); [Fakinle et al., 2020](#)). The use of emission factor is central in emission inventory computation as shown in [Eq. \(14\)](#).

$$\text{Rate} \left(\frac{\text{tons}}{\text{year}} \right) = AB \left(\frac{100 - P}{100} \right) \quad (14)$$

where:

- A = Annual operating rate or source activity;
- B = Emission factor (kg/unit)
- P = Percentage control or efficiency (%)

In the United States, an agency of government like the United States Environmental Protection Agency is in charge of profiling, advising and developing means of mitigating these emissions. Quite a number of emission reduction programme are being implemented by developed nation of the world. For instance, there has been reduction in SO₂ emissions owing to implementation of very strict emission limits imposed on factories in the US, Europe and China ([Klimont et al., 2013](#)). Some Asian and almost all African countries especially Nigeria are still very much behind in profiling and mitigation of anthropogenic air pollutants. In Nigeria, an Agency of government like National Environmental Standards and Regulatory Agency (NESREA) can be saddled with the responsibility of driving and coordinating of continuous and holistic research in this direction as against studies driven by individual researchers. This will assist to develop national inventory data pool that will aid planning for mitigation.

6. Conclusion

A review of anthropogenic air pollution drivers in Nigeria has been conducted. Evidences point to multiplicity of sources of these air emissions. The atmospheric levels of these pollutants are on the increase due to myriads of uncontrolled emission sources. All pollution sources in the country were observed to revolve around some major drivers which are energy production, transportation, wastes management, land use and agricultural practices. The available emission inventories are inadequate and absence of continuous updating of the emission inventories on yearly basis affects the mitigation and management plans. For instance, a holistic contribution of each of the reviewed sources to atmospheric loading of anthropogenic air emissions cannot be ascertained for each year at any given time due to the absence of a deliberate systemic and continuous monitoring of pollutants from the identified sources. Consequently, the inadequacy of existing national inventory of anthropogenic emissions implies that there is no continuous pool of data for national planning. Going forward, the scope of a government agency like National Environmental Standards and Regulation Enforcement Agency (NESREA) may have to be expanded to involve coordination of active and continuous researches into monitoring, compilation of inventory and development of mitigation and management strategies for anthropogenic emission sources in the country. The energy policy of the country should be reviewed for a possible shift to cleaner forms of energy as against the current drive for more thermal plants. Other alternatives that could be considered are the solar and wind energy sources which have been

reported to have potentials in the country. Also, a serious campaign and policy drive as well as adoption of modern integrated solid waste management will significantly assist to ameliorate the atmospheric levels of anthropogenic air emissions in the country.

Declarations

Author contribution statement

All authors listed have significantly contributed to the investigation, development and writing of this article.

Funding statement

This research did not receive any specific grant from funding agencies in the public, commercial, or not-for-profit sectors.

Data availability statement

The data that has been used is confidential.

Declaration of interests statement

The authors declare no conflict of interest.

Additional information

No additional information is available for this paper.

Acknowledgements

The authors of this article are grateful to the Management of Covenant University, Nigeria for the payment of the article publishing charge.

References

- Abdel-Shafy, H.I., Mansour, M.S.M., 2016. A review on polycyclic aromatic hydrocarbons: source, environmental impact, effect on human health and remediation. *Egypt. J. Petrol.* 25 (1), 107–123.
- Adejumo, et al., 2004. Air pollution studies in some Nigerian industries. In: Oluwole, A.F., Asubiojo, O.I., Obioh, I.B., Ogunsola, O.J. (Eds.), *Proceedings of Int. Workshop on Environmental Monitoring and Impact Assessment*, pp. 169–176.
- Adeniran, J.A., Yusuf, R.O., Amole, M.O., Jimoda, L.A., Sonibare, J.A., 2017. "Air quality impact of diesel back-up generators (BUGs) in Nigeria's mobile telecommunication base transceiver stations (BTS). *Manag. Environ. Qual. Int. J.* 28 (5), 723–744.
- Adepoju, T.T., Fakinle, B.S., Adesina, O.A., Okedere, O.B., Sonibare, J.A., 2018. Estimation of gaseous criteria air pollutants from road transport system in Lagos metropolis of Nigeria. *Environ. Qual. Manag.* 27 (4), 155–162.
- Adesanmi, A.J., Badmos, S.A., Gbadebo, O.A., Sonibare, J.A., 2015. Emission inventory of electricity generation from thermal plants in Nigeria. *Global Sci. J.* 7 (2), 140–149.
- Adesina, O.A., Sonibare, J.A., Diagboya, P.N., Adejuwon, A., Famubode, T., Bello, J.O., 2017. Periodic characterization of alkyl-naphthalenes in stack gas and ambient air around a medical waste. *Environ. Sci. Pollut. Control Ser.* 24 (27), 21770–21777.
- Adeyanju, E., Okeke, C.A., 2019. Exposure effect to cement dust pollution: a mini review. *SN Appl. Sci.* 1, 1572.
- Afolayan, J.M., Edomwonyi, N.P., Esangbedo, S.E., 2014. Carbon monoxide poisoning in a Nigerian home: case reports. *Niger. Postgrad. Med. J.* 21 (2), 199–202.
- Agboola, O.M., Nwulu, N., Egelioglu, F., Agboola, P., 2020. Gas flaring in Nigeria: Opportunity for household cooking utilization. *Int. J. Therm. Environ. Eng.* 2 (2).
- Akeredolu, F., 1989. Atmospheric environment problems in Nigeria - an overview. *Atmos. Environ.* 23 (4), 783–792.
- Akeredolu, F.A., Sonibare, J.A., 2004. A review of the usefulness of gas flares in air pollution control. *Manag. Environ. Qual. Int. J.* 15 (6), 574–583.
- Al-Hasnawi, S.S., Hussain, H.M., Al-Ansari, N., Knutsson, S., 2016. The effect of the industrial activities on air pollution at Baiji and its surrounding areas, Iraq. *Engineering* 8, 34–44.
- Alexander Laskin, A., Laskin, J., Nizkorodov, S.A., 2015. Chemistry of atmospheric Brown carbon. *Chem. Rev.* 115 (10), 4335–4382.
- Aliyu, Y.A., Botai, J.O., 2018. An exposure appraisal of outdoor air pollution on the respiratory well-being of a developing city population. *J. Epidemiol. Global Health* 8 (1–2), 91–100.
- Ambe, B.A., Eja, I.E., Agbor, C.E., 2015. Assessment of the impacts and people's perception of bush burning on the grasslands and montane ecosystems of the Obanliku Hills/Plateau, Cross river state, Nigeria. *J. Nat. Sci. Res.* 5 (6), 12–20.
- Ana, G.R.E.E., Sridhar, M.K.C., Bamgboye, E.A., 2009. Environmental risk factors and health outcomes in selected communities of the Niger delta area, Nigeria. *Perspec. Public Health* 129 (4), 183–191.
- Asubiojo, O.I., 2016. Pollution sources in the Nigerian environment and their health implications. *IFE J. Sci.* 18 (4), 973–980.
- Awofeso, N., 2011. Generator diesel exhaust: a major hazard to health and the environment in Nigeria. *Am. J. Respir. Crit. Care Med.* 183 (10), 1437.
- Balmes, J.R., 2019. Household air pollution from domestic combustion of solid fuels and health. *J. Allergy Clin. Immunol.* 143 (6), 1979–1987.
- Bernabeo, R.A., Webster, K., Onofri, M., 2019. Health and environmental impacts of Nox: an ultra-low level of Nox (oxides of nitrogen) achievable with A new technology. *Global J. Environ. Sci.* 2 (3), 1–6.
- BioEnergy Consult, 2020. Solid Wastes Management in Nigeria. <https://www.bioenergyconsult.com/tag/waste-management-in-lagos/>.
- Bonfanti, L., De Michele, G., Riccardi, J., Lopez-Doriga, E., 1994. Influence of coal type and operating conditions on the formation of incomplete combustion products. *Pilot Plant Exp. Combust. Sci. Technol.* 101 (1–6).
- BUR1, 2018. First Biennial Update Report of the Federal Republic of Nigeria under the United Nations Framework Convention on Climate Change (UNFCCC). [https://www4.unfccc.int/sites/SubmissionsStaging/NationalReports/Documents/218354_Nigeria-BUR1-1-Nigeria%20BUR1_Final%20\(2\).pdf](https://www4.unfccc.int/sites/SubmissionsStaging/NationalReports/Documents/218354_Nigeria-BUR1-1-Nigeria%20BUR1_Final%20(2).pdf).
- CEIC, 2020. Nigeria Electricity Production, 2005 – 2020. <https://www.ceicdata.com/en/indicator/nigeria/electricity-production>.
- Chen, T.L., 2017. Air pollution caused by coal-fired power plant in middle Taiwan. *Int. J. Energy Power Eng.* 6 (6), 121–124.
- Chukwu, M.N., Ubosi, M.N., 2016. Impact of cement dust pollution on respiratory systems of Lafarge cement workers, Ewekoro, Ogun State, Nigeria. *Global J. Pure Appl. Sci.* 22, 1–5.
- Coker, A.O., Akanmu, A.M., Sridhar, M.K.C., Aladeno, I.O., 2000. Management of pollution from an hospital incinerator in Nigeria. In: Brebbia, C.A., Power, H., S Longhurst, J.W. (Eds.), *Air Pollution, VIII*. WIT Press, pp. 253–259. www.witpress.com.
- Comunian, S., Dongo, D., Milani, C., Palestini, P., 2020. Air pollution and COVID-19: the role of particulate matter in the spread and increase of COVID-19's morbidity and mortality. *Int. J. Environ. Res. Publ. Health* 17 (12), 4487.
- Cousin, X., Cachot, J., 2014. PAHs and fish—exposure monitoring and adverse effects—from molecular to individual level. *Environmental Science and Pollution Research. Environ. Sci. Pollut. Control Ser.* 21, 13685–13688.
- Croituru, L., Chang, J.C., Kelly, A., 2020. The Cost of Air Pollution in Lagos. *Pollution Management and Environmental Health. World Bank Group*.
- CSE (Centre for Science and Environment), 2012. Black carbon: a short-lived climate forcer cannot substitute CO₂ mitigation strategies. <https://cdn.cseindia.org/userfiles/Black Carbon 2012.pdf>.
- Dalberg, 2019. Putting an End to Nigeria's Generator Crisis: the Pathway forward. Access to Energy Institute. https://a2ei.org/resources/uploads/2019/06/A2EI_Dalberg_Putting_an_End_to_Nigeria%E2%80%99s_Generator-Crisis_The_Path_Forward.pdf.
- Damian, C., 2013. Environmental pollution in petroleum refining industry. *Ovidius Univ. Ann. Chem.* 24 (2), 109–114.
- Das, S., Raj, R., Mangwani, N., Dash, H.R., Chakraborty, J., 2014. 2 - heavy metals and hydrocarbons: adverse effects and mechanism of toxicity. *Microb. Biodegrad. Bioremediation* 23–54.
- Deng, M., Li, P., Ma, R., Shan, M., Yang, X., 2020. Air pollutant emission factors of solid fuel stoves and estimated emission amounts in rural Beijing. *Environ. Int.* 138.
- Dmichowski, W., Gozdowski, D., Baczewska-Dąbrowska, A.H., Dąbrowski, P.I., Gworek, B., Suwara, I., 2018. Evaluation of the impact of reducing national emissions of SO₂ and metals in Poland on background pollution using a bioindication method. *PLoS One* 13 (2), e0192711.
- Egwurugwu, J.N., Nwafor, A., 2013. Prolonged exposure to oil and gas flares ups the risk for hypertension. *Am. J. Health Res.* 1 (3), 65–72.
- Ejiogu, A.R., 2013. Gas flaring in Nigeria: cost and policy. *Energy Environ.* 24 (6), 983–998.
- Ekpoh, I.J., Obia, A.E., 2010. The role of gas flaring in the rapid corrosion of zinc roofs in the Niger Delta Region of Nigeria. *Environmentalist* 30, 347–352.
- Emberson, L.D., Pleijel, H., Ainsworth, E.A., Berg, M.V.D., Ren, W., Osborne, S., Mills, G., Pandey, D., Dentener, F., Büker, P., Ewert, F., Koeble, R., Dingenen, R.V., 2018. Ozone effects on crops and consideration in crop models. *Eur. J. Agron.* 100, 19–34.
- European Council, 2009. Directive 2009/30/EC of the European Parliament and of the Council.
- Fakinle, B.S., Sonibare, J.A., Akeredolu, F.A., Okedere, O.B., Jimoda, L.A., 2013. Toxicity potential of particulates in the airshed of haulage vehicle park. *GNST* 15 (4), 466–473.
- Fakinle, B.S., Okedere, O.B., Seriki, O., Adesanmi, A.J., Sonibare, J.A., 2017. An estimation of a trace gaseous emission factor from combustion of common fuelwood species in South-western Nigeria. *Energy Sources Part A Recov. Util. Environ. Eff.* 39 (12), 1298–1306.
- Fakinle, B.S., Odekanle, E.L., Olalekan, A.P., Ije, H.E., Oke, D.A., Sonibare, J.A., 2020. Air pollutant emissions by anthropogenic combustion processes in Lagos, Nigeria. *Cogent Eng.* 7 (1), 1808285.
- Faruq, U.Z., Runde, M., Danshehu, B.G., Yahaya, H.N., Zuru, A.A., Muhammad, A.B., 2012. Comparative studies of gasoline samples used in Nigeria. *Nigeria J. Basic Appl. Sci.* 20, 87–92.
- Fridell, E., Steen, E., Peterson, K., 2008. Primary particles in ship emissions. *Atmos. Environ.* 42, 1160–1168.
- George, L., 2018. Nigeria to Cut Sulfur in Fuels a Year after U.N. Deadline. *Reuters*. <https://www.reuters.com/article/us-nigeria-fuels-sulphur/nigeria-to-cut-sulfur-in-fuels-a-year-after-u-n-deadline-idUSKCN1G1PHQ>.

- Giwa, S.O., Sulaiman, M.A., Nwaokocha, C.N., 2017. Inventory of greenhouse gases emissions from gasoline and diesel consumption in Nigeria. *Niger. J. Technol. Dev.* 14 (1), 1–13.
- Giwa, S.O., Nwaokocha, C.N., Adeyemi, H.O., 2018. Noise and emission characterization of off-grid diesel-powered generators in Nigeria. *Manag. Environ. Qual. Int. J.* 30 (4), 783–802.
- Giwa, S.O., Nwaokocha, C.N., Kuye, S.I., Adama, K.O., 2019a. Gas flaring attendant impacts of criteria and particulate pollutants: a case of Niger Delta region of Nigeria. *J. King Saud Univ. Eng. Sci.* 39 (3), 209–217.
- Giwa, S.O., Nwaokocha, C.N., Layeni, A.T., 2019b. Inventory of kiln stacks emissions and health risk assessment: case of a cement industry in Southwest Nigeria. *Afric. J. Sci. Technol. Innov. Dev.* 11 (3), 299–312.
- Giwa, S.O., Nwaokocha, C.N., Samuel, D.O., 2019c. Off-grid gasoline-powered generators: pollutants' footprints and health risk assessment in Nigeria. *Energy Sources Part A Recov. Util. Environ. Effects.*
- Giwa, S.O., Nwaokocha, C.N., Odudufa, B.O., 2019d. Air pollutants characterization of kitchen microenvironments in Southwest Nigeria. *Build. Environ.*
- Guo, W., Pan, B., Sakkiah, S., Yavas, G., Ge, W., Zou, W., Tong, W., Hong, H., 2019. Persistent organic pollutants in food: contamination sources, health effects and detection methods. *Int. J. Environ. Res. Publ. Health* 16, 4361.
- Haridoss, S., 2017. Effect of air pollutants and its emission control strategies in petroleum refineries. *J. Ind. Pollut. Contr.* 33 (1), 1019–1023.
- Iowa Department of Natural Resources (IDNR), 2020. Effects of Ground Level Ozone. <https://www.iowadnr.gov/Environmental-Protection/Air-Quality/Air-Pollutants/Effects-Ozone>.
- Intergovernmental Panel on Climate Change (IPCC), 1997. Revised 1996 IPCC Guidelines for National Greenhouse Gas Inventories. Reference Manual (Revised). In: Houghton, J.T., et al. (Eds.), Vol 3. IPCC/OECD/IEA, Paris, France.
- Izah, S.C., Angaye, T.C.N., Aigberua, A.O., Nduka, J.O., 2017. Uncontrolled bush burning in the Niger Delta region of Nigeria: potential causes and impacts on biodiversity. *Int. J. Mol. Ecol. Conserv.* 7 (1), 1–15.
- Jain, R.K., Cui, P.E.Z.C., Domen, J.K., 2016. Environmental Impact of Mining and Mineral Processing: Management, Monitoring, and Auditing Strategies, pp. 53–157. Chapter 4.
- Jamala, G.Y., Boni, P.G., Abraham, P., Teru, C.P., 2012. Evaluation of environmental and vulnerability impact of bush burning in southern Guinea Savanna of Adamawa state, Nigeria. *Am. J. Exp. Agric.* 2 (3), 359–369.
- Jandacka, D., Durcanska, D., Bujdos, M., 2017. The contribution of road traffic to particulate matter and metals in the air. *Transport. Res. Transport Environ.* 50, 397–408.
- Jimoda, L.A., Olatunji, O.S., Adeniran, J.A., Fakinle, B.S., Sonibare, J.A., 2014. Atmospheric loadings of Lead from refined petroleum products consumption in Southwestern Nigeria. *Petrol. Sci. Technol.* 32 (24), 2921–2929.
- Johnston, H.J., Mueller, W., Steinle, S., Vardoulakis, S., Tantrakarnapa, K., Loh, M., Cherrie, J.W., 2019. How harmful is particulate matter emitted from biomass burning? A Thailand perspective. *Curr. Pollut. Rep.* 5, 353–377.
- Khan, M.R., Khan, M.M., 2011. Plants response to diseases in sulphur dioxide stressed environment. *Plant Pathol. J.* 10, 1–12.
- Kim, H.H., Choi, S., 2018. Therapeutic aspects of carbon monoxide in cardiovascular disease. *Int. J. Mol. Sci.* 19 (8), 2381.
- Klimont, Z., Smith, S.J., Cofala, 2013. The last decade of global anthropogenic sulfur dioxide: 2000–2011 emissions. *Environ. Res. Res. Lett.* 8, 014003.
- Kumar, S., 2017. Acid rain- the major cause of pollution: its causes, effects. *Int. J. Appl. Chem.* 13 (1), 53–58.
- Kurnyina, O.V., Popova, O.V., Zubkova, S.V., Karpukhin, D.V., Pavlov, V.P., Varenik, P.K., Aleshkova, I.A., Novitskaya, L.Y., 2018. Air pollution by road traffic and its measurement methods. *EurAsia J. BioSci.* 12, 181–188.
- Laskar, A.A., Younus, H., 2018. Aldehyde toxicity and metabolism: the role of aldehyde dehydrogenases in detoxification, drug resistance and carcinogenesis. *Drug Metabol. Rev.*
- Lawal, A.T., 2017. Polycyclic aromatic hydrocarbons – a review. *Cogent Environ. Sci.* 3 (1).
- LAWMA, 2016. Lagos Waste Management Authority Has Reported Collection and Disposal of Approximately 1.7 Million Tonnes of Waste in Lagos in 2016, of an Estimated Total Waste Generated of Approximately 4.4 Million in that Same Year. <http://www.lawma.gov.ng/>.
- Li, Q., Song, C., Mao, H., 2019. Particulate Matter and Public Health, second ed. *Encyclopaedia of Environmental Health*, pp. 31–35.
- Lifespan, 2018. Carbon Monoxide May Cause Long-Lasting Heart Damage. *Science News*. <https://www.sciencedaily.com/releases/2008/01/080129125412.htm>.
- Lu, X.C., Yao, T., Li, Y., Fung, J.C.H., Lau, A.K.H., 2016. Source apportionment and health effect of NOx over the Pearl River Delta region in southern China. *Environ. Pollut.* 212, 135–146.
- Medeiros, A.S.S., Calderaro, G., Guimarães, P.C., Magalhaes, M.R., Morais, M.V.B., Rafee, S.A.A., Ribeiro, I.O., Andreoli, R.V., Martins, J.A., Martins, L.D., Martin, S.T., Souza, R.A.F., 2017. Power plant fuel switching and air quality in a tropical, forested environment. *Atmos. Chem. Phys.* 17, 8987–8998.
- Merenu, I.A., Mojiminiyi, F.B.O., Njoku, C.H., Ibrahim, M.T.O., 2007. The effect of chronic cement dust exposure on lung function of cement factory workers in Sokoto. *Nigeria Afri. J. Biomed. Res.* 10, 139–143.
- Muleski, G.E., Cowherd Jr., C., 2005. Particulate emissions from construction activities. *J. Air Waste Manag.* 55, 772–783.
- Mustapha, B.A., Blangiardo, M., Briggs, D.J., Hansell, A.L., 2011. Traffic air pollution and other risk factors for respiratory illness in Schoolchildren in the Niger-delta region of Nigeria. *Environ. Health Perspect.* 119 (10), 1478–1482.
- NBS (Nigeria Bureau of Statistics), 2019. Road industry data. https://www.nigerianstat.gov.ng/pdfuploads/Road_Transport_Data_-_Q4_2018.pdf. (Accessed 15 January 2021).
- NCC, 2014. Nigeria's second national communication under the united nations framework convention on climate change. Federal republic of Nigeria. <https://unfccc.int/sites/default/files/resource/nganc2.pdf>. (Accessed 15 January 2021).
- Nduka, J.K.C., Orisakwe, O.E., Ezenweke, L.O., Ezenwa, T.E., Chendo, M.N., Ezeabasili, N.G., 2008. Acid rain phenomenon in Niger delta region of Nigeria: economic, biodiversity, and public health concern. *Sci. World J.* 8, 811–818.
- NERC, 2008. Nigerian Electricity Regulatory Commission. www.nercng.org.
- Nigeria LPG Summit, 2019. LPG: harmonizing development and growth in Nigeria and Africa- post show report, federal Palace Hotel, Lagos, Nigeria, 26–27th November, 2019. <http://www.lpgsummit.com/wp-content/uploads/2019/12/Nigeria-LPGSummit-PSR-2019-04.compressed.pdf>.
- NPC, 1991. Population Census of the Federal Republic of Nigeria: Analytical Report at the National Level. National Population Commission, Abuja, Nigeria.
- NPC, 2007. 2006 Population Census of the Federal Republic of Nigeria: Analytical Report at the National Level. National Population Commission, Abuja, Nigeria.
- Nriagu, U., Udofia, E.A., Ekong, I., Ebuk, G., 2016. Health risks associated with oil pollution in the Niger delta, Nigeria. *Int. J. Environ. Res. Publ. Health* 13 (3), 346.
- Nwachukwu, A.N., Chukwuocha, E.O., Igbudu, O., 2012. A survey on the effects of air pollution on diseases of the people of Rivers State, Nigeria. *Afr. J. Environ. Sci. Technol.* 6 (10), 371–379.
- Nwankwo, C.N., Ogagarue, D.O., 2011. Effects of gas flaring on surface and ground waters in Delta State Nigeria. *J. Geol. Min. Res.* 3 (5), 131–136.
- Odekanle, E.L., Fakinle, B.S., Jimoda, L.A., Okedere, O.B., Akeredolu, F.A., Sonibare, J.A., 2017. In-vehicle and pedestrian exposure to carbon monoxide and volatile organic compounds in a mega city. *Urban Clim.* 21, 173–182.
- Odewale, S.A., Sonibare, J.A., Jimoda, L.A., 2017. Electricity sector's contribution to greenhouse gas concentration in Nigeria. *Manag. Environ. Qual. Int. J.* 28 (6), 917–929.
- Odogun, A., Georgakis, P., 2018. Transport pollution: a research of the Nigerian transport sector. *Int. J. Innov. Technol. Explor. Eng.* 8 (11), 492–497.
- Oduunlami, O.A., Elehinafe, F.B., Okorie, C.G., Abioye, O.P., Abioye, A., Fakinle, B.S., 2018. Assessment of in-tricycle exposure to carbon monoxide emission on roads in Nigerian urban centres. *Int. J. Mech. Eng. Technol.* 9 (9), 671–684. <http://www.iaeme.com/IJMET/index.asp>.
- Ogbuigwe, A., 2018. Refining in Nigeria: history, challenges and prospects. *Appl. Petrochem. Res.*
- Oghenejoboh, K.M., 2016. The impact of acid rain deposition resulting from natural gas flaring on the socio-economic life of the people of Afesere community, in Nigeria's Niger Delta. *J. Ind. Pollut.* 21 (1), 83–90.
- Ogunkunle, C.O., Fatoba, P.O., 2014. Contamination and spatial distribution of heavy metals in topsoil surrounding a mega cement factory. *Atmos. Pollut. Res.* 5 (2), 270–282.
- Ogunkunle, C.O., Abdulrahman, A.A., Fatoba, P.O., 2013. Influence of cement dust pollution on leaf epidermal features of *Pennisetum purpureum* and *Sida acuta*. *Environ. Exp. Biol.* 11, 73–79.
- Ogunsola, O.J., Oluwole, A.F., Asubiojo, O.I., Olaniyi, H.B., Akeredolu, F.A., Akanle, O.A., Spyrou, N.M., Ward, N.I., Ruck, W., 1994. Traffic pollution: preliminary elemental characterisation of roadside dust in Lagos, Nigeria. *Sci. Total Environ.* 146, 17–184.
- Oguntoke, O., Awanu, O.A., Annegarn, H.J., 2012. Impact of cement factory operations on air quality and human health in Ewekoro Local Government Area, South-Western Nigeria. *Int. J. Environ. Stud.* 69 (6), 934–945.
- Okedere, O.B., Sonibare, J.A., Ajala, O.E., Adesina, O.A., Elehinafe, F., 2017a. Estimation of sulphur dioxide emission from consumption of premium motor spirit and automotive gas oil in Nigeria. *Cogent Environ. Sci.* 3, 330456.
- Okedere, O.B., Fakinle, B.S., Sonibare, J.A., Elehinafe, F.B., Adesina, O.A., 2017b. Particulate matter pollution from open burning of sawdust in Southwestern Nigeria. *Cogent Environ. Sci.* 3, 1367112.
- Okedere, O.B., Fakinle, B.S., Sonibare, J.A., 2018. Annual estimates of air pollutants from utilization of diesel as energy source at base transceiver stations. *Environ. Qual. Manag.* 28, 129–135.
- Okedere, O.B., Olalekan, A.P., Fakinle, B.S., Elehinafe, F.B., Oduunlami, O.A., Sonibare, J.A., 2019. Urban air pollution from the open burning of municipal solid waste. *Wiley, Environ. Qual. Manag.* 28 (4), 67–74. <https://doi.org/10.1002/tqem.21633>.
- Oki, A.A., Fakinle, B.S., Sonibare, J.A., 2019. Criteria air pollutants from cement production in Nigeria. *Environ. Qual. Manag.* 28, 107–113.
- Okokon, Enembe O., et al., 2018. "Particulate air pollution and noise: assessing Commuter exposure in Africa's most populous city. *J. Transport Health* 9, 150–160. <https://www.sciencedirect.com/science/article/pii/S2214140517306369>. (Accessed 14 November 2018).
- Oladimeji, T., E Sonibare, J.A., Odufa, K.M., Ayeni, A., 2015a. Modeling of criteria air pollutant emissions from selected Nigeria petroleum refineries. *J. Power Energy Eng.* 3, 31–45.
- Oladimeji, T.E., Sonibare, J.A., Odufa, K.M., Oresegun, O.R., 2015b. Environmental impact analysis of emissions from petroleum refineries in Nigeria. *Energy Environ. Res.* 5 (1), 33–41.
- Oladipo, K., Felix, A.A., Bango, O., Chukwuemeka, O., Olawale, F., 2018. Power sector reform in Nigeria: challenges and solutions. In: *IOP Conf. Ser. Mater. Sci. Eng.*, Volume 413, The 2nd International Conference on Engineering for Sustainable World (ICESW 2018) 9–13 July 2018. Mechanical Engineering Department, Covenant University, Ota, Nigeria.

- Olatunji, O.S., Jimoda, L.A., Fakinle, B.S., Adeniran, J.A., Sonibare, J.A., 2015. Total sulfur levels in refined petroleum products of southwestern Nigeria Using UV/VIS spectrophotometer. *Petrol. Sci. Technol.* 33 (1), 102–109.
- Olowoporoku, A.O., Longhurst, J.W.S., Barnes, J.H., 2012. Framing air pollution as a major health risk in Lagos, Nigeria. *WIT Trans. Ecol. Environ.* 157, 472–486.
- Oseni, M.O., 2016. Get rid of it: to what extent might improved reliability reduce self-generation in Nigeria? *Energy Pol.* 93, 246–254. <https://www.sciencedirect.com/science/article/pii/S030142151630115X>. (Accessed 5 April 2019).
- Oyekale, A.S., Oyekale, T.O., 2017. Healthcare waste management practices and safety indicators in Nigeria. *BMC Publ. Health* 17, 740.
- Ozoh, O.B., Okor, T.J., Adetona, O., Akinkuge, A.O., Amadi, C.E., Esezobor, C., Adeyeye, O.O., Ojo, O., Nwude, V.N., Mortimer, K., 2018. Cooking fuels in Lagos, Nigeria: factors associated with household choice of kerosene or liquefied petroleum gas (LPG). *Int. J. Environ. Res. Publ. Health* 15 (4), 1–13.
- Pharm Access Foundation, 2015. Nigerian Health Sector Market Study Report. Study Commissioned by the Embassy of the Kingdom of the Netherlands in Nigeria. https://www.rvo.nl/sites/default/files/Market_Study_Health_Nigeria.pdf.
- Premium Times, 2014. Nigeria has 8 Million Registered Okada Riders – Association President. By Premium Times. April 11, 2014. <https://www.premiumtimesng.com/news/158562-nigeria-8-million-registered-okada-riders-association-president.html>.
- Price Water House (PWC), 2018. Assessing the Impact of Gas Flaring on the Nigeria Economy. <https://www.pwc.com/ng/en/assets/pdf/gas-flaring-impact1.pdf>.
- Ragothaman, A., Anderson, W.A., 2017. Air quality impacts of petroleum refining and petrochemical industries. *Environment* 4 (66).
- Ramanathan, V., Carmichael, G., 2008. Global and regional climate changes due to black carbon. *Nat. Geosci.* 1, 221–227.
- Runkel, M., Sturm, P., 2009. Pyrite roasting, an alternative to sulphur burning. *J. S. Afr. Inst. Min. Metall.* 109, 491–496.
- Rushdi, A.I., El-Mubarak, A.H., Mubarak, Lijotra.L., Al-Otaibi, M.T., Qurban, M.A., Al-Mutlaq, K.F., Simoneit, B.R.T., 2017. Characteristics of organic compounds in aerosol particulate matter from Dhahran city, Saudi Arabia. *Arab. J. Chem.* 10 (2), S3532–S3547.
- Sam, K., Zabbey, N., 2018. Contaminated land and wetland remediation in Nigeria: opportunities for sustainable livelihood creation. *Sci. Total Environ.* 639, 1560–1573.
- Sambo, A.S., Garba, B., Zarma, I.H., Gaji, M.M., 2014. Electricity Generation and the Present Challenges in the Nigerian Power Sector. Energy Commission of Nigeria. Abuja Nigeria. https://www.researchgate.net/publication/228399732_Electricity_Generation_and_the_Present_Challenges_in_the_Nigerian_Power_Sector.
- Schmutz, P., Tarjan, D., Günthard-Goerg, M.S., Matussek, R., Bucher, J.B., 1995. Nitrogen dioxide—a gaseous fertilizer of Poplar trees. *Phyton* 35, 219–232.
- Schraufnagel, D.E., 2020. The health effects of ultrafine particles. *Exp. Mol. Med.* 52, 311–317.
- Seleye-Fubara, D., Etebu, E.N., Athanasius, B., 2010. Pathology of deaths from carbon monoxide poisoning in Port Harcourt: an autopsy study of 75 cases. *J. Natl. Assoc. Resid. Doct. Niger.* 20, 337–340.
- Shareefdeen, Z.M., 2012. Medical waste management and control. *J. Environ. Protect.* 3, 1625–1628.
- Sheffield, P.E., Knowlton, K., Carr, J.L., Kinney, P.L., 2011. Modeling of regional climate change effects on ground-level ozone and childhood asthma. *Am. J. Prev. Med.* 41 (3), 251–257.
- Sheng, Q., Zhu, Z., 2019. Effects of nitrogen dioxide on biochemical responses in 41 garden plants. *Plants* 8 (45), 1–15.
- Singh, A., Agrawal, M., 2008. Acid rain and its ecological consequences. *J. Environ. Biol.* 29 (1), 15–24.
- Smith, K.R., Rogers, J., Cowlin, S.C., 2005. Household Fuels and Ill-Health in Developing Countries: what Improvements Can Be Brought by LP Gas (LPG)? World LP Gas Association & Intermediate Technology Development Group, Paris, France.
- Sonibare, J.A., 2010. Air pollution implications of Nigeria's present strategy on improved electricity generation. *Energy Pol.* 38, 5783–5789.
- Sonibare, J.A., Akeredolu, F.A., 2004. A theoretical prediction of non-methane gaseous emissions from natural gas combustion. *Energy Pol.* 32, 1653–1665.
- Sonibare, J.A., Akeredolu, F.A., Obanijesu, E.O.O., Adebisi, F.M., 2007. Contribution of volatile organic compounds to Nigeria's airshed by petroleum refineries. *Petrol. Sci. Technol.* 25, 503–516.
- Sridhar, M.K.C., Coker, A.O., Achi, C., 2018. Pollution from small and medium size enterprises: less understood and neglected sources in Nigerian environment. *J. Environ. Anal. Toxicol.* 8 (2), 558.
- Stewart, D.R., Saunders, E., Perea, R.A., Fitzgerald, R., Campbell, D.E., Stockwell, W.R., 2017. Linking air quality and human health effects models: an application to the Los Angeles air basin. *Environ. Health Insights* 11, 1–13.
- Strasert, B., The, S.C., Cohan, D.S., 2019. Air quality and health benefits from potential coal power plant closures in Texas. *J. Air Waste Manag. Assoc.* 69 (3), 333–350.
- Taylor, D., 2010. Biomass burning, humans and climate change in Southeast Asia. *Biodivers. Conserv.* 19, 1025–1042.
- Thompson, J.E., 2018. Airborne particulate matter human exposure and health effects. *J. Occup. Environ. Med.* 60 (5), 392–423.
- Tiwari, M.k, Bajpai, S., Dewangan, U.K., 2019. Environmental issues in thermal power plants—review in Chhattisgarh context. *J. Mater. Environ. Sci.* 10 (11), 1123–1134.
- Ubuoh, E.A., Nwajiobi, B., 2018. Implications of different household cooking energy on indoor air quality in urban and semi-urban Settlements in Imo, South Eastern Nigeria. *J. Appl. Sci. Environ. Manag.* 22 (5), 725–729.
- US EPA, 1995, fifth ed.. Compilation of air pollutant emission factors, vol. I: Stationary point and Area Sources. United States Environmental Protection Agency, Office of Air Quality Planning and Standards, Research Triangle Park NC, USA.
- US EPA, 1999. Nitrogen Oxides (NOx); Why and How They are Controlled. Technical Bulletin, United States Environmental Protection Agency. <https://www3.epa.gov/ttn/catc1/dir1/fnoxdoc.pdf>.
- US EPA, 2017. 2017 National Emissions Inventory. <https://www.epa.gov/air-emissions-inventories/2017-national-emissions-inventory-nei-documentation>.
- US EPA, 2018. Inventory of U.S. Greenhouse Gas Emissions and Sinks: 1990–2016 (430-P-17-001). <https://www.epa.gov/ghgemissions/inventory-us-greenhouse-gas-emissions-and-sinks-1990-2016>.
- US EPA, 2019. Nitrogen Dioxide Pollution (NO₂). <https://www.epa.gov/no2-pollution>.
- WHO, 2007. Health Relevance of Particulate Matter from Various sources. Report on a WHO Workshop, pp. 26–27. Bonn, Germany. https://www.euro.who.int/_data/asset/s/pdf_file/0007/78658/E90672.pdf.
- Winkel, A., Losada, J.M., Koerkamp, P.W.G.G., Ogink, N.W.M., Aarnink, A.J.A., 2015. Emissions of particulate matter from animal houses in The Netherlands. *Atmos. Environ.* 111, 202–215.
- Won, W.S., Oh, R., Lee, W., Kim, K.Y., Ku, S., Su, P.C., Yoon, Y.J., 2020. Impact of fine particulate matter on visibility at Incheon International Airport, South Korea. *Aerosol Air Qual. Res.* 20, 1048–1061.
- World Bank, 2014. Diesel power generation: inventories and black carbon emissions in Nigeria. <http://documents1.worldbank.org/curated/en/853381501178909924/pdf/117772-WP-PUBLIC-52p-Report-DG-Set-Study-Nigeria.pdf>. (Accessed 15 January 2021).
- World Bank, 2015. Second Pollution Abatement Project in Egypt, Arab Republic of: Implementation Completion and Result Report.
- World Bank, 2019. The Dirty Footprint of Broken Grid: the Impacts of Fossil Back-Up Generators in Developing Countries. <https://www.ifc.org/wps/wcm/connect/2cd3d83d-4f00-4d42-9bdc-4afdc2f5dbc7/20190919-Full-Report-The-Dirty-Footprint-of-the-Broken-Grid.pdf?MOD=AJPERES&CVID=mr9UpXC>. (Accessed 15 January 2021).
- Wyzga, R.E., Rohr, A.C., 2015. Long-term particulate matter exposure: attributing health effects to individual PM components. *J. Air Waste Manag. Assoc.* 65 (5), 523–543.
- Zajemska, M., Musiał, D., Radomiak, H., Poskart, A., Wyleciał, T., Urbaniak, D., 2014. Formation of pollutants in the process of co-combustion of different biomass grades. *Pol. J. Environ. Stud.* 23 (4), 1445–1448.
- Zakaria, M.P., Geik, K.H., Lee, W.Y., Hayet, R., 2005. Landfill leachate as a source of polycyclic aromatic hydrocarbons to Malaysian Waters. *Coastal Marine Science* 229 (2), 116–123.
- Zevin, S., Saunders, S., Gourlay, S.G., Jacob, P., Benowitz, N.L., 2001. Cardiovascular effects of carbon monoxide and cigarette smoking, 38 (6), 1633–1638.
- Zhang, J.J., Wei, Y., Fang, Z., 2019. Ozone pollution: a major health hazard worldwide. *Front. Immunol.* 10, 2518.
- Zhou, J., Wang, T., Zhang, Y., Zhong, N., Medeiros, P.M., Simoneit, B.R.T., 2009. Composition and sources of organic matter in atmospheric PM₁₀ over a two year period in Beijing, China. *Atmos. Res.* 93, 849–861.