

# Automatic Electrical Appliances Control Panel Based on Infrared and Wi-Fi: A Framework for Electrical Energy Conservation

Emmanuel ADETIBA, Victor O. MATTHEWS, Ayokunle A. AWELEWA, Isaac A. SAMUEL, Joke A. BADEJO

**Abstract-**Today, proprietary home automation targets very specific applications which operate mostly on a cable based infrastructure. In contrast to that, our implementation builds on a wireless platform for the automatic control of house hold electrical appliances. The nodes gather sensor readings in a home and transmit them to a central automation server. There, the readings are matched against a list of script statements. When there is a match, a specific action is performed. An important property of the system is that the control of all home appliances is done by means of the ubiquitous Infrared and Wi-Fi wireless technologies. This way, the co-operation between manufacturers is not a necessity in order to connect devices to the home automation network.

**Keywords-** Automation, infrared, Wi-Fi, automatic control.

## 1 INTRODUCTION

Home automation offers a not yet exploited degree of convenience, both for the private home and the office. Although the idea has been around for many years, the market can still be considered to be in its infancy. Today's home automation solutions are mostly proprietary. They usually target a small number of problems, such as satisfying security needs or the control of a limited number of devices, typically all from the same manufacturer. They operate based on a particular infrastructure, which requires extra cabling. So they are best suited for new buildings. They are limited to the applications a manufacturer offers.

However, the future proliferation of home automation systems will depend on its ease of installation. This is why we argue for this research work the use of wireless in the implementation of home automation. Specifically, the use of Wi-Fi is an effective solution for post installations of historic buildings which can not be remodeled.

At the same time, we believe that an even more important aspect to making the smart home a success will be to offer more freedom for a user to customize home automation application to his specific needs.

In short, the idea of this research work is to gather all kinds of sensor readings possible in a home and forward them hop-by-hop to an embedded system to which we refer as the home automation controller. Each time a new or configured event is detected, the controller runs over a list of already configured script statements which is triggered by the user. When there is a match between the received event and the matching part of a statement, one or more actions are performed which are detected by the sensor nodes, accessed & processed by the microcontroller and then implemented by a switching panel via the use of wireless (Wi-Fi) technology.

The strength and contribution of this work lies in the combination of a large number of sensors (e.g. infrared counter & a light dependent resistor) readings which allows deriving higher level semantics as compared to reacting on single sensor readings only[1,2,4].

Our system operates on an in-built electronic processing and data storage system that has the ability to make intelligent decisions on the control and regulation of appliances in a given room or specified area. It is a self regulating system programmed to adjust to changes in the environment by the use of sensors (infrared detectors(IR) and light dependent resistors(LDR)) which are triggered by

the entry of people into a given area at a given time of the day (i.e. day or night).

The system makes decisions based on the number of persons occupying a given room (displayed on a seven segment display) and the timing of the day by automatically switching and regulating the fixtures and appliances which for the purpose of this project are switching of lighting systems, switching and regulation of a ventilation system (fan) and control of a curtain system based on the programming decisions of the microcontrollers.

The infrared detectors are situated at the entrance of the room where the equipment is to be installed as to make decisions on whether it is day or night. The timing (day or night) plays a vital role in the decision making process of the microcontroller as to determine which appliance is to be powered.

Emphasis is laid between the connectivity of the decision making microcontroller and the relay used for the switching of the appliances. For these purpose, Wi-Fi is incorporated for sending of control signals between the microcontroller and the relay.

All these self regulatory system controls are done without human intervention making it an ideal system for optimal use of power and automatic control of appliances in this era of automated control of systems.

## 2 LITERATURE REVIEW

Since the beginning of electrification, switching electrical devices has been done by means of connecting or disconnecting them to the power grid. In recent years, physically disconnecting a device from its energy source has become less popular. Instead, switching is done electronically (automatically). This means that the inner device is separated from the switching circuit. As a consequence, the device can be powered on or off by a remote control or in the case of this research work by an automated switching panel based on the number of persons occupying a room. Some computer main boards even allow reaction to power network events. However, the downside is that the switching unit keeps consuming energy as long as it stays on.

Specific domestic wiring and communication standards include BACnet, INSTEON, X10, PLC

while the LDR is situated in a convenient arbitrary location so as to be able to detect sunlight. The infrared sensor is used to determine the number of persons occupying a room via the cutting of the infrared rays. These rays generate an interrupt signal response output. This output is sensed by a microcontroller which then makes decisions as to what load or fixture should be powered by switching a relay that uses AC to power the loads.

The second sensor which is the LDR is used to detect the presence of sun-light so

BUS, KNX (standard), System Box, LonWorks, C-Bus, SCS BUS with OpenWebNet, Universal Powerline Bus (UPB), UPnP, ZigBee and Z-Wave that will allow for control of most applications. Some standards use communication and control wiring, some embed signals in the power line, some use radio frequency (RF) signals, and some use a combination of several methods. Control wiring is hardest to retrofit into an existing house. Some appliances include USB that is used to control it and connect it to a domotics network. Bridges translate information from one standard to another (e.g. from X10 to European Installation Bus) [2,3].

The changing paradigm in home automation is also that a device is no longer disconnected from the power grid. The function of the switch on the wall or even in the device is taken over by a network which is solely for signaling events. The network which controls devices by transmitting datagrams is powered with a much lower current. The earliest instance of a pure datagram based network standard for building automation is the European Installation Bus (EIB) standard implemented in 1992[1,5,6].

Earlier home automation systems like the X10 system combined the signaling network with the power grid. This technology which is *power-line* based has regained popularity recently as an alternative to Digital Subscriber Line (DSL) technology which requires dedicated signaling cables like telephone lines. However, power-line based systems have inherent problems like radio interference, security flaws and reliability issues which have never been solved completely [1,3]. INSTEON technology is a dual-band mesh topology employing AC-power lines and a radio-frequency (RF) protocol to

communicate with and automate home electronic devices and appliances, which normally work independently. It is a home automation networking technology invented by SmartLabs, Inc. INSTEON was developed, based on the X10 model, for control and sensing applications in the home [6,8,9]. INSTEON is designed to enable simple devices to be networked together using the power-line and/or radio frequency (RF). All INSTEON devices are peers, meaning each device can transmit, receive, and repeat any message of the INSTEON protocol, without requiring a master controller or complex routing software. According to a *Popular Mechanics* magazine article, INSTEON is not only "an effective system for connecting lighting switches and loads without extra wiring, but it also forms the basis for a more sophisticated home automation network." [7,8]. However, sensing of occupants and detection of day/night are not incorporated in INSTEON.

### 3 MATERIALS AND METHODS

The circuitry of the system is divided mainly into two parts which are the sensory system (charging system, infrared sensors, microcontroller 1, seven segment display, digital signal transmitter, etc.) and the switching system (charging system, digital signal receiver, microcontroller 2, transistors, relays, appliances, etc.). The wireless connectivity which makes use of Wi-Fi enables control signals to be transferred between the sensory and switching system. The Wi-Fi connectivity uses Amplitude Shift Keying (ASK) as its modulation scheme. The block diagram of the entire system is shown in figure 1.

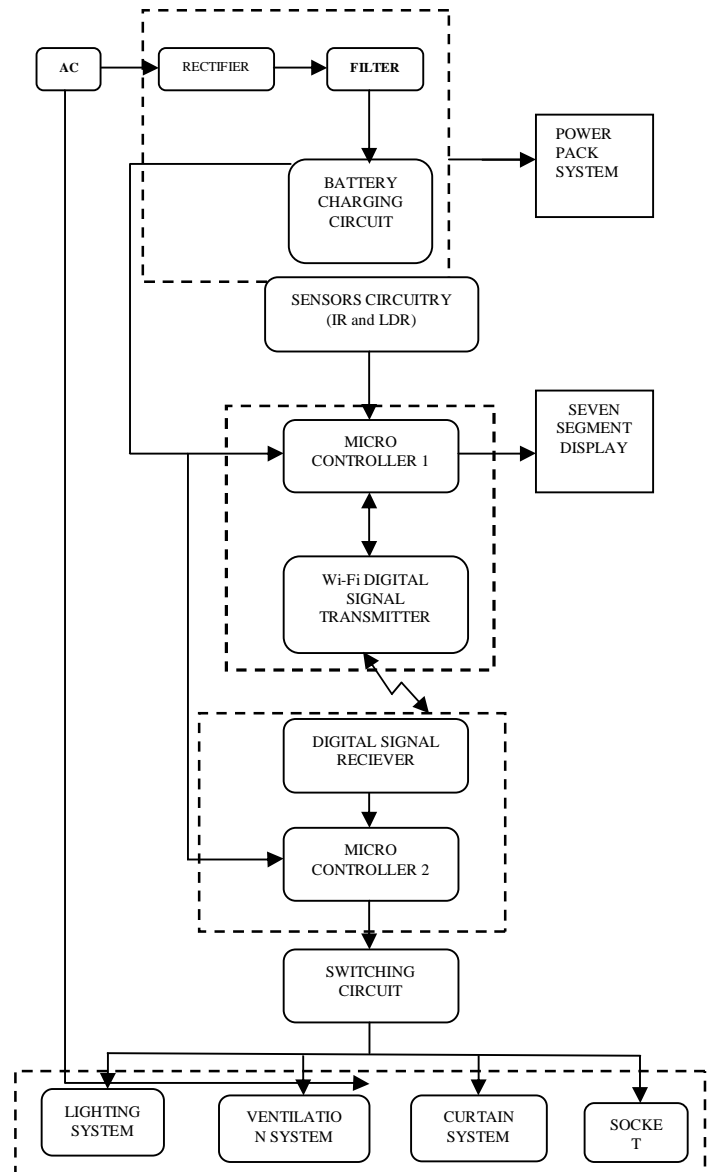

Fig. 1. Block diagram of the Automatic Electrical Appliances Control Panel Based on Infrared and Wi-Fi

The hardware implementation basically consists of its circuitry and interrelation of components. The

hardware module is divided into the transmitting circuit and the receiving circuit.

## 4 RESULTS AND DISCUSIONS

The operation of the circuit is dependent on the time of the day (daylight or night) and on the interruption of the infrared rays by occupants of the room.

### 4.1 Daylight Testing Operation

During the day, as soon as the infrared ray is interrupted, the circuit comes on and the microcontroller in the transmitting circuit acts on the information it collects from the sensors (the LDR and the infrared) and sends the control instruction to the microcontroller in the receiving circuit which effects the appropriate action. The fan has two set limits for its speed which are; speed 1 (when the number of people in the room does not exceed four), speed 2 (when the number of people in the room exceeds four)

The microcontroller is able to know the number of people in the room per time through accurate monitoring of the infrared interruptions by incrementing or decrementing (counting effect) which is constantly displayed on the seven segment display. The test scenario which is based on a multi-phase sequence with an increment of five is outlined in the figure 2 to figure 7.



Fig. 2. Pictorial representation of the people counter in operation

a.) When the display reads 1

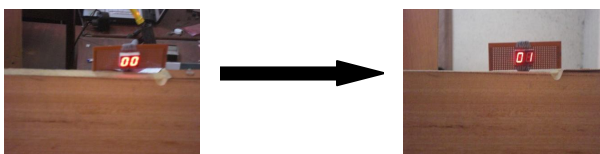

Fig. 3. Pictorial view of seven segment displaying transgression from 0-1 when there is an occupant in the room.

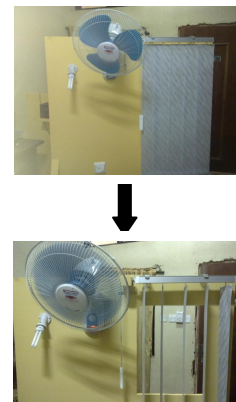

Fig. 4. Pictorial view of operational transition of appliances in day mode when there is an occupant in the room (the fan is on, the bulb is off and the curtain is opened).

b.) When the display reads (5)

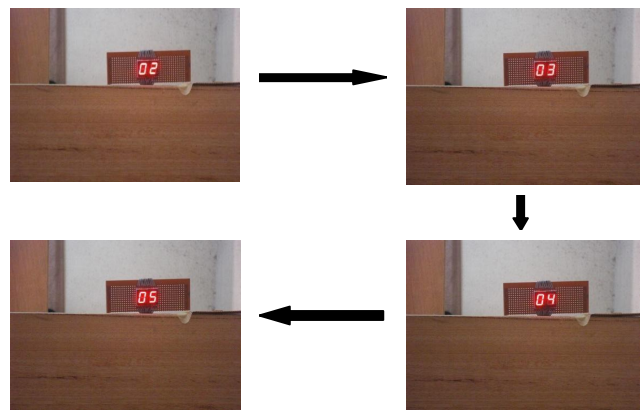

Fig. 5. Pictorial view when there are five occupants in the room

c.) When the display reads (0)



Fig. 6. Pictorial view of people counter displaying 0



Fig. 7. Pictorial view of appliances when deactivated

#### 4.2 Night Testing Operation

The night operation is the same with the daylight operation mode with a few exceptions. Once there is a change in the LDR to signal night mode, the following occurs in the test scenario for the different phases:

a.) When the display reads one (1)

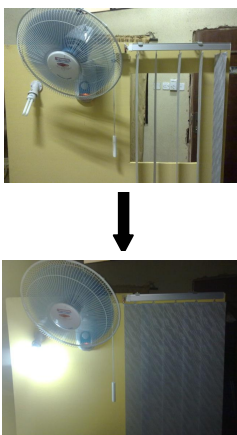

Fig. 8. Appliances in night mode operation

b.) When the display reads (5)

The operation is the same as phase A with an exception to the speed of the fan which increases to speed 2.

c.) When the display reads (0): The electricity supplied to the appliances in the room is cut off and the lighting system goes off in order to conserve power. The curtains remain closed. The ventilation system (fan) is deactivated. The socket is deactivated. The simulation software used for the testing of this project is proteus. The signal output from the oscilloscope signifies that the microcontroller has sent a trigger signal which is transferred to the digital signal transmitter.

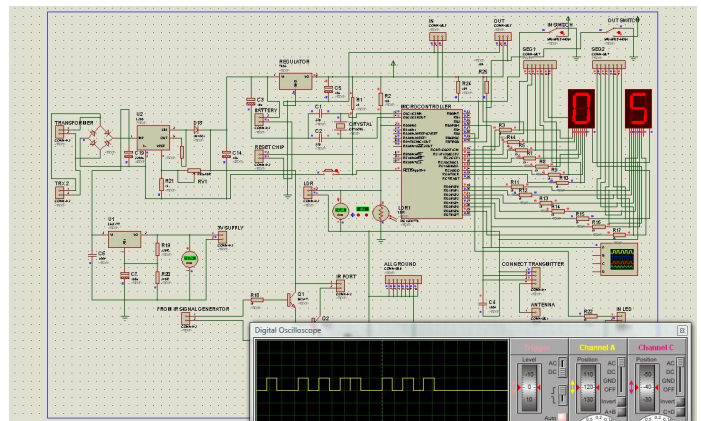

Fig. 9. System simulation and testing

## 5 CONCLUSION

The prototype of our *Automatic Electrical Appliances Control Panel Based on Infrared and Wi-Fi* is fully ready and functional. Real time implementation and deployment of the system has a huge potential of minimizing energy wastage in both domestic and industrial electrical installations. This promises to be a relevant energy conservation model both for the developing and developed countries.

However, for future prototypes and improvements; a microcontroller and Wi-Fi module bundled by manufacturers to achieve faster communication between the transmitter and receiver will be utilized. Also, a triac based circuit can be used in the

switching module implementation in place of the relays. This will help to achieve faster switching speeds and less power consumption. Appliances can be constructed to have intelligent control features, for instance, the fan may not come on when the temperature is low in the night or the weather is cool during the day.

## REFERENCES

- [1] Adebisi, G. (2010). Nigeria's Epileptic Electricity, Don Advances Permanent Solution. <http://www.osundefender.org/?p=5365/>. Accessed 26 August 2010.
- [3] Delgado, A. R., Picking, R., and Grout V. (2006) Remote-controlled home automation systems with different network technologies, *Proceedings of the 6th International Network Conference, University of Plymouth*, 357-366.
- [4] Ciubotaru-Petrescu, B.G., Chiciudean, D., Cioarga R., and Stanescu D. (2006). Wireless Solutions for Telemetry in Civil Equipment and Infrastructure Monitoring, *3rd Romanian-Hungarian Joint Symposium*.
- [5] Conte G., Scaradozzi D. (2003). Viewing home automation systems as multiple agents systems. [http://www.robosiri.it/ROBOCUP\\_2003/ROBOCUP-SITOSIRI/articles/pdf/Conte.pdf](http://www.robosiri.it/ROBOCUP_2003/ROBOCUP-SITOSIRI/articles/pdf/Conte.pdf). Accessed 20 August 2010.
- [7] Malik Sikandar, H. K., Aihab K., Erum S. (2009). SMS Based Wireless Home Appliance Control System (HACS) for Automating Appliances and Security. *Issues in Informing Science and Information Technology*, 6, 887--894.
- [8] Goldsmith A. (2005). *Wireless Communications*. Cambridge University Press.
- [9] Molisch A. (2005). *Wireless Communications*. Wiley-IEEE Press.

*Emmanuel ADETIBA is a lecturer and he is currently pursuing his Ph.D degree at Covenant University, College of Science and Technology, Department of Electrical & Information Engineering, Ota, Nigeria, E-mail: emmanueladetiba@gmail.com*

*Victor O. MATTHEWS is a Ph.D holder and he is currently a senior lecturer at Covenant University, College of Science and Technology, Department of Electrical & Information Engineering, Ota, Nigeria, E-mail: vomatthews2@yahoo.com*

*Ayokunle A. AWELEWA is a lecturer and he is currently pursuing his Ph.D degree at Covenant University,*

*College of Science and Technology, Department of Electrical & Information Engineering, Ota, Nigeria, E-mail: anody\_awe@yahoo.com*

*Isaac A. SAMUEL is a lecturer and he is currently pursuing his Ph.D degree at Covenant University, College of Science and Technology, Department of Electrical & Information Engineering, Ota, Nigeria, E-mail: isaacsamuel2003@yahoo.com*

*Joke A. BADEJO is a lecturer and she is currently pursuing her Ph.D degree at Covenant University, College of Science and Technology, Department of Electrical & Information Engineering, Ota, Nigeria, E-mail:joke.badejo@covenantuniversity.*

