

PAPER • OPEN ACCESS

Overview for Improving Steam Turbine Power Generation Efficiency

To cite this article: Abolaji Joseph Omosanya *et al* 2019 *J. Phys.: Conf. Ser.* **1378** 032040

View the [article online](#) for updates and enhancements.

You may also like

- [Research of Turbine Oil Varnish in Generator Unit](#)
Haoya'nan, Li Qiang, Yu Naihai et al.
- [A fast response miniature probe for wet steam flow field measurements](#)
Ilias Bosdas, Michel Mansour, Anestis I Kalfas et al.
- [Increasing the manoeuvrability of power units of the thermal power plants due to applying the hydrogen-oxygen systems](#)
Victor Solovey, Mykola Zipunnikov and Roman Rusanov



The Electrochemical Society
Advancing solid state & electrochemical science & technology

243rd Meeting with SOFC-XVIII

Boston, MA • May 28 – June 2, 2023

Accelerate scientific discovery!

Learn More & Register



Overview for Improving Steam Turbine Power Generation Efficiency

Abolaji Joseph Omosanya^{1*}, Esther Titilayo Akinlabi^{1,2} and Joshua Olusegun Okeniyi^{1,2}

¹Department of Mechanical Engineering Science, University of Johannesburg, Johannesburg, South Africa.

²Department of Mechanical Engineering, Covenant University, Ota, Ogun State, Nigeria
Corresponding Author; deenkelson@gmail.com

Abstract-

Electricity is an integral part of every society for which demand is growing continuously, whereas the production is still based on limited sources of energy derived mainly from steam and gas turbines, the turbomachinery. This paper presents an overview for preliminary study on the optimization of the design of the steam turbine. This was done with a special focus on the last stage low pressure turbine blades, for the reason that the design parameters of this component exhibit influence on the efficiency of power generation from the steam turbine electric power generating system. For supporting the study, a practical overview of the Egbin thermal power station, Nigeria, was included in the study with the parameters from the last stage low pressure turbine blade for this energy generation installation. By these, suggestions that could be undertaken for improving efficiency of the steam power plant for enhancing sustainability of electric power generation were also detailed in the paper.

Key words: Turbine blade, Efficiency, CFD

1. Introduction

Man needs and uses energy at an increasing rate for his sustenance and wellbeing ever since he came on earth some million years ago [1-2]. The continued rise in World's population with the seemingly increase in demand for power has indisputably highlighted the need to increase power generation capacities. According to global statistics [3], energy supply has shown a steady increase in the past years. In spite of these, however, it is still generally considered that the available energy generation plants are not sufficient to produce the required power [4-5], thereby necessitating needs to invest more in the construction of new power generation plants or seek alternative forms of energy generation. For remaining competitive, therefore, it is important for power generation companies and private power operators to seek ways for optimizing existing plants in order to improve efficiency and reliability, as well as to reduce the cost of plant operations and maintenance [6-7]. Although, there is renewed interest for sustainable, renewable and affordable energy technologies, the main energy producers still employ turbomachines, with the dominant primary source of energy being the fossil fuels, the versatile primary energy generation source globally [8-9]. However, environmental restrictions ensuing from emissions from fossil fuel combustions are driving researchers and stakeholders towards the search for more efficient electric energy generation systems [10-12]. Turbomachinery driven thermal power plants for generating electricity via fossil fuel can employ any of internal combustion plants, nuclear power plants, gas turbine plants, or steam power plants which amounts to about 80% of the electricity generated worldwide [11]. In this paper, the overview of steam power generating plant was deliberated upon with a view towards



improvement of electric energy generation efficiency that could lead to cost saving and reduced environmental impacts.

2. Steam Power System for Electricity Generation

2.1 The turbomachinery and turbine energy generation system

The prominent forms of energy used in the industrial process for heating are electricity, direct-fire heating and steam. Heating using electricity basically involve the use of heating elements (normally resistors) which converts the electrical current flowing through it to heat energy. For direct-fire heating, hot gases from a burner transfer their heat energy to the system. Steam which is the predominantly used form of energy for process heating is also used for pressure control, mechanical drive, and is sometimes directly injected into the process as a source of water for process reactions. Steam is often used compared to other sources of energy for heating because of its performance advantages that include non-toxicity, ease of distribution, high heat capacity and low running and set-up cost.

The turbomachinery generally transfers energy between a fluid and a rotor. While a turbine transfers energy from a fluid to a rotor, a compressor transfers energy from a rotor to a fluid. The overall efficiency of the simple steam power plant is generally lower than that of other power plants such as the hydro, diesel and nuclear power plants. Therefore, the design engineer aims at producing a steam turbine characterized by an optimal energy conversion with an optimum efficiency. The overall efficiency of a steam turbine power plant solely depends on the performance and reliability of the turbine and its components. Thus any slight improvement can increase power availability, improve reliability, decrease equipment and component costs, and generate tangible operational savings. Taking into consideration the pronounced use of turbines in power generation, minor improvement in efficiency have both economic and environmental advantages for it will transform into billions of savings and result in reduced emission per unit of energy generation [6,13].

2.2 Efficiency improvements in steam turbine power plants

In the last three decades, engineers and designers have done several researches, simulations and experimentations on turbine systems to make industrial steam turbines more efficient and reliable [14]. These works have led to the improvement and the design of more powerful, efficient, and reliable steam turbines and the development of new materials and manufacturing processes. During the past years, the steam turbine inlet temperatures have been increased further for improving the efficiency of the steam plant, especially, with recent designs having up to 620 °C inlet temperature even as this can still be increased in the near future [15]. This increment makes the review into the heat transfer characteristics of the materials chosen for the design of the turbine and most especially the turbine blades to be important and necessary. In addition, the structural integrity of all rotating components, mainly the rotor and the shaft is a key factor for successful, efficient and reliable operation of any turbomachinery. The integrity depends on the successful resistance of the moving parts of the turbine to the steady and alternating stresses imposed on them, both internally by the heat transferred and externally by the pressure from the steam. Due to the high cost of setting up a steam power generation plant, it is important to have an optimal design to maintain good returns on the capital investments by the power generation companies. Thus, the turbine has to be designed in such a way that

overdesigning of the parts - such as blade and material selection - is avoided while fulfilling their basic requirement.

2.2.1 The energy cycle for the steam power turbine system

Figure 1 below shows the ideal Rankine cycle. Steam power plants are assumed to follow this ideal thermodynamic cycle for the explanation of their basic processes. It involves two isentropic and two isobaric processes. However, for practical operation, the working fluid is reheated and made to run through another turbine before going to the condenser. The thermodynamic processes through the states of the cycle shown in Figure 1 are:

- 1-2: Isentropic compression. Saturated liquid enters the pump at state 1 is pumped from low pressure to the pressure required by the boiler.
- 2-3: Isobaric heat addition. The saturated water in the boiler at the required pressure is heated up by an external heat source and leaves as superheated vapour.
- 3-4: Isentropic expansion. The superheated vapour expands in the turbine which is used to drive a generator to produce power.
- 4-1: Isobaric heat rejection. The vapour is condensed to saturated liquid in the condenser.

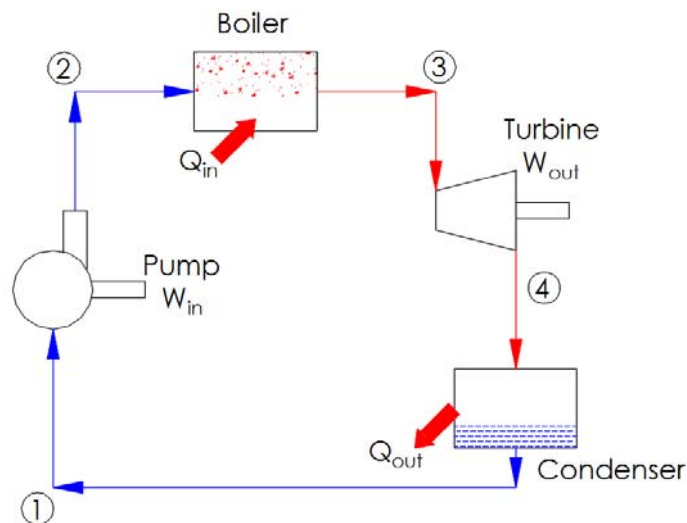

Figure 1: The ideal Rankine cycle for a steam power generation plant

The turbine is the equipment responsible for the isentropic expansion which refers to the state 3 to 4 of the four reversible processes of the steam generation plant, as shown from the ideal Rankine cycle of a steam power generation plant in Figure 1. For the steam generating plant design, the turbines are composed of several pairs of stationary (stator) and rotating (rotor) blade rows. The superheated steam with high velocity and pressure passes through the stationary blade rows also called nozzles and hits the rotating blades, sometimes referred to as buckets which are mounted on a shaft. The design of the nozzles and diaphragms of a turbine helps to drive the flow of the steam into a well formed, high velocity jets as the steam expands from inlet pressure through the various sections of the turbine blade to the exhaust pressure. This steam after passing through the nozzle produces a dynamic pressure on the blades installed on the rotor in which the blades and the shaft both start to rotate in the same direction [16]. The next

arrangement of stationary blades helps to increase the velocity of the steam in a circumferential direction towards the next set of rotary blades. In a steam turbine, the mechanical energy in form of pressure present in steam is extracted and converted into kinetic energy by allowing the steam to flow through the stationary blades. This kinetic energy is transmitted to the moving blades connected to the alternator of a steam turbine generator. Turbine generator converts the mechanical energy from the rotor in form of rotary motion into electrical energy.

The turbine blade is the most important element in the steam power generation system as it transmits the pressure energy from the steam to the rotor. Turbine blades can be classified based on their interaction with the steam as impulse or reaction blades. It is important to note that turbine blades are not exactly the same throughout the section of the steam turbine. Steam turbines are designed with multi steam expansion stages, which are basically high, intermediate and low pressure stages [9]. In this paper, emphasis will be made on the low pressure (LP) turbine blade, which is in the last stage of the turbine and that is, characteristically, the longest blade system of the turbine.

2.2.2 Factors affecting efficient steam power turbine blade design

The LP, which is also the last stage, turbine blade is characterized by a number of issues due to the length of its blades. These issues, among others, include large centrifugal stress, low rigidity and high Mach number flow. The overall thermal efficiency of the steam turbine as well as its size and total power output significantly depend on the last stage blades, the reason for which designing an optimal range of last stage blades is important [17]. The life span of the turbine blades is influenced by a number of parameters. Unlike blades of a compressor, turbine blades experiences harsh forces acting within its environment ranging from high operating temperatures to high varying blade load. Other factors affecting the life span of the turbine blade include flow mismatch during water and steam ejection at the extraction ports, partial or imperfect vacuum, water injection, incorrect steam conditions, presence of impurities in the steam, etc. During the design of the turbine blade, it is required of the design engineer to [18]:

- Make a choice of the mechanical and steam loading of the steam turbine taking each individual blade into consideration;
- Select the shroud and root configuration for each stages of the turbine;
- Determine the stiffness required for the rotor root;
- Make material choice based on hardness, machinability, surface finishing; as well as
- Determine the tightness of the installation.

It is these listed considerations that necessitate the importance of having to strike a balance between the conflicting requirements of low cost, good aerodynamic performance, and long life, when designing a blade for the steam power generating turbine system. Therefore, the optimization of these design choices will therefore go a long way towards improving steam power generation efficiency by the turbine system in an electric power generation plant.

3. A Practical Overview: The Egbin Power Plant, Nigeria

For a practical overview, this paper examines the steam power turbine system for electric energy generation at the Egbin thermal power plant, Nigeria. The plant is located at Ikorodu, Lagos State, Nigeria [13]. The plant, which has six turbine stations, was commissioned in 1987. Each individual station operates on a reheat-regenerative cycle and can be fired using either gas or heavy oil. The construction of the plant commenced in 1984 under the supervision of the

Japanese and French contractors with most of the equipment, including the Hitachi turbine being used at the plant, were sourced from Japan. The budget estimate of the plant was about 1 billion USD at that time while the life span of the plant was estimated at 25 years. According to [19], efficiency of the plant was averaged at 34.67% under the review period of 2000 to 2010. However, in 2016, the plant recorded an overall efficiency of 29% based on the output/input method of calculation [20]. This shows a significant drop in the efficiency of the power station, and thus, necessitates the needs for reviewing the system for improvement possibilities. In this study, the analysis for improvement being proposed is being carried out on the turbine blade. To improve the efficiency of the blade rows, the flow pattern of individual stage will need to be redesigned considering all the fluid forces acting on the end-wall contour of the steam turbine and the blade profile [21].

The Egbin power station, like any other steam power plant, works on the principles of the Rankine reheat regenerative cycle. The most efficient cycle for thermodynamic operation is the Carnot cycle but it is not practicable for steam power cycle because it is difficult to design a compressor which could handle working fluid that is in both liquid and vapour state. It is also difficult to control the condensation process to produce the working fluid in the desired state for compression.

Figure 2 shows the image of the last stage low pressure turbine blade currently in use at Egbin thermal power plant. The operational parameters of this turbine blade are as presented in Table 1.



Figure 2: Last stage low pressure turbine blade

Table 1: Operational parameters of the last stage low pressure turbine blade from Egbin power plant

Parameter	Unit	Value
Rotational speed	rpm	3000
Blade length	mm	750
Chord length	mm	45
Reynolds number	dimensionless	4.9×10^5
Velocity	m/s	34.14
Coefficient of viscosity	kg/ms	1.009×10^{-5}

Considering that the operational parameters of the last stage low pressure turbine blade system, shown in Figure 2, will exhibit dependencies on the blade length, aerofoil design and steam exhaust characteristics, it could therefore be inferred the efficiency of the steam turbine electric power generation plant could be improved by:

- Increasing the length of the low pressure last stage turbine blades that will lead to reduced exhaust loss, and which, in turn, will bring about increase in the capacity of the turbine, thus, improvement to the efficiency of the steam turbine plant. This, when viewed broadly reduces the cost of construction against power/capacity of the turbine.
- Optimizing the aerofoil design and improving the angle of attack. The profile of the aerofoil determines how effectively the kinetic energy of the steam will be converted to mechanical energy. An optimized design of the aerofoil will ensure a better percentage of the kinetic energy of the steam is used in the turbine.
- Enlarging the steam exhaust at the low pressure turbine. Steam expands more in the low pressure turbine, hence, the long turbine blades. If the exhaust of the low pressure turbine is not wide enough to accommodate the rate of expansion, back pressure will be experienced by the blades which will inhibit the overall efficiency of the power plant.
- Conducting further research into the materials properties of the low pressure turbine blade for steam turbine power generating system, especially, towards the improvement of efficiency that could be induced from improved turbine materials properties.

4. Conclusion

An overview for improving steam power turbine energy generation efficiency has been carried out in this work. The conclusion following from the study includes:

- Sustainability for the purpose of lower cost, leading to economical generation of electric power, and environmental effects via reduced emission per unit of energy generation, by using the steam power generation plant will require improving the system efficiency.
- It could be possible to improve efficiency of the steam turbine power plant system through optimization of the design parameters of the last stage LP turbine blade.
- It will also be necessary to conduct further research into the materials properties of the LP turbine blade for steam power generation system for the improvement of efficiency improvement that could be accrued from improve turbine materials properties.

Acknowledgements

The authors wish to acknowledge the support offered by Egbin thermal power station in actualization of this research work for publication.

Reference

- [1] Okeniyi, J. O., Moses, I. F. and Okeniyi, E. T. (2015). Wind characteristics and energy potential assessment in Akure, South West Nigeria: Econometrics and policy implications. *International Journal of Ambient Energy*, 36(6), 282–300.
- [2] Ajayi, O. O., Fagbenle, R. O., Katende, J. and Okeniyi, J. O. (2011). Availability of wind energy resource potential for power generation at Jos, Nigeria. *Frontiers in Energy*, 5(4), 376–385.
- [3] The International Energy Agency (IEA) (2018). Total Primary Energy Supply (TPES) by source: World 1990 – 2016. *IEA Key energy statistics* <https://www.iea.org/statistics/?country=WORLD&year=2016&category=Energy%20supply&indicator=TPESbySource&mode=chart&dataTable=BALANCES> Accessed: July 11, 2019.
- [4] Okeniyi, J. O., Atayero, A. A., Popoola, S. I., Okeniyi, E. T. and Alalade, G. M. (2018). Smart campus: data on energy generation costs from distributed generation systems of electrical energy in a Nigerian University. *Data in Brief*, 17, 1082–1090.
- [5] Okeniyi, J. O., Anwan, E. U. and Okeniyi, E. T. (2012). Waste characterisation and recoverable energy potential using waste generated in a model community in Nigeria. *Journal of Environmental Science and Technology*, 5(4), 232–240.
- [6] Ray, T. K., Datta, A., Gupta, A. and Ganguly, R., 2010. Exergy-based performance analysis for proper O&M decisions in a steam power plant. *Energy Conversion and Management*, 51(6), 1333–1344.
- [7] Mahamud, R., Khan, M. M. K., Rasul, M. G. and Leinster, M. G. (2013). Exergy analysis and efficiency improvement of a coal fired thermal power plant in Queensland. In M. Rasul, *Thermal Power Plants – Advanced Applications*. IntechOpen. DOI:10.5772/55574
- [8] Ajayi, O. O., Fagbenle, R. O., Katende, J., Aasa, S. A. and Okeniyi, J. O. (2013). Wind profile characteristics and turbine performance analysis in Kano, north-western Nigeria. *International Journal of Energy and Environmental Engineering*, 4(1), 27.
- [9] Rosen, M. A. and Tang, R. (2008). Improving steam power plant efficiency through exergy analysis: effects of altering excess combustion air and stack-gas temperature. *International Journal of Exergy*, 5(1), 31–51.
- [10] Okeniyi, J.O., Loto, C.A. and Popoola, A.P.I. (2014). *Morinda lucida* effects on steel-reinforced concrete in 3.5% NaCl: Implications for corrosion-protection of wind-energy structures in saline/marine environments. *Energy Procedia*, 50, 421-428.
- [11] Jonshagen, K. (2011). *Modern Thermal Power Plants-Aspects on Modelling and Evaluation*. Doctoral dissertation, Department of Energy Sciences, Lund University, Sweden.
- [12] Ajayi, O. O., Fagbenle, R. O., Katende, J., Okeniyi, J. O. and Omotosho, O. A. (2010). Wind energy potential for power generation of a local site in Gusau, Nigeria. *International Journal of Energy for a Clean Environment*, 11(1-4), 99–116.
- [13] Eke, M. N., Onyejekwe, D. C., Iloeje, O. C., Ezekwe, C. I. and Akpan, P. U. (2018). Energy and exergy evaluation of a 220MW thermal power plant. *Nigerian Journal of Technology*, 37(1), 115–123.
- [14] Singh, M. P. and Lucas, G. M. (2011). *Blade Design and Analysis for Steam Turbines*. The McGraw-Hill Companies, New York.
- [15] Fadl, M., Stein P. and He, L. (2017). Full conjugate heat transfer modelling for steam turbines in transient operations. *International Journal of Thermal Sciences*, 124, 240–250.

- [16] Bloch H. P. and Singh M. P. (2009) *Steam Turbines; Design, Applications, and Rerating*. The McGraw-Hill Companies, New York.
- [17] Senoo, S., Ono, H., Shibata, T., Nakano, S., Yamashita, Y., Asai, K., Sakakibara, K., Yoda, H. and Kudo, T. (2014). Development of titanium 3600rpm-50inch and 3000rpm 60inch last stage blades for steam turbines. *International Journal of Gas Turbine, Propulsion and Power Systems*, 6(2), 9–16.
- [18] Naumann, H. G. (1982). Steam turbine blade design options: how to specify or upgrade. In P. E. Jenkins, *Proceedings of the 11th Turbomachinery Symposium*. Turbomachinery Laboratories, Texas A&M University.
- [19] Adegboyega, G. and Odeyemi, K. (2011). Performance Analysis of Thermal Power Station; Case Study of Egbin Power Station, Nigeria. *International Journal of Electronic and Electrical Engineering*, 281-289.
- [20] Egbin-Power, (2016). Securing Our Future; 2016 Sustainability Report. Egbin-Power, Lagos. www. <http://egbin-power.com/wp-content/uploads/2018/02/2016-Egbin-Sustainability-Report-Spread.pdf>, Accessed July 11, 2019.
- [21] Saito, E. I. J. I., Matsuno, N. A. R. I. Y. U. K. I., Tanaka, K. E. I. Z. O., Nishimoto, S. H. I. N., Yamamoto, R. Y. U. I. C. H. I. and Imano, S. H. I. N. Y. A. (2015). Latest technologies and future prospects for a new steam turbine. *Mitsubishi Heavy Industries Technical Review*, 52(2), 39–46.