

PAPER • OPEN ACCESS

Development and Prototyping of an Automated Temperature Scanner with Contact Tracing Capability

To cite this article: M O Ajewole *et al* 2021 *J. Phys.: Conf. Ser.* **2034** 012031

View the [article online](#) for updates and enhancements.

You may also like

- [Digital herd immunity and COVID-19](#)
Vir B Bulchandani, Saumya Shivam, Sanjay Moudgalya et al.
- [Remote health diagnosis and monitoring in the time of COVID-19](#)
Joachim A Behar, Chengyu Liu, Kevin Kotzen et al.
- [Analysis and control measures for Lassa fever model under socio-economic conditions](#)
O C Collins and J E Okeke



Connect with decision-makers at ECS

Accelerate sales with ECS exhibits, sponsorships, and advertising!

▶ Learn more and engage at the 244th ECS Meeting!

Development and Prototyping of an Automated Temperature Scanner with Contact Tracing Capability

M O Ajewole¹, O K Ogidan², O Babalola³ and O Oloruntoba⁴

¹ Department of Physics, Federal University of Technology, Akure, Nigeria

² Department of Electrical & Electronics Engineering, Elizade University, Ilara Mokin, Nigeria

³ Department of Computer Science, Elizade University, Ilara Mokin, Nigeria

⁴ Department of Automotive Engineering, Elizade University, Ilara Mokin, Nigeria

*e-mail: olugbengaogidan@gmail.com

Abstract. An automated temperature scanner with contact tracing capability within an organisation such as a University campus, government ministry and so on is described herein. The system is developed to assist in response to government's efforts at curtailing the spread of the novel COVID-19 pandemic and other high temperature-related diseases such as Ebola and Lassa fever. The device when installed in a premise does an automated temperature screening using its non-contact temperature sensors. It grants access only to users with temperature within the normal body temperature range (35.5 ° C to 38 ° C) and denies access to users whose temperatures are higher than the normal temperature. It performs authentication through which it acquires user's identity details such as name, sex, and address through its sensors and sends them with the acquired temperature to a remote database where the data so acquired can be further analysed. This data is useful for contact tracing, monitoring speed of diseases and for the purpose of planning / prevention of future occurrence. The developed device is incorporated with solar power which makes it usable in places with inadequate or without grid power. Being an automatic device, it functions without a human operator compared to hand-held infrared thermometer which can only be used when the screening officials are on ground. Possible application areas include University premises, schools, corporate organisations and public places such as shopping malls, hospitals to mention but a few.

1. Introduction

During the outbreak of diseases such as Ebola, Corona Virus Disease (COVID-19), Lassa fever and the likes, many countries especially in Africa lack the emergency response facilities needed to cope with such situations. Some of these facilities include adequate spaces to be used as isolation centre, test-kits for diagnosing such ailments as well as state-of-the-art facilities to monitor and track suspected carriers of the disease and carry out effective contact tracing on them. It has been found that good contact tracing mechanism helps to identify those that could have been infected while isolating them has helped to stem down the rate of spread to other people and locations. Some of the diseases that have broken out in recent years have been found to exhibit high temperature as symptoms while some infected persons might not even exhibit high temperature or any other form of symptom. Some of these high temperature – related ailments include Ebola, Lassa fever and Corona Virus Disease (COVID-19) among others. For temperature measurement during disease outbreak, non-contact temperature sensors are preferred above the contact ones in order to prevent further spread [1].



2. Literature Review

A lot of work had been done in the area of non-contact temperature technology. Applications include the field of medicine. In many cases, non-contact temperature sensors were used to acquire body temperature as a form of vital sign in the diagnosis and treatment of diseases. Some of the acquired temperature could be transmitted over the network (Internet) as a means of telemedicine [2,3,4]. Some of these temperature sensors are linked with Radio Frequency Identification (RFID) tags for the purpose of monitoring the user and their temperatures [2]. In industrial setting, non-contact temperature sensors have been used to measure temperature value of horizontal furnace to avoid unwanted readings due to thermal heating effect that could occur while using the surface-contact temperature measurement system [5]. Non-contact temperature sensors have advantages over the contact ones like the mercury in glass thermometer due to fast response compared to the contact ones [1].

In many countries in Africa, hand-held infrared thermometers comprising of non-contact temperature sensors are used in schools, motor parks and even airports to screen the populace as a means of detecting suspected infections and preventing the spread of diseases. This method is laborious and cumbersome especially when there are a lot of people to be screened. Another disadvantage of this method is that the device does not keep a record of those that have been screened including their name, address or any other form of identification. Using this method, screening can only be carried out when screening officers are available. In more advanced countries, non-contact temperature sensors in form of temperature scanning cameras are used in high pedestrian public places to screen people during a pandemic based on their body temperature. These places might include the port of entry into a country, shopping malls, train stations, hospitals and so on. It has also been found that with the use of these temperature scanners, temperature of multiple persons could be measured at the same time [5].

There are different varieties of these temperature scanners based on the technology adopted. While some of the temperature scanners use only infrared (IR) sensors [6], others have been found to combine Infrared (IR) sensor scan with thermal and colour visual imaging cameras. Many of the temperature scanners makes use of infrared sensors or thermal sensor to produce colour visualization of persons measured as well as image processing procedures for recognition of infected persons, do require the services of a professional thermographer in order to interpret the acquired data to ensure proper usage [6, 7]. In many parts of Africa where there is paucity of fund, inadequate power or even lack of grid power in some places, it becomes very difficult to implement the use of such technologies.

To effectively trace infected persons during a pandemic, there is the need for a means of detection of possible infected persons and a robust database which could be deployed in case of an emergency. This type of technology is not common in Nigeria and many African countries and as such; what is prevalent is manual contact tracing which is time consuming, cumbersome and detrimental to the whole exercise of disease control and prevention. This work therefore describes the development of a unique low cost device that leverages on existing infrastructure such as a person's identification card or biometric for identification of the user in prevention and contact tracing of possibly infected persons during temperature related pandemic. The proposed device is therefore aimed at assisting health workers through automatic temperature screening and contact tracing of suspected cases of infection in order to contain and control the spread of COVID - 19 pandemic and other temperature-related infections such as Ebola and Lassa fever. The remote logging of the user's temperature and identity into a remote database is a very important feature that makes it valuable for contact tracing in an African setting with infrastructural deficit.

3. Methodology

The developed system could be divided into the data acquisition section, control section, the actuation and output section, remote logging section and the Power and solar energy section as shown in Figure 1 and Figure 2. We shall discuss them in detail in the following subsections.

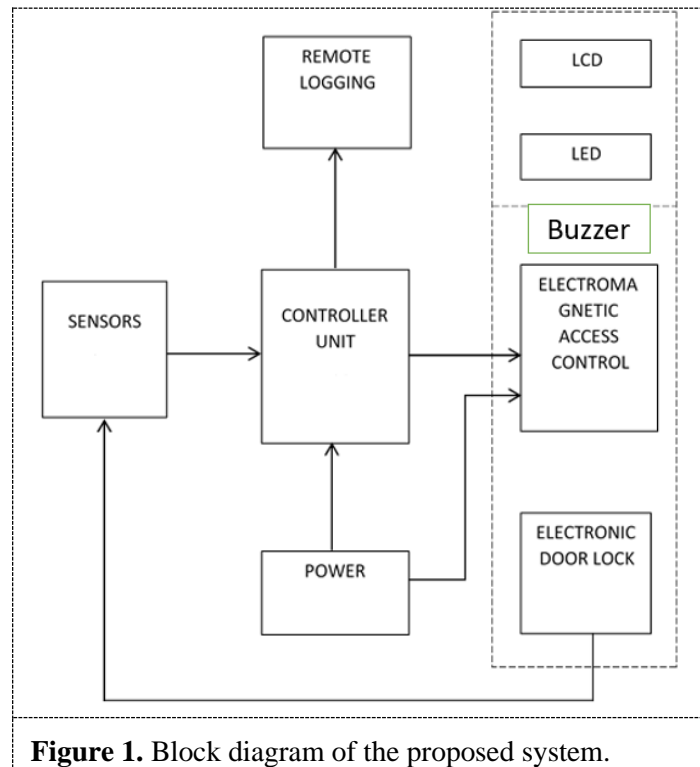

Figure 1. Block diagram of the proposed system.

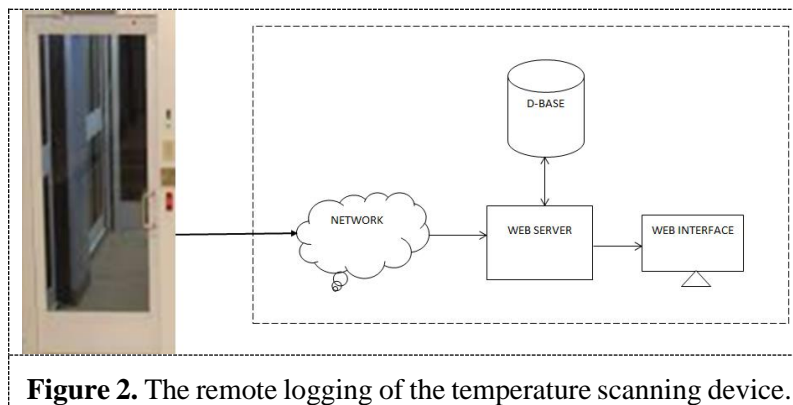
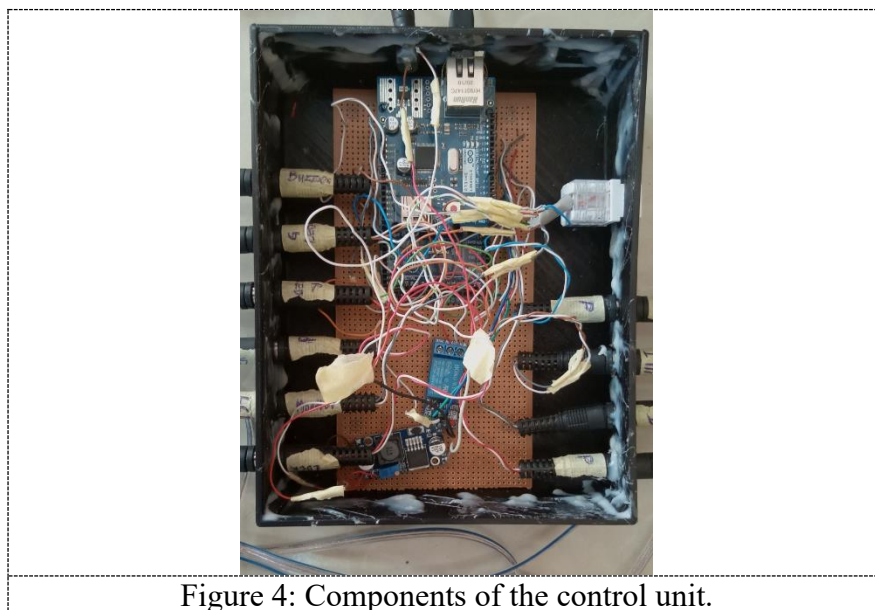
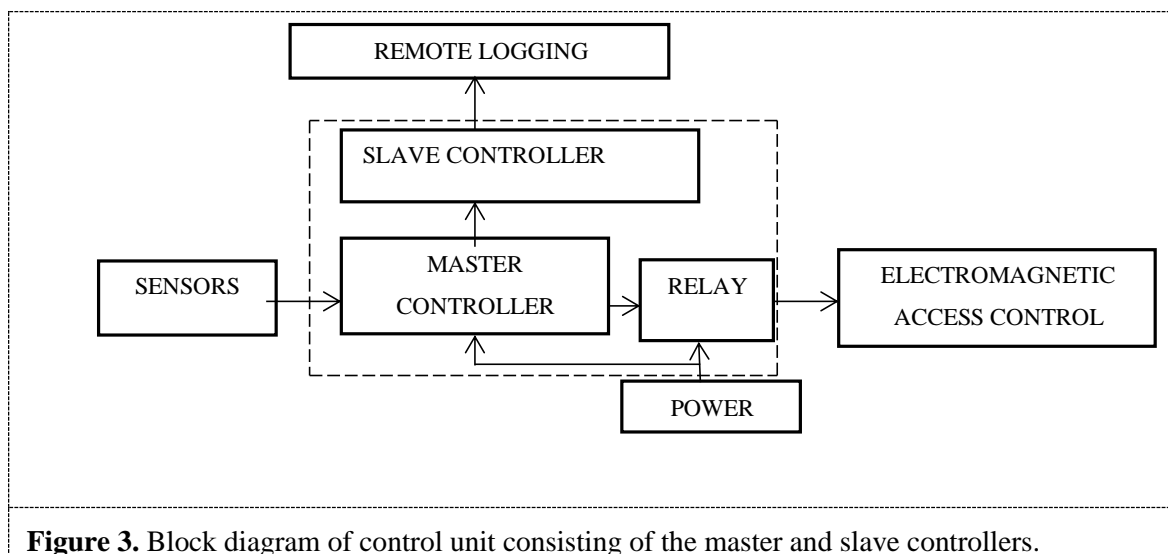

Figure 2. The remote logging of the temperature scanning device.

3.1. Data Acquisition. This consists of a sensors (contactless temperature, RFID reader, proximity sensor) which are connected to the controller. These sensors work in sequential order, for example, when a user approaches the scanner, the proximity sensor is always on to determine when a person enters into the scanning device. Once it senses that the person is maintain a close preset distance of 30 cm from the controller, it then sends signal to RFID reader and non-contact temperature sensor to perform the required data acquisition. The device prompts the user to place the RFID card on the card reader through which the reader acquires the identity details of the user through an electromagnetic wave from RFID card. He is also prompted to bring his face close to the control unit and by doing this, the non-contact temperature sensor acquires the body temperature. The data acquired from the person being scanned by the sensors are sent as information to the controller as illustrated in Figure 3.

3.2. Controller. The control unit is the coordinating unit (brain) of the temperature scanner. It is made up of the master controller, the slave controller. The master controller receives sensor values from the

sensor as shown in Figure 1. It uses the sensor values to configure its control algorithm and determine if access is granted or not. It then sends its decision through the 2-channel relay to the electronic access control which makes the door to be opened or closed depending on the temperature level of the person being scanned. Another function performed by the master controller is sending users details contained in the RFID card/tag and the acquired temperature value of the user through the slave controller which uses its wireless capability to send the information over a network (Internet) to a remote database through a web server. This is illustrated in Figure 3. Figure 4 shows the components of the control unit developed in this work while the algorithm guiding the operation of the master controller is shown in Figure 5.



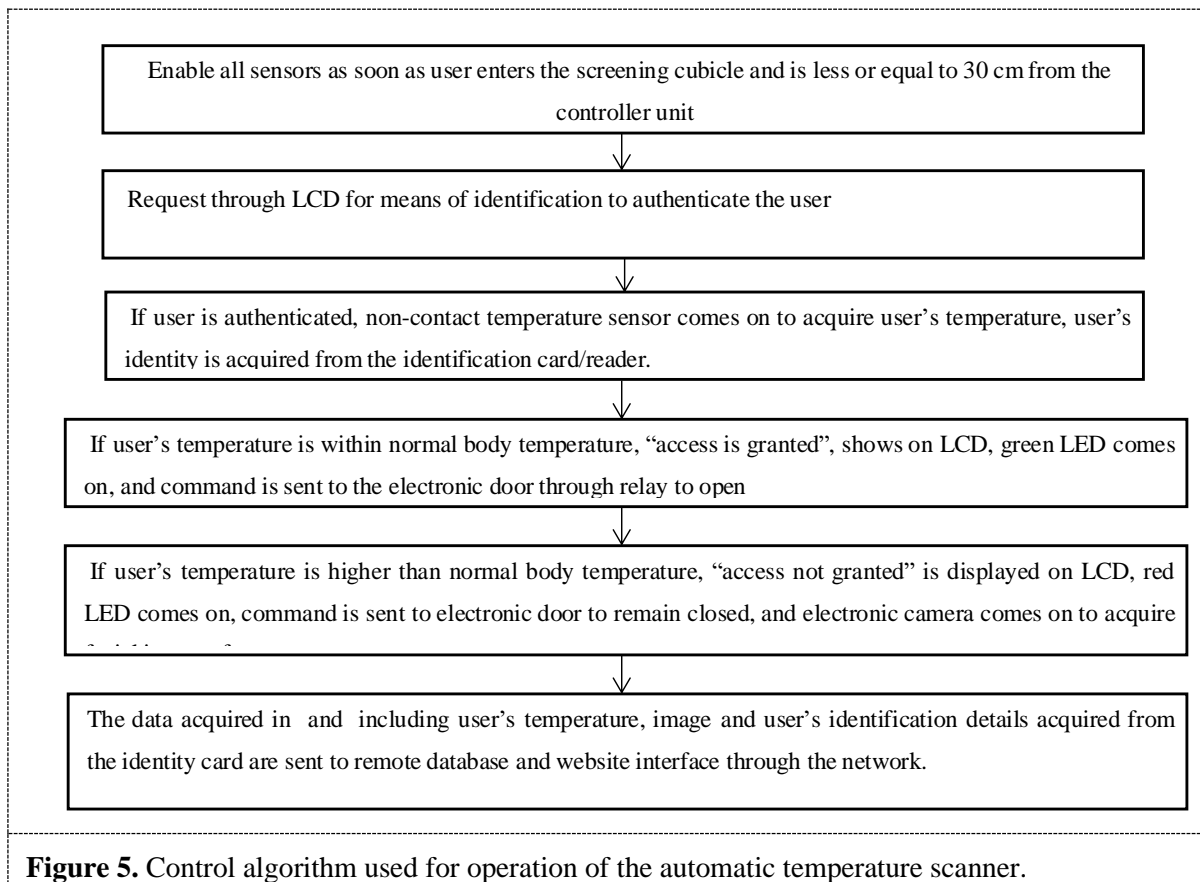

3.3. *Actuation and Output.* Figure 6 illustrates the electronic access control. This consists of Light emitting Diodes (RED LED), (GREEN LED), electromagnetic lock and the door frame. Based on the temperature level, the master controller takes its decision to grant or deny access to the user.

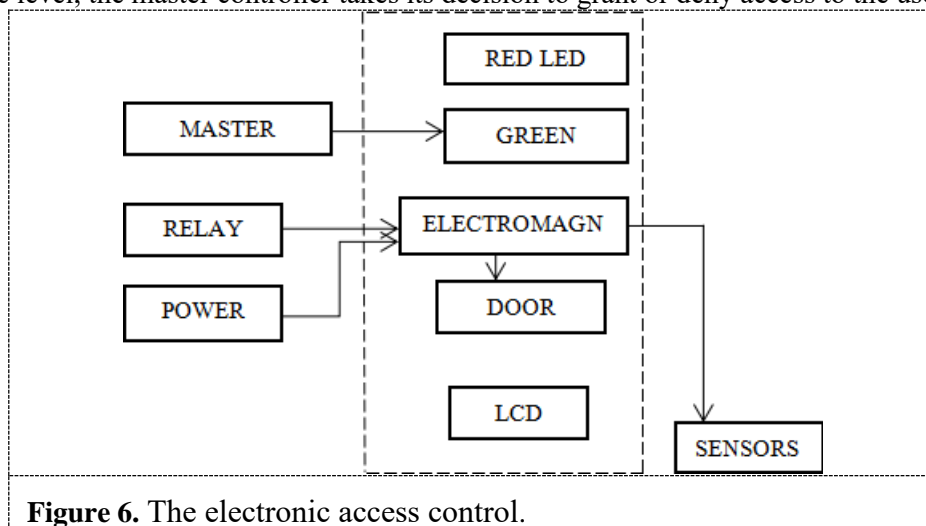

3.4. *Remote Logging.* A web-based app was developed and linked to a Webserver for remote logging of the acquired temperature and user's identity and other related information as shown in Figure 7.

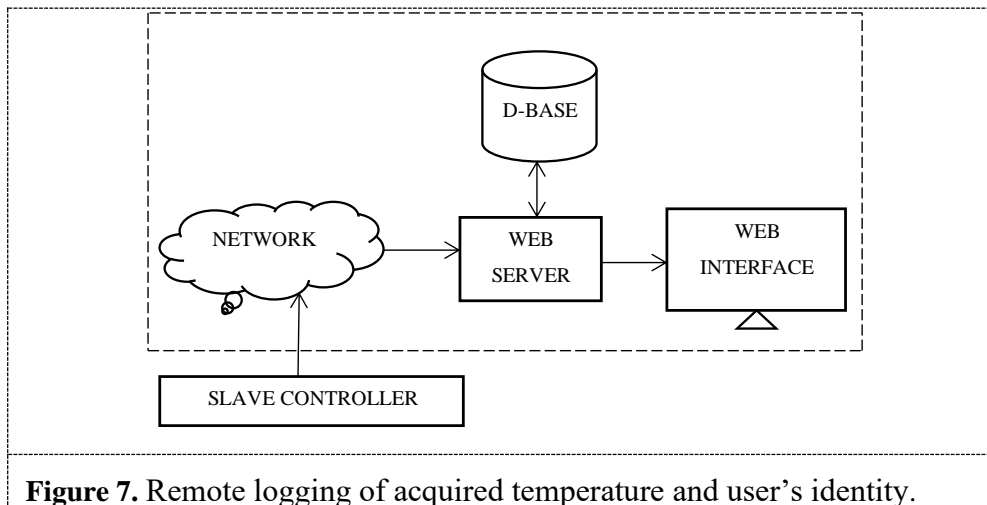

3.5. *Solar Power Option.* In order to avoid down time, an alternate solar power was incorporated into the temperature scanner so that it could complement grid power (AC/DC). With this solar back-up, the device is able to automatically alternate between grid and solar power so ensure uninterrupted supply of power. The power system (grid/solar) supplies 12 Volts to the microcontroller, relay and the electronic lock. The power sources and connections are illustrated in Figure 8.

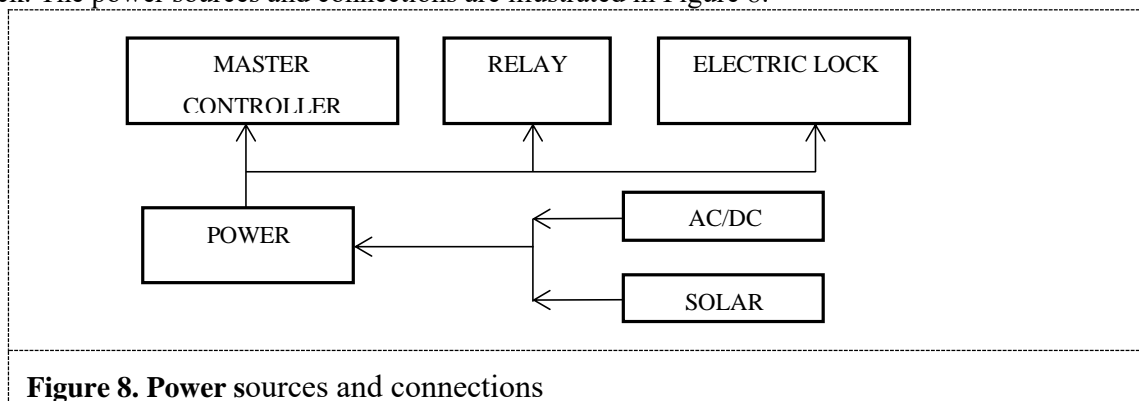

4. Result and discussion

Tests were carried out on the temperature scanning device.

If the measured temperature is normal (35.5 o C to 38 o C), it sends a signal to the electromagnetic access control that grants access to the user. At the same time, access granted is displayed on the LCD while the green LED comes on. If temperature is higher than normal, it ensures access is denied to the user, access denied is displayed on LCD while the red LED comes. The system also ensured that user’s temperature and identity details are sent to the remote database/webpage via remote logging module for record purpose as illustrated in Figure 2.

If access is granted, the master controller sends appropriate signal to the relay which switches the electromagnetic lock to open the door, buzzer sounds an alarm, green LED comes on, LCD displays “access granted”. If access is not granted, the corresponding signal is sent to relay which switches the electromagnetic lock, red LED comes on, buzzer sounds an alarm, while the LCD display “access denied”. The electronic lock receives its power from the power supply.

These were later displayed on a secured webpage accessible only to the authorized stakeholders as shown in figure 10. The sensor information received by the master controller was sent via the slave controller over the network. The slave controller was a Node MCU microcontroller with inbuilt Wi-Fi module. This made it possible for the sensor information to reach the web server and by extension, the online MySQL data-base. From the online data-base, the system administrator or health care officers

are able to have access information of the persons scanned by the system including their identification detail, the date and time of scans and so on through a web interface as shown in Figure 10. The prototype of the developed temperature scanner was placed at the Entrance of the Faculty of Basic and Applied Sciences, Elizade University as shown in Figures 9a and 9b and used for temperature screening. Figure 10 is a secured web portal being implemented on a Local Area Network (LAN) to display the temperature of users, name, sex, time and date of temperature measurement.

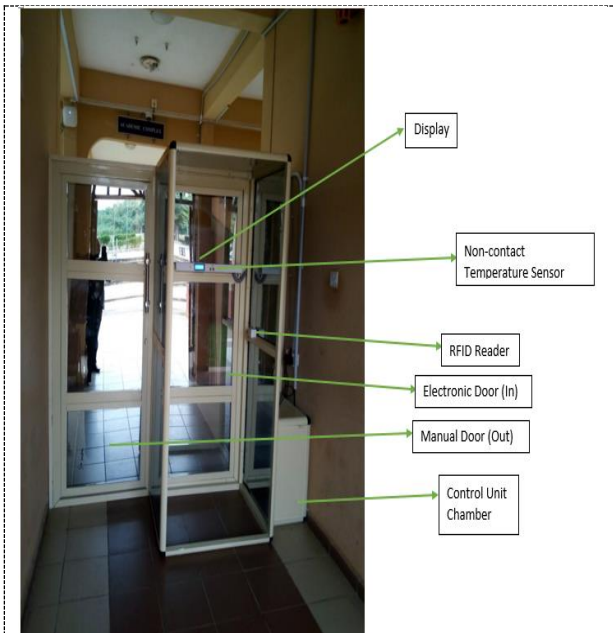

Figure 9a. Temperature scanner prototype.



Figure 9b. Temperature scanner installed at the entrance of the Faculty building, Elizade University (from the rear).

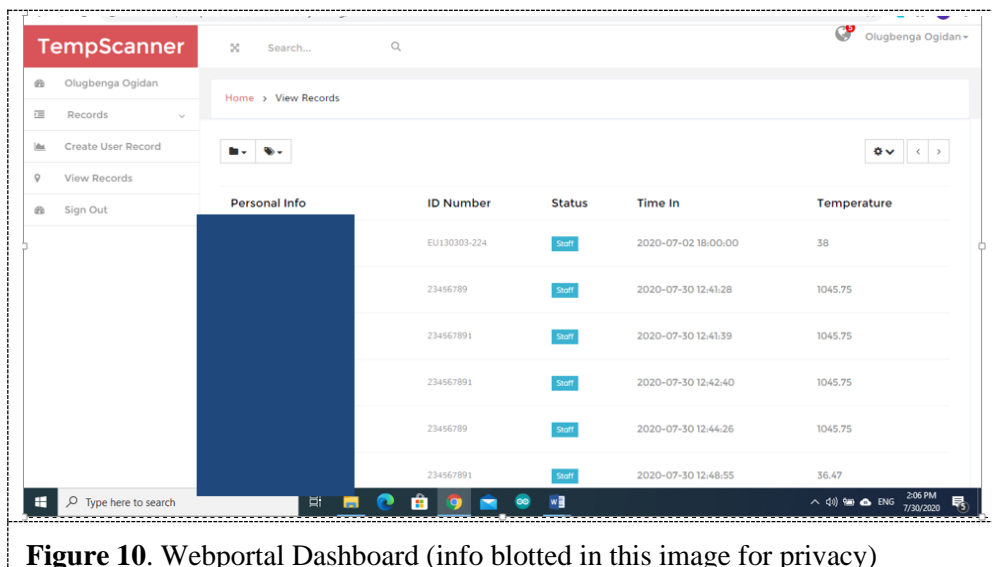

Figure 10. Webportal Dashboard (info blotted in this image for privacy)

5. Conclusion

In this work, an automated temperature scanner with contact-tracing capability is developed that automatically performs temperature scanning whether the health officials are available or not, grants access to a premises to only persons within the safe temperature range thereby preventing the rate of spread of possible infection. The system automatically logs the temperature/identity of persons scanned to a remote database and made available to health officials via a secured web interface. This could be used for contact tracing, evaluation of the rate/pattern of disease spread and for planning purposes. The system would work best within an organization such a University campus, government ministry, corporate organization and so on. Future work would include the incorporating a google-based contact tracing capability such that it could be used to trace where people have been to for a period of about 1 month.

6. Acknowledgements

This research was supported by Nigeria Communications Commission through her Research Grant Award for Digital Solutions to COVID 19 in Nigeria, 2020.

References

- [1] Long G 2016 Design of a Non-Contact Infrared Thermometer. *International Journal on Smart Sensing & Intelligent Systems*. **9**(2).
- [2] Vaz A, Ubarretxena A, Zalbide I, Pardo D, Solar H, Garcia-Alonso A, & Berenguer R 2010 Full passive UHF tag with a temperature sensor suitable for human body temperature monitoring. *IEEE Transactions on Circuits and Systems II: Express Briefs*. **57**(2), 95-99.
- [3] Özgören M, Şakar M, and Öñiz A 2010 Contact/non-contact sensor mesh for body temperature monitoring. In *2010 15th National Biomedical Engineering Meeting* (pp. 1-4). IEEE.
- [4] Costin H, and Rotariu C 2018 Vital Signs Telemonitoring by Using Smart Body Area Networks, Mobile Devices and Advanced Signal Processing. In *Advances in Biomedical Informatics Springer, Cham*. (pp. 219-246).
- [5] Bej D 2017 *THESIS APPROVAL* (Doctoral dissertation, Institute of Technical Education & Research, Siksha'O'Anusandhan University).
- [6] Clearway 2020 <https://www.clearway.co.uk/our-services/body-temperature-detection-camera/>, accessed 15/05/2020.
- [7] Infraredcameras 2020 <https://infraredcameras.com/applications/medical/infrared-temperature-scanners/>, accessed 15/05/2020.