



Potentials for generating alternative fuels from empty palm fruit bunches by pyrolysis

^{1*}Ogunsina, B.S; ²Ojolo S.J; ³Ohunakin, O.S; ¹Oyedeji, O.A; ⁴Matanmi, K.A and ⁵Bamgboye, I.A

¹Dept. of Agricultural & Environmental Engineering, Obafemi Awolowo University, Ile-Ife. Nigeria

²Dept. of Mechanical Engineering, University of Lagos. Nigeria

³Dept. of Mechanical Engineering, Covenant University, Ota, Nigeria

⁴Dept. of Mechanical Engineering, Obafemi Awolowo University, Ile-Ife. Nigeria

⁵Dept. of Agricultural & Environmental Engineering, Obafemi Awolowo University, Ile-Ife. Nigeria

Abstract

The threat that the disposal of empty palm fruit bunches constitute to communities in oil palm processing areas in Nigeria coupled with the current global focus on alternative energy is the trigger for this work. An existing pyrolytic reactor consisting of a reactor unit, condensate receiver, copper pipe connectors and gas receiver was modified and adapted for converting empty palm fruit bunches to alternative fuels. The average char yield was 44.9%, and the percentage of feedstock converted into pyrogas and tar oil was 55.1%. The char yield decreased gradually as temperature was increased from 300-700°C. Char yield was highest (39.78%) when the temperature was 300°C and the lowest char yield was 25.05% at 700°C. The calorific values of char ranged between 21.12 and 23.76 MJ/kg. Apart from the potential of generating energy from pyrolysed EFB, it abates the disposal problem that EFB constitutes in the oil palm industry.

Keywords: Empty Palm Fruit Bunches, Thermo-Chemical conversion, Alternative Fuel, Char, Pyrogas, Tar Oil

1. Introduction

With the continual depletion of fossil fuel reserves and increasing global concerns over climate change, Nigeria as a foremost country in sub-Sahara Africa (like other regions of the world) is faced with the need to explore alternative energy sources. One of the known approaches is the conversion of biomass into alternative fuels by pyrolysis. Pyrolytic conversion of organic wastes apart from generating alternative energy is an efficient way to eliminate emission of odour from disposed solid wastes. The biomass is converted into a black carbonaceous solid, a mixture of gases and tar oil; the proportion of which depends on composition of the biomass, temperature and duration of the process. Soltes (1986) documented that tar oil may be fractionated into gasoline and diesel fuels to run engines; and may also be processed as disinfectant, germicides and wood preservatives while the gasses may be used for powering internal combustion engines or processed into liquid fuels. Pyrolysis has received considerable attention as a method for waste disposal in an environmentally acceptable manner with

remarkable resource recovery at the same time (Piechura, 1998). Several works have been documented regarding pyrolytic conversion of bulky agricultural wastes into alternative energy sources (Misson, 2009, Abdullah and Gerhauser, 2008; Ojolo, *et al.*, 2008; Bamgboye and Oniya, 2003; Ojolo and Bamgboye, 2005). Sukiran *et al.* (2009) documented a pyrolytic process for pulverised EFB under varied conditions in a fluidized fixed-bed reactor. Bamgboye and Oniya (2003) reported that pyrolytic conversion of corncobs to medium grade fuels and chemical preservatives yielded pyrogas, tar oil, pyroligenous acid and tar with about 91.49% conversion efficiency. The studies of Ojolo and Bamgboye (2005) on the thermo-chemical conversion of municipal solid wastes to produce fuel and reduce waste shows that municipal solid wastes when pyrolysed can be converted into useful fuel products such as tar oil, pyrogas and char. Barnerd and Gerald (1983) reported how pyrolytic systems are developed and used to power road vehicles during the second world war. The process is being used in Netherlands and USA to recycle plastic waste and shred rubbish (Westerhent *et al.*, 1988). Ogunsina *et al.* (2008) investigated



the pyrolytic conversion of cashew nut shells into bio-fuels; the disposal of which has hitherto being a serious menace in the cashew nut processing industry.

In Africa and Asia, widespread cultivation of oil palm (*Elaeis guineensis*) is driven by the vegetable and industrial oils (*i.e* palm oil and palm kernel oil respectively) that its fruits provide. Presently, Nigeria ranks third among the largest producers of palm oil in the world after Malaysia and Indonesia; although the industry is largely concentrated in rural communities where processing is by manual or semi-manual methods (Salako *et al.*, 2009). The major unit operations include reception of the palm fruits bunch, sterilization, threshing, digestion, pulp pressing, oil clarification, nut recovery, oil and nut drying. Considerable amount of biomass such as the mesocarp fibre, shell, empty fruit bunches (EFB), frond, trunk and palm oil mill effluent are generated in each unit at different stages but EFB is usually the bulkiest. In Nigeria up till now, EFB is still being incinerated due to the dearth of information regarding its potentials as a source of alternative fuels.

In this work, an existing pyrolytic reactor by Ojolo and Bamgboye (2005) was modified and tested to investigate the potentials of converting EFB to alternative fuels.

2. MATERIALS AND METHODS

2.1 Materials

The following materials and equipment were used for this investigation: weighing machine, oven, pyrolytic reactor, stop watch, EFB, cutlass (for disintegrating the EFB bunches into smaller chunks) and attrition mill. About 20 kg of dried (18.8% moisture content) EFB were collected from Seldot palm oil mill, Gbongan, Osun State, Nigeria. The EFB were kept in polythene bags until when needed to prevent moisture loss.

2.2 Description and limitations of the existing pyrolytic reactor

The existing design is composed of a furnace which encloses a retort, a gas holder and condensate receiver (Fig. 1). The retort was connected to the condensing unit with copper pipes. The reactor was made of 1.6 mm thick mild steel into a cylinder of 5 dm³ volume with a

sealed bottom. A 3000 W capacity heating element connected to a 220 V single phase power source was placed at the bottom of the reactor. The reactor was fully lagged with fibre glass to prevent heat loss by radiation. A 1200 °C thermostat was installed inside the heating chamber for temperature control using a bimetallic material incorporated inside the heating chamber to monitor the resident time and heating rate of the feedstock. The condensate receiver was a mild steel container placed on a bed of ice; it condenses the tar oil from the mixture of gases conveyed from the reactor while the tar gas is further conveyed to the gases receiver through the lagged copper pipe. The gasses receiver is made of glass with a cork to prevent heat loss. The reactor had been tested with corn cobs and cashew nut shells; however with EFB, the system was unable to withstand the high pressure generated at temperatures above 650 °C and the backflow of pyrogas into the condensate receiver could not be prevented.

2.3 Design modifications

The functional elements of the modified unit are the reactor chamber, condensate receiver, copper pipes and gas receiver. A clip and a high heat resistance gasket were introduced to constitute an improved air tight cover that disallows leakage in and out of the container. A non-return flow valve controlled by gas pressure was in between the gas receiver and the condensate receiver. The valve poppet opens to allow gas passage to the receiver when the gas pressure rises above 35 kPa and does not allow a backward flow.

2.4 Machine testing

The EFB which had an average moisture content of 18.8 % (wb) were chopped into small particles and milled. The particle sizes used were between 100 -150 µm. The reactor was then loaded in batches with 300 g, 370 g, 360 g, 350 g and 400 g of EFB and allowed to operate for 9 h at an average temperature 550 °C each run in triplicates. The weight of the char after the thermo-chemical reaction was measured and recorded; the char yield was calculated as in eqn.1. The percentage of char produced was also calculated using eqn. 1. Tar oil produced was collected after distillation in the condensate receiver and the gas produced was collected in the gas receiver.



$$Y_c = \frac{W_c}{W_w} \times 100\% \quad 1$$

where, Y_c = Char yield

W_c = Weight of char after pyrolysis

W_w = Weight of feedstock.

The percentage of empty fruit bunches used up during the investigation was calculated as follows:

$$\% \text{ of EFB used} = \frac{W_w - W_c}{W_w} \times 100\% \quad 2$$

2.4 Pyrolysis of EFB

The reactor was used to pyrolyse EFB at five different temperature levels: 300, 400, 400, 500, 600 and 700°C selected based on review of literatures. With each temperature level, there were three replicates of the experiment. The calorific values of the char produced during each temperature trial were determined using Gallenkamp ballistic bomb calorimeter (Cambridge Instrument Co. Ltd., England) and ultimate analysis was carried out as documented by Ogunsina *et al.* (2009).

3. RESULTS AND DISCUSSIONS

The schematic drawing of the modified reactor is shown in Fig. 2. The performance test showed noticeable gaseous emission after the first 2 h into the experiment. After 4 h, some pyrogas were observed in the gas receiver and an insignificant amount of tar oil was observed in the tar oil receiver. At the end of each experimental run, there was reduction in the weight of the empty fruit bunch loaded at the start of the experiment. The resulting char yield during each run is presented in Table 1. With an average char yield of 44.9%, the percentage of EFB converted in pyrolytic products was 55.1%. Beside the potential for generating energy from EFB the reduction in the bulk offers solution to the problem that the disposal of EFB constitute in the oil palm industry.

Table 2 shows the average yield of pyrolytic products at different temperature. The char yield decreased gradually as temperature was increased from 300-700°C. Char yield was highest (39.78%) when the temperature was

300°C and the lowest char yield was 25.05% at 700°C. It was however observed that the yield of other pyrolytic products increased with temperature.

Table 3 shows the ultimate analysis and calorific value including the H/C and O/C molar ratios of pyrolysed EFB products at different temperatures. The values do not depict a definite trend but showed little differences. The calorific values of char based on the different temperatures considered in this work ranged between 21.12 and 23.76 MJ/kg. Although the calorific values also do not show a definite trend, the highest was 23.76 MJ/kg when pyrolysis temperature of 500°C. The H/C ratios of char changed between 0.50 and 0.65. The highest H/C ratio of char was 0.65 when the pyrolysis temperature was 400°C. The O/C ratios of the EFB char ranged between 0.37 and 0.55. The highest O/C ratio of char obtained was 0.55 when pyrolysis temperature was 700°C. The percentage range of hydrogen and nitrogen were 3.01 - 4.17% and 1.98 - 2.68% respectively. The highest hydrogen and nitrogen content obtained were 4.17% and 2.68% at pyrolytic temperatures of 400°C in both cases.

4. Conclusion

From the foregoing, it may be concluded that:

- 1) An existing pyrolytic reactor was modified and adapted for converting empty palm fruit bunches to alternative fuels. A clip and a high heat resistance gasket were introduced to constitute an improved air tight cover that disallows leakage in and out of the container. A non-return flow valve controlled by gas pressure was placed in between the gas receiver and the condensate receiver. The valve poppet opens to allow gas passage to the receiver when the gas pressure rises above 35 kPa and does not allow a backward flow.
- 2) Empty palm fruit bunches may be converted to char, tar oil and pyrogas by pyrolysis. The percentage of char produced was 44.9%; about 55.1% of the feedstock was converted to tar oil and pyrogas.
- 3) Char yield decreased gradually as temperature was increased from 300-700°C. Char yield was highest (39.78%)



when the temperature was 300°C and the lowest char yield was 25.05% at 700°C. The calorific values of char ranged between 21.12 and 23.76 MJ/kg.

- 4) Utilization of EFB as feedstock for energy generation by pyrolysis will help in abating EFB disposal problems in oil palm mills.

References

- Abdullah, N. and Gerhauser, H. 2008. Bio-oil derived from empty fruit bunches. *Fuel* 87(12): 2606–2613.
- Bamgboye, A.I. and Oniya, O. 2003. Pyrolytic Conversion of corncobs to medium grade fuels and chemical preservatives. *Journal of Environment and Engineering Technology*, Federal University of Technology, Akure, Nigeria. 3(2)50-53.
- Barnerd, G. and Gerald, F. 1983. Biomass Gasification in Developing Countries. Earthscan International Institute for Environment and Development, London
- Misson, M; Haron, R; Fadhzir, M; Kamaroddin, A; Aishah, N and Amin, S. 2009. Pretreatment of empty palm fruit bunch for production of chemicals via catalytic pyrolysis. *Bioresource Technology*, 100: 2867–2873
- Ojolo, S.J and Bamgboye, A.I. 2005. Thermochemical conversion of municipal solid waste to produce fuel and reduce waste. *Agricultural Engineering International- The CIGR EJournal*. Vol. VII. Manuscript EE 05 006. September, 2005.
- Ojolo, S.J; Bamgboye, A.I; Ogunsina, B.S and Oke, A. 2008. Analytical approach for predicting biogas generation in a municipal solid waste anaerobic digester. *Iranian Journal of Environmental Health Sciences and Engineering*, 5(3):179-186.
- Ogunsina, B.S; Ojolo S.J.; Bamgboye A.I.; Muritala A.O.; Fasogbon S.K.; Femi-Falade O. and Imodu D.E. 2009. Thermochemical Conversion of Cashew Nut (*Anacardium Occidentale*) Shells into Alternative Energy Sources. Proceedings of the 3rd International Conference of the West African Society for Agricultural Engineering & 9th Nigerian Institution of Agricultural Engineers Conference held at Obafemi Awolowo University, Ile Ife, NIGERIA. Jan. 25-29, 2009, pp 339-343
- Piechura, H. 1998. *Pyrolytic Technology Applications. Hazardous Waste Detection, Control, Treatment*. Elsevier Science Publishers. B.V. Amsterdam, Netherlands. Pp 1335-1343
- Soltes, E.I. 1986. Thermochemical Process for Bio-Energy Production. *Biomass Energy Development*. Plenum Press, New York
- Sukiran, M.A; Kheang, L.S; Abu Bakar, N and May, C.Y. 2011. Production and characterization of Bio-Char from the Pyrolysis of Empty Fruit Bunches. *American Journal of Applied Sciences*, 8 (10): 984-988
- Salako, Y.A; Owolarafe, O.K. and Anozie, A.N. 2009. Characterisation of sundried palm fruit waste biomass materials. *Ife Journal of Technology*, 18(2): 26-30.
- Westerhent, R.W.; Wanders J. and Kuipers J.A.M. 1988. The development of a continuous rotation cone reactor pilot plant for the pyrolysis of polythene and polypropane. Industrial and Engineering Chemistry Research. *American Chemical Society*. U.S.A. 37(6): 2316-2327.

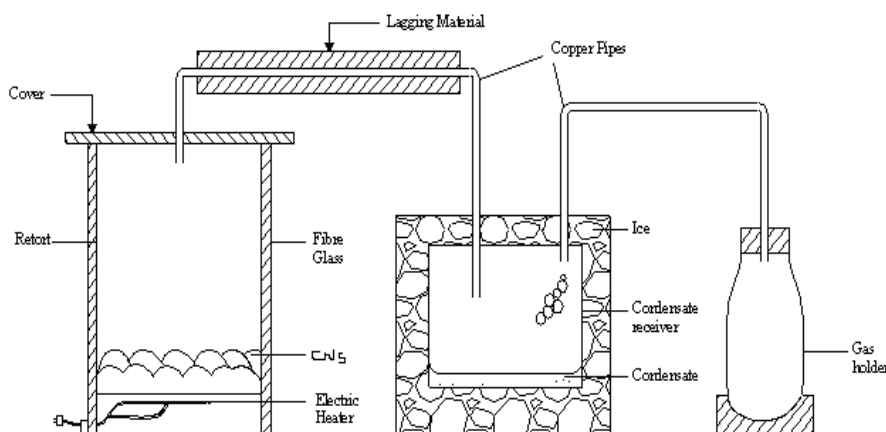
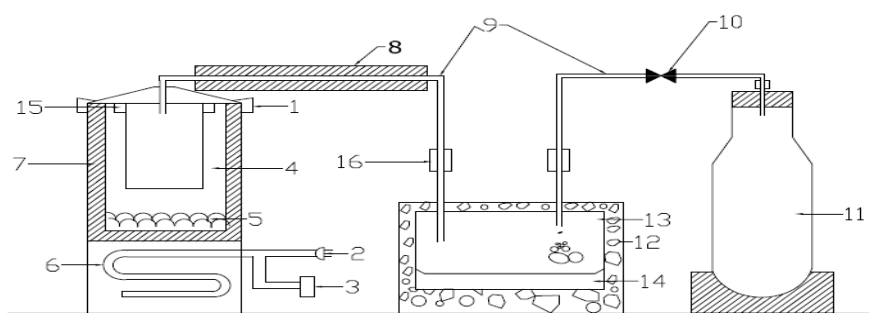

Fig. 1. Previous design of pyrolytic reactor
(Source: Ojolo and Bamgboye, 2005)



1 -Clip; 2 -Power source; 3 -Temperature control unit; 4 -pyrolytic reactor; 5 -EFB; 6 -Heating element; 7 -Fibre glass; 8-Lagging; 9 -Copper pipes; 10 -Non-return valve; 11 -Gas holder; 12 -Ice block; 13 -Condensate receiver; 14 -Tar oil; 15-Gasket; 16-Connector.

Fig. 2. The modified pyrolytic reactor design

Table 1: Char yield from the pyrolysed product

Replicates	Initial weight of EFB	Final weight of EFB	% Char yield
A	300	135	45.0
B	370	160	43.24
C	360	170	47.22
D	350	150	42.86
E	400	185	46.25
MEAN (SD)			44.9 (1.88)

Table 2. Average yield of pyrolytic products at different temperatures

Temperature (°C)	Yield (%)		
	Tar-oil	Char	Gas



300	27.9	39.78	32.32
400	32.12	27.8	40.08
500	29.98	27.19	42.83
600	31.92	26.22	41.86
700	33.61	25.05	41.34

Table 3. Properties of EFB char produced at different temperature

Pyrolytic temperature (°C)	Ultimate analysis						Calorific value (MJ/kg)
	C (wt. %)	H (wt. %)	N (wt. %)	O (wt. %) by diff.	O/C Molar ratio	H/C Molar ratio	
300	68.67	3.46	2.32	25.55	0.37	0.50	23.67
400	64.10	4.17	2.68	29.05	0.45	0.65	21.12
500	66.95	3.99	1.98	27.08	0.40	0.60	23.76
600	65.32	4.01	2.13	28.54	0.44	0.61	23.1
700	60.88	3.50	2.11	33.51	0.55	0.58	24.04