

Design of Intel 8751 Microcontroller-based System for Monitoring and Control of a Thermal Process

Francis Enejo Idachaba

Department of Electrical and Information Engineering, College of Science and Technology, Covenant University Ota, Ogun State, Nigeria

ABSTRACT

An Intel 8751 microcontroller-based system was developed to monitor and control the temperature of an oven. The IN4148 signal diode was used as the temperature sensor and the on-off control algorithm was utilized with the system switching off the heating process whenever it attains the preset value. The system provides a digital readout of the system temperature and a status/blinker indicator showing whether heating is in progress or terminated. The control programs were loaded onto the memory of the microcontroller and the enable the selection of the different temperature values. The system improves accuracy by eliminating human participation and saves operator time. The system is easy to operate, maintain, and upgrade.

Keywords:

EPROM, Intel 8751, On-Off control, Temperature sensor.

1. INTRODUCTION

Industrial processes are pivotal in the advancement of technology. These processes over time have been refined from manually controlled systems to automated computer controlled systems. This has led to more efficient manufacturing processes with very high precision levels [1].

Physical processes require measurement of the variables involved in the processes and the control of these processes based on the measured variables. Examples of these variables include temperature, flow rate, pressure, etc.

A combination of measurement and control can only be achieved when a form of intelligence is introduced. Intelligent instrumentation can thus be defined as the use of a measurement system to evaluate a physical variable employing usually a microprocessor/microcontroller-based system to perform the information processing [1, 2]. The result of the information processing can then be used to control the physical process based on the stored program in the system memory.

1.1 System Description

The block diagram of the temperature monitoring and control system is shown in Figure 1. The system hardware consists of a signal diode (1N4148), a differential amplifier, a flash comparator analog to digital converter, the Intel 8751 microcontroller, seven segment display interfaced to the microcontroller to enable the display of the set (desired) temperature (ST), and process temperature (PT), which is from 25°C to 99°C. Other

circuits are introduced for the blinker and heater system control. The keypad serves as the input device for the ST.

1.2 Software System

The software governing the operation of the system was developed in assembly language and then compiled before being loaded onto the onboard erasable programmable read only memory (EPROM). The algorithm utilized is listed below.

1. Initialize ports
2. ST
3. Sample PT
4. Compare ST and PT
5. If $ST > PT$ then continue heating
6. If $ST = PT$ turn off the heater

The flow chart for the system is shown in Figure 2.

1.3 The Transducer Circuit

The general purpose silicon diode IN4148 was used as the sensor as shown in Figure 3.

The 1N4148 signal diode generates a forward voltage of approximately 600 mV when a fixed current of 1v mA is passed through it [3].

The Zener diode is used to maintain a fixed voltage across the diode such that any variation in the current flowing through the diode will be due to the external fluctuation in temperature, which is converted to voltage by the diode's $-2 \text{ mV}/^\circ\text{C}$ temperature coefficient. This negative coefficient leads to the generation of a voltage with

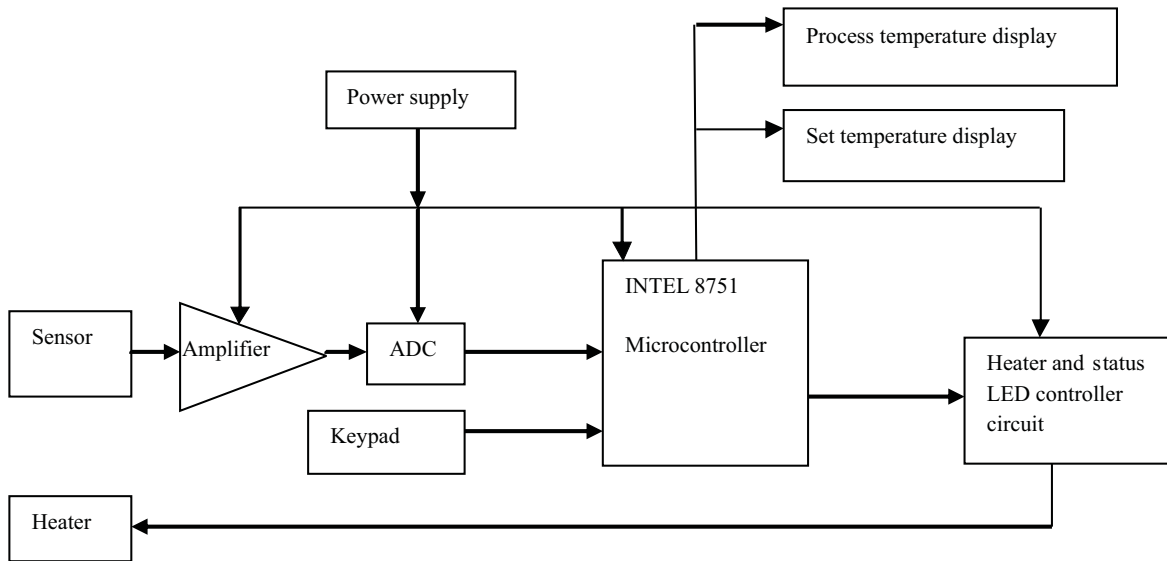
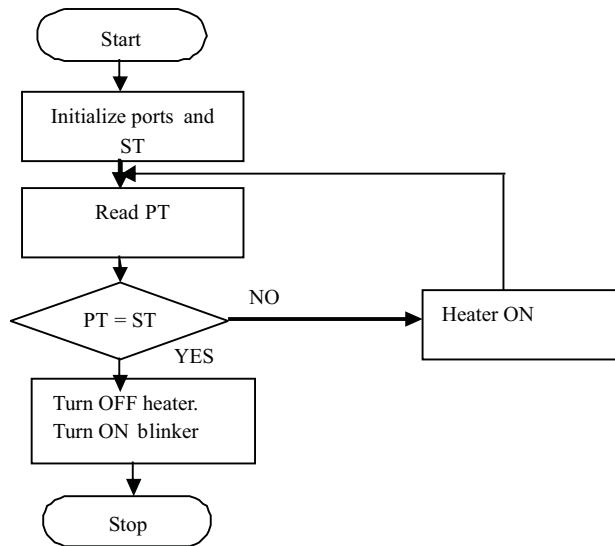

Figure 1: Block diagram of the temperature monitoring and control system.



ST: Set temperature; PT: Process temperature

Figure 2: System flow chart.

negative slope. This voltage is amplified and inverted by the succeeding stages of operational amplifiers connected to the sensor circuit.

1.4 Microcontroller and ADC

The Intel 8751 has four 8-bit ports, which can be used for data transfer to and from the microcontroller [4]. The system is designed for a temperature range of 25°C–99°C. Within this range, the temperature is sampled at 5°C interval giving a total of 16 discrete readings. The parallel comparator ADC is used for conversion of the sensor output from the analog format to a digital format [5]. Sixteen operational amplifiers in four LM 324 chips are used to implement the parallel comparator ADC [6, 7]. With the microcontroller being an 8-bit chip, the temperature ranges were divided into 8-bit ranges with the lower 8 bit (25°C–60°C being labeled as low temperature and 65°C–99°C being labeled as high temperature). The outputs of the different

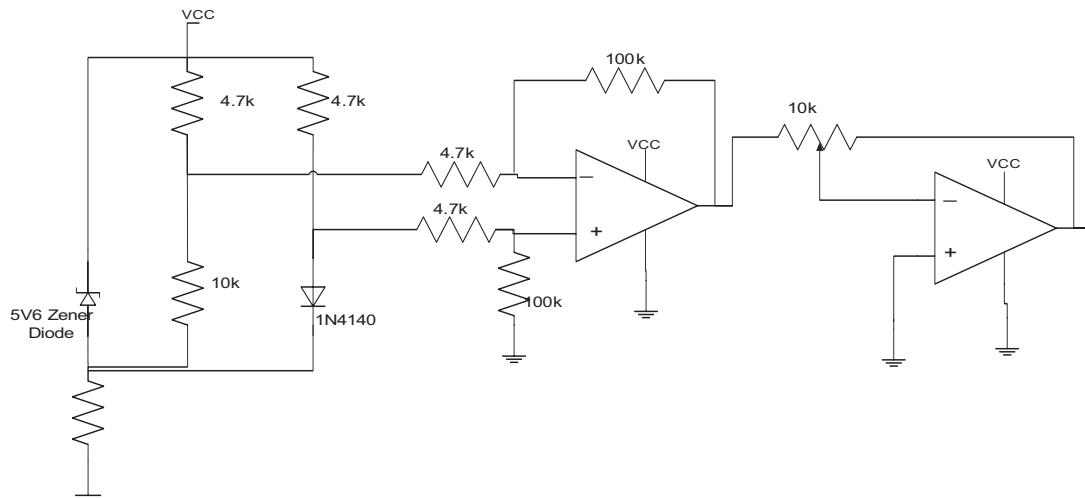

Figure 3: The transducer circuit.

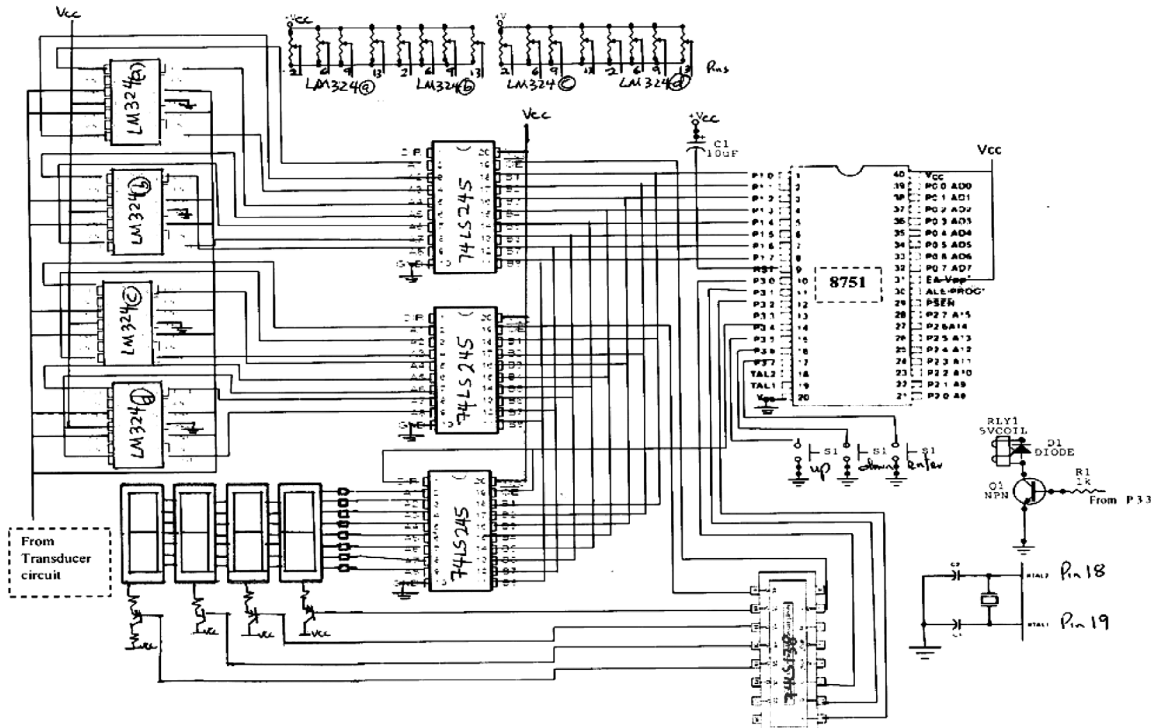

Figure 4: Main board showing the Microcontroller, the ADC circuit, the 74LS245, 74LS138 chips and the seven segment displays.

op-amps are fed to port 1 of the microcontroller using the Tristate 74LS245 octal bus transceivers. The use of the transceivers is to enable the selection of the required range of temperatures to be transmitted to the microcontroller since the microcontroller ports can access only 8 bits at a time. The selection of the desired range access to be read is determined by the activation of the 74LS245 bus transceiver, and this is achieved by the use of the 74LS138 1-8 demultiplexer.

The control program was stored in the onboard EPROM. Port 1 of the microcontroller with the aid of latches (74LS245) serves as the input port for low and high temperatures, and as an output port for driving the seven-segment display. This eliminates the need for a display driver for the seven-segment display.

The port 3 pins addressing capabilities are enhanced by the use of the 74LS138, which increases the addressable pins of the microcontroller. The other pins in port 3 are assigned the up, down, and enter push buttons and the relay. Port 0 and 2 are used for accessing external memory and these pins are unconnected since no external memory is used. The pins 29 and 30 are also left unconnected due to the nonutilization of external memory. The circuit is shown in Figure 4.

1.5 Control Electronics for Heater and Blinker Circuits

The control electronics is responsible for the actual ON-

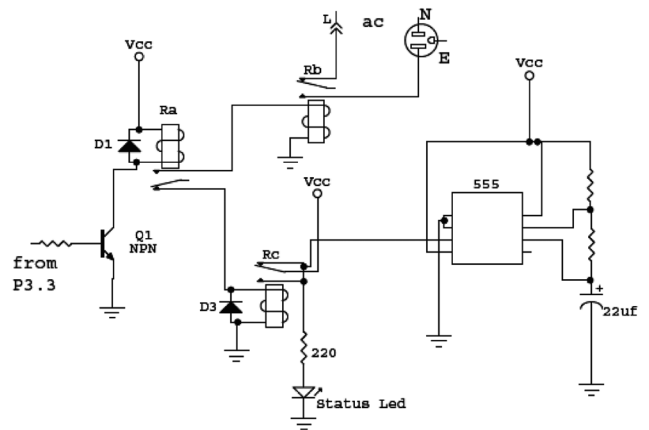

Figure 5: Controller for heater and blinker circuits.

OFF switching of the heater, the status indicator and the blinker circuits. The circuit is given in Figure 5.

1.6 Switching/Indicator Algorithm for the Heater/ Blinker Controller Circuit

1. At power on, Ra and Rb are de-energized.
2. Rc is energized through the normally closed contact of Ra.
3. With Rc energized, the status Light Emitting Diode (LED) stays on.
4. With ST entered, Ra is energized.
5. Rb is also energized through the normally open contact of Ra; this switches ON the heater.

Table 1: Temperature and corresponding voltage reading at the transducer and inverter output

Temperature (°C)	Transducer output voltage (V)	Inverter output (V)
25	3.96	1.31
30	3.92	1.32
35	3.83	1.33
40	3.69	1.35
45	3.55	1.39
50	3.40	1.43
55	3.24	1.48
60	3.05	1.53
65	2.86	1.59
70	2.67	1.64
75	2.47	1.70
80	2.27	1.76
85	2.05	1.82
90	1.76	1.90
95	1.49	1.99
99	1.33	2.04

- Rc is de-energized as it is connected to closed contact of Ra, which is now open.
- The status LED is connected to the astable multivibrator, which flashes at 0.73 Hz, indicating that heating is in progress.
- When ST equals PT, the Ra is de-energized by the microcontroller via P3.3. and this de-energizes Rb switching off the heater.
- The Rc is energized and status LED stays on, indicating standby mode.

2. RESULTS AND DISCUSSION

During the development stages, the various units of the hardware were evaluated individually and as an integrated unit. The software was also tested using the A51 macroassemblers. All the errors found were corrected and the system was tested using several water heating cycles and a mercury thermometer for temperature measurement. The system was calibrated and the results are shown in Table 1.

AUTHOR



Francis Enejo Idachaba obtained his PhD in Electronics and Telecommunication Engineering from the University of Benin in Edo State Nigeria in 2009 where he developed a low cost GSM system for rural mobile telecommunication. He obtained his Master of Engineering degree in Electronics and Telecommunication (with a Distinction) from the University of Benin in Edo state in 2002 and his first degree in Electrical/ Electronics Engineering from the Federal University of Technology Yola in

Adamawa state Nigeria in 1997. His lecturing experience spans a period of over ten years, six of which were at the Federal Polytechnic Idah in Kogi state where he taught Electronics and Telecommunication. He currently teaches in the department of Electrical and Information Engineering, Covenant University Ota. His research interests include design of low cost communication infrastructure, rural telephony and development of remote monitoring and control systems.

Table 2: Heater test results

ST (°C)	PT (°C)	Status led	System state
35	25–34	Blinking	Heater on
35	35	On	Heater off
45	25–44	Blinking	Heater on
45	45	On	Heater off

ST: Set temperature; PT: Process temperature.

Table 2 shows the heater and status LED test results. These results show that when the heater is on, it stays on until the ST is attained and after that, the heating process stops.

3. CONCLUSION

The results in Table 1 and the output after calibration show a change from the diode's negative temperature coefficient to a positive temperature coefficient, which eases system calibration; the device control mechanism shows a switching of the heater in line with the control algorithm. This switches the heater off automatically when the ST is attained. The digital readout also provides a means of observing the temperature of the process as it rises up to the ST when the heater is switched off.

REFERENCES

- G C Barney. Intelligent Instrumentation. Microprocessor Application in Measurement and Control. New Delhi Prentice-hall of India;1985.
- A Pal. Microprocessor Principles and Application. New Delhi: Tata McGraw-Hill; 1990.
- L Warnes. Electronics and Electrical Engineering Principles and Practice 2nd ed. London: Macmillan Press; 1998.
- R E Veares. Microprocessor Interfacing. London: Heinemann-Newnes; 1990.
- J E Eziashi. Power Electronics and Transducers M.Eng lecture note. Nigeria: University of Benin; 2002.
- J Graeme. Application of Operational Amplifiers Burr-Brown Research Corporation. New York: McGraw Hill; 1973.
- S Franco. Design with Operational Amplifiers and Analog Integrated Circuits. New York: McGraw-Hill; 1988.

Email: idachabafe@yahoo.com

Copyright of IETE Journal of Research is the property of Medknow Publications & Media Pvt. Ltd. and its content may not be copied or emailed to multiple sites or posted to a listserv without the copyright holder's express written permission. However, users may print, download, or email articles for individual use.