

# A Probabilistic Modeling of Distribution Equipment Deterioration; An application to Transformer Insulation.

<sup>1,a</sup> A.U. Adoghe, <sup>2,b</sup> C.O.A. Awosope and <sup>3,c</sup> J.C. Ekeh

<sup>1,3</sup> Department of Electrical and Information, College of Science and Technology, Covenant University, Ota, Nigeria. <sup>a</sup>Email: [adoghe\\_tony@yahoo.com](mailto:adoghe_tony@yahoo.com) or [adoghe\\_tony@ieee.org](mailto:adoghe_tony@ieee.org), Mobile: 0803-388-5086

<sup>2</sup> Department of Electrical/Electronics, Faculty of Engineering, University of Lagos, Lagos, Nigeria

**Abstract--** In this paper, a probabilistic maintenance model relating probability of failure to maintenance activity had been developed for maintainable distribution components. This model incorporates various levels of insulation deterioration and minor maintenance state.

It was applied to a distribution transformers ranging from 300 kVA to 15 MVA in Abule-Egba Business Unit network of Power Holding Company of Nigeria. The result obtained from the application study and model simulation verified the mathematical analysis of the developed model. Although this application illustrates the development of a probabilistic deterioration model for a distribution transformer, it can be applied to predict the performance of other distribution components in the electric power system network.

**Index Term--** Maintenance Model, Insulation Deterioration model, Distribution Transformer, Model Simulation, Probabilistic approaches, Mathematical Analysis.

## 1. INTRODUCTION

Several deterministic and stochastic approaches have been developed to model component deterioration [1]. Deterministic approaches, such as straight – line extrapolation, and multiple regression, have the advantages of being simple to develop and easy to use. However, the existence of deterioration parameters that are not typically observed or measured, subjectivity and inaccuracy of component inspection, and stochastic nature of the deterioration process led to the wide spread of stochastic models. These models are able to capture the physical and inherent uncertainty, model uncertainty, and statistical uncertainty, while predicting the future performance of distribution components [2].

Although the deterioration of distribution components is a continuous and gradual process that may span over decades, discrete states are commonly used to represent facility conditions. This is because discrete states simplify facility inspection, deterioration modeling, and maintenance optimization [3].

Stochastic models used to predict the deterioration of distribution components can be grouped into two main categories: state – based models and time – based models

State – based models predict the probability that a facility will have a change in its condition state during a fixed time interval and accumulate this probability over multiple intervals. Markov chain models and semi – markov models are the most common example of state – based models.

Time – based models predict the probability distribution of the time taken by a component to change its current condition state to the next lower condition state.

In this paper, a state - based stochastic deterioration models for evaluating the performance of a distribution transformer in its deteriorating state is developed.

The transformer failure statistics in Abule-Egba distribution network is presented in section two, followed by the development of the Markov – chain model for evaluating the performance of the distribution transformer in section three. The fourth section discusses the results obtained from model simulation as it verified the mathematical analysis of the developed model and the conclusions is followed in section five.

## 2. TRANSFORMER FAILURE STATISTICS IN ABULE-EGBA

Failure of power transformers can greatly affects the power delivery. The leading cause of transformer failures is “Insulation failure”. This category of failure includes substandard or defective installation, insulation deterioration, and short circuits, but voltage surges, lightning and line faults are excluded.

Table 2.1 lists the number of failures for each cause of failure investigated. The risk involved in a transformer failure is of two types namely: The frequency of failure and the severity of the failure. A description of each cause category is given below.

Table 2.1 Number of transformer failure for each cause of failure

CAUSES OF FAILURE	NUMBER OF TRANSFORMER FAILURE
Insulation Failures	28
Design / Material / Workmanship	27
Oil Contaminations	9
Overloadings	5
Fire /Explosions	1
Line Surges	4
Improper Maintenance	6
Loose Connections	2
Lightning strikes	2
Moisture	1
Unknown	17
Total	97

**Insulation Failure:-** This failure was the leading cause of failure in the distribution network considered. This category excludes those failures where there was evidence of lightning or a line surge. The following four factors were discovered to be responsible for insulation deterioration:-

Pyrolysis (heat), Oxidation, Acidity, and Moisture. But moisture is reported separately. The average age of the transformers that failed due to insulation was 15 years.

**Design/ Manufacturing Errors** – this groups includes conditions such as ; loose or unsupported leads, loose blocking , poor brazing, inadequate core insulation, inferior short circuit strength, and foreign objects left in the tank. During the investigation, this is the second leading cause of transformer failures.

**Oil Contamination** – this refers to those cases where oil contamination can be established as the cause of failure. This includes slugging and carbon tracking.

**Overloading-** this category pertains to those cases where actual overloading could be established as the cause of the failure. It includes only those transformers that experienced a sustained load that exceeded the nameplate capacity.

**Fire / Explosion-** this category pertains to those cases where a fire or explosion outside the transformer can be established as the cause of the failure. This does not include internal failures that resulted in fire or explosion.

**Line surge:** this includes switching surges, voltage spikes, line faults/flashovers, and other abnormalities. This significant portion of transformer failures suggests that more attention should be given to surge protection, or the adequacy of coil clamping and short circuit strength.

#### **Maintenance/Operation**

Inadequate or lack of maintenance was a major cause of transformer failures in the network considered, when overloading, loose connections and moisture are included. This includes disconnected or improperly set controls, loss of coolant, accumulation of dirt and oil, unkept transformer location and corrosion. Inadequate or no maintenance has to

bear the blame for not discovering incipient troubles that could have been corrected if maintenance was carried out.

**Loose connections:** this includes workmanship and maintenance in carrying out electrical connections. One major problem is the improper mating of dissimilar metals, although this has decreased recently. Loose connections could be included in the maintenance category.

**Lightning:** failure due to lightning is now fewer in number than previous studies carried out in this areas. Unless there is confirmation of a lightning strike, a surge type failure is categorized as “line surge”.

**Moisture:** The moisture category includes failures caused by leaky pipes, leaking roofs, water entering the tanks through leaking bushings or fittings, and confirmed presence of moisture in the insulating oil. This could be included in the inadequate maintenance category.

#### **Transformer Ageing**

In table 2.1, we did not add “age” as a cause of failure. Ageing of insulation system reduces both the mechanical and dielectric-withstand strength of the transformer. As the transformer ages, it is subjected to faults that result in high radial and compressive forces. As the load increases, with system growth, the operating stresses increase. In an ageing transformer failure, typically the conductor insulation is weakened to the point where it can no longer sustain mechanical stresses of a fault. Turn to turn insulation then suffers a dielectric failure, or a fault causes a loosening of winding clamping pressure, which reduces the transformer’s ability to withstand future short circuit forces.

Table 2.2 displays the distribution of transformer failure by age

The age of transformers deserves special attention, because the world went through significant industrial growth in the post world war II era, causing a large growth in base

infrastructure industries, especially the electric utilities. [4]. World energy consumption grew from 1 trillion to 11 trillion KWhr, in the decades following the war [5]. Most of this equipment is now in the ageing part of its life cycle.

TABLE 2.2

LISTS OF THE DISTRIBUTION OF TRANSFORMER FAILURE BY AGE.

Age at Failure	No of Failures
0 to 6 years	8
7 to 11 years	6
12 to 16 years	12
17 to 21 years	12
Over 21 years	24
Unknown	35

3.0 TRANSFORMER MAINTENANCE MODEL

A general probabilistic model of the impact of maintenance on reliability proposed in this work is applied on transformer as shows below. The model represents the deterioration process in a distribution transformer using discrete stages. In figure 3.1, deterioration process of a transformer is approximated by three discrete stages:  $D_1$ ,  $D_2$ , and  $D_3$ . At each state, oil is inspected to determine its condition. After the inspection, oil condition is determined by some defined criteria as indicated in [4].

The criteria categorize oil condition into three groups as follows:

Condition  $C_1$  means - Satisfactory

Condition  $C_2$  means – Should be reconditioned for further use.

Condition  $C_3$  means – Poor condition, dispose off and replace.

Maintenance action is assigned corresponding to the oil condition. If oil condition is  $C_1$ , nothing is done. If oil condition is  $C_2$  or  $C_3$ , two options are available and are assigned with different probabilities: oil filtering or oil replacement.

If for example, the present stage is  $D_2$  with oil condition  $C_2$ , the probability of oil filtering will be higher than oil replacement. On the other hand, if the present state is  $D_2$  with oil condition  $C_3$ , the probability of oil replacement will be higher. After maintenance, the device will have three options, going to state  $D_1$ ,  $D_2$  or  $D_3$ . The probability of transferring to other states depends on the present state and the maintenance strategy adopted.

Further, the maintenance process is divided into three levels namely: Do nothing, Basic Maintenance and Replacement.

Once the suggested maintenance action is taken, the subsequent condition of the transformer is determined.

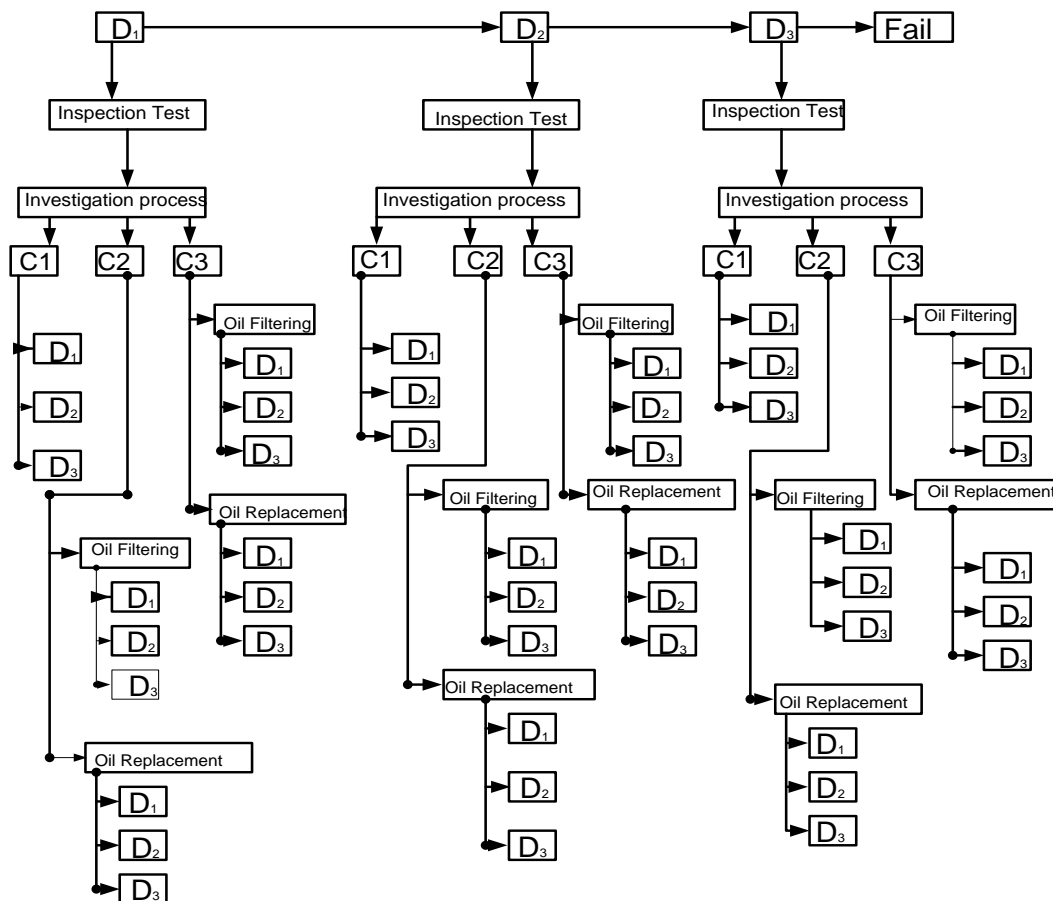

Figure 3.1 Transformer Maintenance Model

The model takes data from various inspection and maintenance tasks and the frequency of performing the tasks as inputs and gives the failure rates as output. The changes in the “mean time to failure” indicator can be observed by considering different inspection and maintenance actions. This model can help asset managers to evaluate the performance of distribution transformer in obtaining optimum maintenance intervals such that both the transformer availability and the life span are balanced.

Various inspection tests and maintenance actions considered in the model are shown in table 3.1 and table 3.2 respectively. The rating of the transformers range from 300 – 1000kVA and their high voltage rating ranges from 13.8 – 34.5kV. The units were manufactured between 1985 and 1995 by different transformers’ manufacturers and the oil used in all units was mineral oil provided from different suppliers. The unit was taken from Abule-Egba distribution network to conduct routine maintenance to evaluate their working conditions.

TABLE 3.1  
TRANSFORMER MAINTENANCE TASKS

Transformer Activity task	Standard Checklist to ensure transformer availability.
Main Components.	Winding, Cooling agent (for example, oil, gas, or air), Bushing, Tap Changer.
Operating Mechanism.	Transforms voltage from one level to another, preserving the same voltage frequency.
Deterioration process	Insulation paper in the winding, oxidation of oil.
Particles produced by aging process	Sludge, water, fiber, Gases (CO, CO2 etc), Furfural, partial Discharge.
Failure mode	<ul style="list-style-type: none"> <li>- Thermal related faults</li> <li>- Dielectric related faults</li> <li>- General degradation related faults</li> <li>- Mechanical related faults</li> </ul>
Inspection tests	<ul style="list-style-type: none"> <li>- Dielectric strength, resistivity, acidity, moisture content</li> <li>- Routine oil sampling test,</li> <li>- Dissolved gas analysis</li> <li>- Furfural analysis</li> <li>- Partial discharge monitoring.</li> </ul>
Maintenance	<p><b>For oil Immersed transformer</b></p> <ul style="list-style-type: none"> <li>- Oil filtering (online/offline</li> <li>- Oil replacement.</li> </ul>

✚ Stated limits for Service- Aged oils for Transformers [6].

TABLE 3.2  
RATED LIMIT FOR VALUES OF TRANSFORMER OIL FOR VOLTAGE CLASS [7].

Test	BS / ASTM Standard	Accepted value for aged oil
Dielectric breakdown (kV)(Min.)	D – 877	26
Interfacial tension, (Mn/m or dynes/cm)(Min.)	D – 971	24
Water Content, (ppm)(Max.)	D – 1583	35
Total Acidity (Mg KOH/g oil)(Max)	D – 644	0.3

**3.1 Model parameters**

Table 3.3 shows the list and definition of the parameters that are used in transformer maintenance model.

Notice that model parameters 1 and 3 can be approximated from historical data of oil condition of a physical transformer. These parameters are given, whereas, parameter 2, which is the inspection rate of each stage can be varied to achieve high reliability with minimum cost. Therefore, this parameter is of paramount importance in determining the impact of maintenance on transformer analysis.

The analysis covers two aspects:

- Mean time to the first failure, and
- All associated costs (failure, maintenance and inspection costs respectively).

The simulation results from matlab for this model will be presented under results and discussion.

TABLE 3.3  
LIST OF MODEL PARAMETERS AND DEFINITIONS

Model Parameters	Definitions
(1) Mean time in each stage	It is defined as mean time the device spends in each stage. The inverse of the mean time is the transition rate of the corresponding stage in deterioration process.
(2) Inspection rate of each stage	It is defined as the rate at which the inspection is done. The inspection may be followed by maintenance.
(3) Probabilities of transition from one state to others.	<p>These parameters are the probabilities of transition from one state to others. These probabilities includes</p> <ul style="list-style-type: none"> <li>• The oil condition after inspection</li> <li>• The probabilities of transferring from any oil condition to a given stage.</li> <li>• The probabilities of filtering or replacing the oil and</li> <li>• Probabilities of transferring to each stage after maintenance.</li> </ul>

### 3.2 Equivalent Mathematical models for transformer maintenance.

Two equivalent models are used to simplify the transformer maintenance model shown in figure 3.1. The equivalent models have three discrete stages representing the deterioration processes. We assume that decision is taken at the end of every inspection. Decision for maintenance and inspection rate of each stage is considered to be an equivalent repair rate.

Let  $y_1$  = mean time in state 1(year),

$y_2$  = mean time in state 2(year)

$y_3$  = mean time in state 3(year)

$\mu_{21}$  = Repair rate from state 2 to 1(/year),

$\mu_{32}$  = Repair rate from state 3 to 2 (/year),

$\mu_{31}$  = Repair rate from state 3 to 1 (/year).

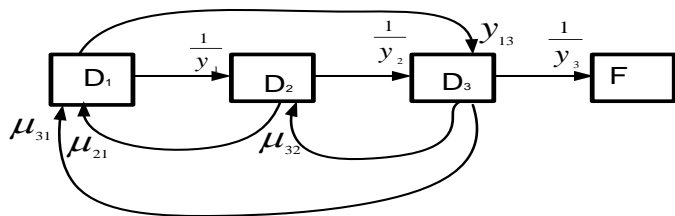

(a) Maintenance Model

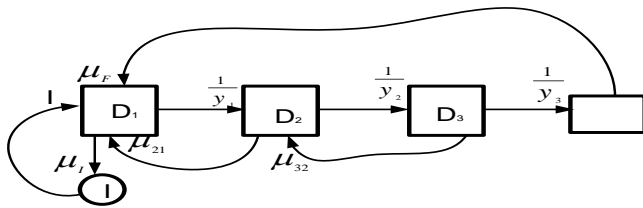

(b) Inspection Model

Fig. 3.2. Equivalent Maintenance Model

Various inspection tests are considered in developing the model. In particular, the following tests were considered in this model. Oil filled transformer are considered in this study. The underlisted items form the basis for the inspection tasks in this model.

- Dielectric strength verification,
- Resistivity, acidity and moisture content analysis,
- Routine oil sampling test,
- Dissolved gas analysis, and
- Furfural analysis

The condition of the transformer can be obtained by comparing the measured values with the working standard. In the case of the transformer oil, table 3.2 could be regarded as the working standard.

### 4.0 RESULTS AND DISCUSSIONS

The simulation result of the relationship of each inspection rate for the transmission model and MTTF are shown in figure 4a-c and 4.1a-c. The observations that could be drawn from these simulation results are as stated below:

1. In figure 4a, the MTTF is seen to decrease with  $i_1$ . This is associated with the assumption of exponential distribution of time spent in each stage. The assumption of exponential distribution implies constant failure rate. This becomes very important in stage  $D_1$ . This implies that the inspections, which will result in going back to  $D_1$ , will not improve the time to failure in  $D_1$ . However, those that will lead to  $D_2$  and  $D_3$  will result in deterioration. This means that, if we assume an exponential distribution for stage 1, maintenance at this stage will not be necessary.
2. In figure 4b, it was observed that MTTF increases at a decreasing rate with  $i_2$  and then remains constant afterwards.
3. In figure 4c, MTTF and  $i_3$  were observed to possess positive linear relationship.

The next stage of simulation is to modify the model in figure 3.1 by representing state 1 by three sub-unit in order to nullify the assumption of exponential distribution. Although each sub-unit is exponentially distributed, the overall  $D_1$  is not and hence will experience deterioration. The simulation results of the relationship of each inspection rate and MTTF based on this arrangement is shown in figure 4.1a – 4.1c.

In figure 4.1a, MTTF is observed to increase rapidly when  $i_1$  is correspondingly increased and then decreases slightly at high  $i_1$ . The simulation results as shown in figure 4.1b and 4.1c gave the same observation as that obtained in figure 4b and 4c.

The simulation results suggest that inspection rate of  $D_1$  could help in prolonging MTTF. In addition, carrying out inspection of  $D_2$  beyond a certain value will have a little or no impact on reliability. Figure 4.1c however, indicates that transformer life-time will be longer with an improved inspection rate at stage  $D_3$ .

#### 4.1 Simulation Result Analysis and discussion

**Inspection rate of stage1:** It is possible that inspection and maintenance will reduce MTTF at very high inspection rate of stage1 (high inspection in stage1 will increase  $\lambda_{13}$ , thus, denominator may be large). This will increase the failure rate from stage1 to 3, therefore, MTTF may decrease. This suggestion is verified by the simulation result in figure 4.1a.

**Inspection rate of stage 2:** High inspection rate of stage 2 will increase the repair rate from stage 2 to 1 ( $\mu_{21}$ ). Let assume that this repair rate is very high,

$$MTTFF = \frac{1 + \gamma_3(\mu_{31} + \mu_{32} + \lambda_{13})}{\lambda_{13}}$$

This shows that MTTFF will increase to a constant value. This also is verified by the simulation result in figure 4.1a

**Inspection rate of stage 3:** High inspection rate of  $D_3$  will increase the repair rate from stage 3 to 2 ( $\mu_{32}$ ) and also repair rate of stage 3 to 1 ( $\mu_{31}$ ). These rates are linearly related to MTTFF; therefore, the lifetime will increase linearly with inspection rate of stage 3. This again is verified by the simulation result in figure 4.1c.

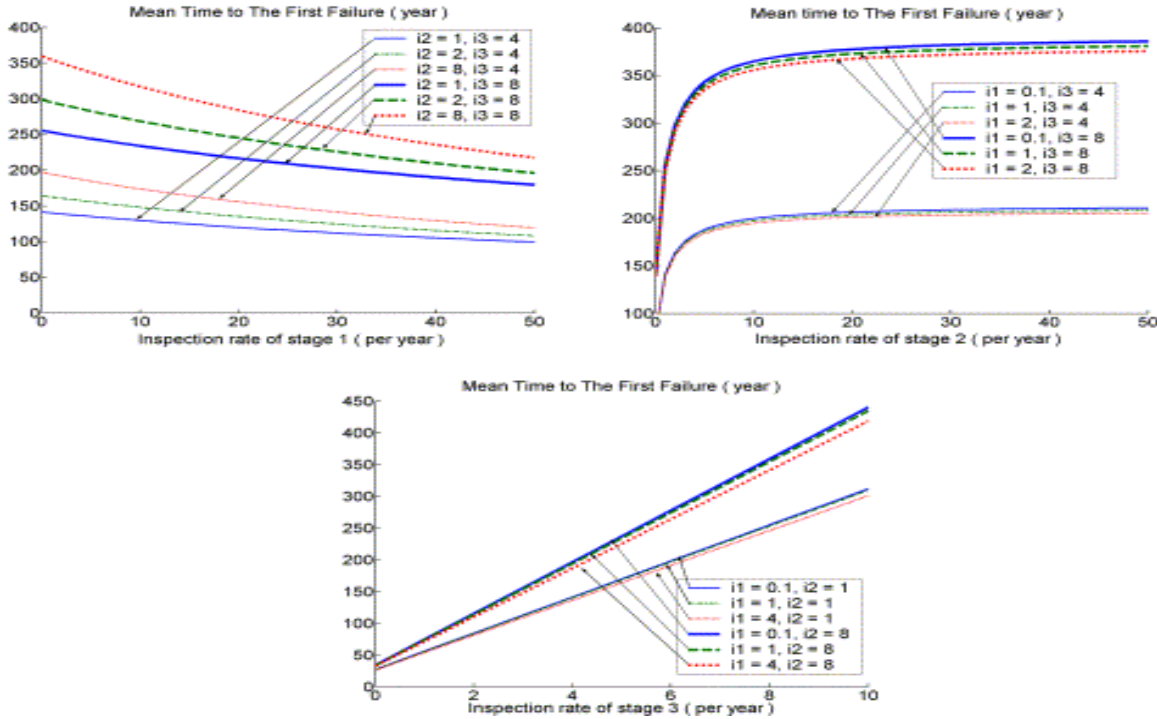

Fig. 4a. – 4c the relationship between inspection rate and MTTFF

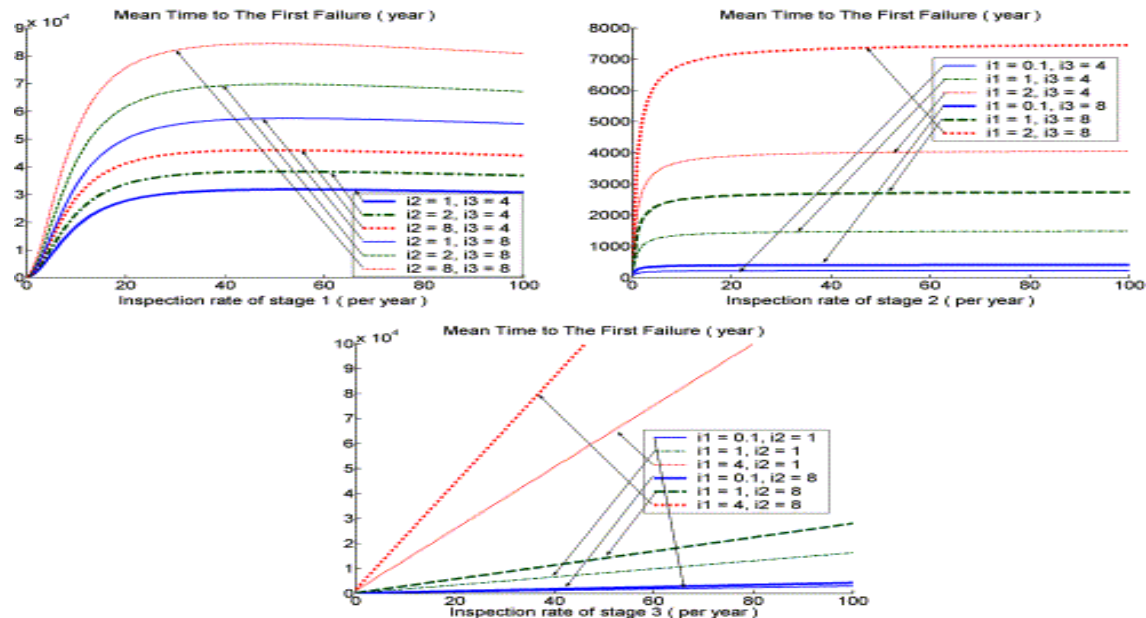

Fig. 4.1a -4.1c The relationship between inspection rate and MTTFF when stage 1 is represented by three sub-units.

## 5.0 CONCLUSIONS

A probabilistic maintenance model that link maintenance and reliability for describing the impact on reliability of gradually deteriorating equipment with periodic inspections that can lead to various possible maintenance strategies has been developed.

Simulation results from MatLab are shown and verified by mathematical equations of the equivalent model. The analysis of the simulation results suggests that inspection is only introduced to determine the stage of the device deterioration.

This model was applied to a distribution transformer located in Abule-Egba business unit network considered in this paper.

The main strength of this model is that it allows one to assess the state of insulation of several different groups of transformers relative to each other. It is a fact of life that prediction (forecast) of the condition of a distribution transformer stand on a firmer ground if they are relative rather than absolute.

## REFERENCES

- [1] Brown, R.E., Frimpong, G. & Willis, H.L. "Failure Rate Modeling Using Equipment Inspection Data", IEEE Transactions on power systems. Vol. 19, No. 2, May 2004.
- [2] Satish N, Panida J, Mladen K, and Chanan S., "Circuit Breaker and Transformer Inspection and Maintenance: Probabilistic Models" 8<sup>th</sup> International Conference on Probabilistic Methods Applied to power systems, Iowa State University, Ames, Iowa, September 12-16, 2004.
- [3] Jirutitijaroen, P, Singh, C., "Oil-immersed transformer inspection and maintenance: probabilistic models" in proceedings of the 2003 North American power Symposium conference, pp 204-208.
- [4] Ward, B. H., "A Survey of New Techniques in Insulation monitoring of power Transformers", IEEE Electrical Insulation Magazine, Vol17, No3, pp. 16-23, 2001.
- [5] Ward S.A., "Evaluating transformer condition using DGA Oil analysis", IEEE CEIDP, pp. 463-468, 2003.
- [6] NYNAS, "Transformer oil handbook, June, 2004.