

Electronic Simulation and Hardware Implementation of Two Coupled Periodically Forced ϕ^6 -Duffing and ϕ^6 -Van der Pol oscillators and its Application to Secure Communication

Adelakun Adedayo^{1,2} Njah Abdulahi³ Olusola Olasunkanmi³ Wara Samuel⁴

1.Department of Physics, Federal University of Agriculture Abeokuta, Ogun state, Nigeria.

2.Department of Physics, Federal University of Technology, Akure, Ondo state, Nigeria

3.Department of Physics, University of Lagos, Akoka, Lagos state, Nigeria

4.Department of Electrical Electronic, Covenant University, Ota, Ogun state, Nigeria

Abstract

Confirmation of the existence of complex behavior and synchronization of non-identical chaotic systems as reported in literature attracts much interest in secure communication, but practical implementation is still challenging. In this work, the dynamics of coupled non-identical circuits comprising periodically forced ϕ^6 -Duffing and ϕ^6 -Van der Pol oscillators is investigated via electronic simulation using Multism software and hardware implementation on electronic circuits board. After complete synchronization is achieved between the ϕ^6 -Duffing (Transmitter) and ϕ^6 -Van der Pol (receiver) circuits through the variation of the coupling resistor of the controller, its application to secure communication is therefore demonstrated experimentally and via multism. The results from the electronic simulation and hardware implementation on bread board using analog components are in good agreement with the numerical results in literature.

Keywords: Electronic simulation, Periodically Forced ϕ^6 -Duffing oscillator, Periodically Forced ϕ^6 -Van der Pol oscillator, Secure Communication, Synchronization.

1. Introduction

Chaos synchronization is a phenomenon that may occur when two or more chaotic systems are coupled. The coupling of dynamical systems takes two basic forms: Unidirectional (master-slave) coupling in which two systems are coupled in such a way that the slave system tracks or mimics the motion of the master system [1-2] or bidirectional (mutual) coupling in which the two systems influence each other's dynamics until their dynamics become identical thereby achieving synchronization [3]. This is the case of synchronization of networks of systems [4], often happening naturally, for instance, in certain biological systems. Complete synchronization of two systems was first achieved by Pecora and Carrol in 1990 using replacement method. Thereafter, many researchers have carried out series of chaos control and synchronization from different disciplines, establishing other types of synchronization including generalized, anticipated, sequential, phase, measure, lag and projective synchronizations [5-6]. In literature, various numerical schemes have been applied for chaos control synchronization such as OGY method [7], active control method [8], adaptive control method [9], time-delay feedback method [10], backstepping design method [11], sampled-data feedback synchronization method [12], etc. Also, synchronization of chaotic systems has been explored very intensively by many researchers using electronic circuits, such as Rössler circuit [13], Duffing circuit [14], Chua circuit [15], Double Bell circuit [16] e.t.c.

Master-Slave synchronization has many applications in physical systems such as chemical reactor [17-18], biomedical systems [19-20], solar activity [21-22], cryptography [23], and secured communication [24-26]. In secure communication, the master-and slave system serves as the transmitter and receiver respectively, in which the message is recovered at the receiver from the channel when the transmitter and receiver systems are

synchronized [27-28]. In the past, synchronization of ϕ^4 and ϕ^6 chaotic oscillators via numerical simulation have been carried out and applied to secure communication. The results of these simulations showed that the

dynamic of ϕ^6 oscillators is more complex than their corresponding ϕ^4 oscillators and hence offer more security of masked information during transmission [29-30]. In this work, we carry out computer simulation and practical implementation of coupled non-identical chaotic systems, comprising periodically forced

ϕ^6 -Duffing and ϕ^6 -Van der Pol oscillators using analog components to achieve synchronization and finally applied it to secure communication. The electronic simulations via multism and experimental implementation

results obtained are comparable with numerical simulation results reported in literature. To the best of our knowledge, computer simulation via electronic softwares such as Multisim and experimental implementation using hardware on bread board of ϕ^6 chaotic oscillators have not been investigated.

Finally, the effectiveness of the coupling between the two non-identical circuits and its application in secure communication system is presented in details. The rest of the paper is organized as follows. Section 2 describes the numerical simulation using fortran code and electronic simulation using Multisim for both ϕ^6 -Duffing oscillator and ϕ^6 -Van der Pol oscillator. Section 3 deals with the circuit design, electronic simulation via multisim and hardware implementation of coupled ϕ^6 -Duffing and ϕ^6 -Van der Pol circuits while, section 4 deals with the application of the synchronization results of both the electronic simulation and hardware implementation of the coupled ϕ^6 - oscillators in information masking in secure communications. Finally, section 5 concludes the paper.

2. Numerical Simulation

2.1 Periodically Forced ϕ^6 -Duffing and ϕ^6 -Van der Pol Circuits

The periodically forced ϕ^6 -Duffing oscillator (1) and ϕ^6 -Van der Pol oscillator (2) are second order non-autonomous systems with nonlinear terms $\beta x^3 + \delta x^5$ and $\mu x^2 \dot{x} + \beta x^3 + \delta x^5$ respectively, which exhibit chaos.

$$\ddot{x} + \lambda \dot{x} + \alpha x + \beta x^3 + \delta x^5 = f_1 \cos w_1 t \quad (1)$$

$$\ddot{x} + \mu(1 - x^2)\dot{x} + \alpha x + \beta x^3 + \delta x^5 = f_2 \cos w_2 t \quad (2)$$

where $\mu, \lambda, \alpha, \beta, \delta$ are constant parameters, while f_1, f_2 and w_1, w_2 are amplitudes and angular frequencies of the forcing respectively. The attractors for system (1) and (2) are given in Fig. (1) and (2) respectively for the parameter values specified therein.

2.2 Multisim Simulation and Experimental Implementation of ϕ^6 Duffing and ϕ^6 -Van der Pol Circuits

The ϕ^6 -Duffing and ϕ^6 -Van der Pol circuits each contains a variable resistor R_7 , which serves as a control parameter used in varying the value of δ to enable the systems exhibit chaotic dynamics. The relation between the variable resistors and δ is

$$\delta = \frac{R_8}{R_7} \quad \text{for } \phi^6 \text{ - Duffing oscillator} \quad (3)$$

$$\delta = \frac{R_9}{R_7} \quad \text{for } \phi^6 \text{ -Van der Pol oscillator} \quad (4)$$

The circuit is implemented with operational amplifiers ($UA471CD$), multipliers ($AD633AN$) as analog components, resistors ($R_1 - R_9$), capacitors ($C_1 - C_2$) as additional and subtraction components with the power source of $15V$. Figs. 2(a-b) show the analog circuits for ϕ^6 -Duffing and ϕ^6 -Van der Pol oscillators and their corresponding phase portrait of the attractors are displayed in Figs. 3 (a-b) for the electronic software simulation using multisim and Figs. 4 (a-b) for the experimental implementation on electronic breadboard respectively.

3. Unidirectional Coupling of the Non-Identical and Periodically Forced ϕ^6 -Duffing and ϕ^6 -Van der Pol Circuits.

In this section, we couple the drive (master) and response (slave) systems unidirectionally such that the master system influences the dynamics of the slave system until synchrony takes place. We used multipliers (AD 633AN) and operational amplifiers (UA 741 CD) for the simulation / implementation. The computer simulation of the unidirectional coupling is shown in Fig. 5, with a coupling strength $R_c = R_{1s}$ of the two non-identical systems. In Fig. 6 (c), synchronization occur at $R_c \leq 1m\Omega$, while it does not occur when $R_c > 1m\Omega$ as shown in Fig. 6 (a) and (b) for $R_c = 1\Omega$ and $10m\Omega$ respectively. The physical implementation of the coupled circuits and the result showing complete synchronization is displaying in Fig. 7.

4. Application to Secure Communication Network

In power electronics especially in chaos-based secure communication network, synchronization is the critical issue due to the necessity for both transmitter (drive) and receiver (response) to be synchronized. The sinusoidal information signal $i(t)$ of amplitude 1V and frequency 20KHz is added to the generated chaotic signal $x(t)$ from the transmitter (drive system) to give the chaotic masking transmitted signal $s(t) = x(t) + i(t)$ which is fed into the receiver. Figs. 8 (a) and (b) show the electronic simulation via multism and physical realization of the coupled periodically forced ϕ^6 -Duffing and ϕ^6 -Van der Pol circuits with receiver, while Figs. 9 (a) and (b) show the simulation results.

5. Conclusion

In this paper, the dynamics of coupled non-identical and periodically forced ϕ^6 -Duffing and ϕ^6 -Van der Pol circuits have been investigated via electronic simulation and hardware implementation on electronic board.

Complete synchronization was achieved for coupling strength $R_c \leq 1m\Omega$. With the drive ϕ^6 -Duffing oscillator as the transmitter and the response ϕ^6 -Van der Pol oscillator as the receiver, the synchronized systems was applied in information masking in secure communication. Chaos synchronization and chaos masking were realized using electronic software (Multism) and experimental implementation on electronic circuits board. The results showed that the chaotic masking transmitted signal for a sinusoidal information signal of 1V and frequency 20KHz was masked and retrieved successfully, thereby confirming the numerical results in literature.

References

- [1] Sivaperumal S., Sundarapandian V., "Hybrid Synchronization of Hyper- chaotic Qi Systems via Sliding Mode Control", Proceedings of International Conference on Systems, Control and Informatics (2013) 345-349.
- [2] Han Q. L., "On Designing time-varying Delay Feedback Controllers for Master-Slave Synchronization of Lur'e Systems", IEEE Trans. Circuits Syst. I, Reg. Papers 54 (7) (2007) 1573-1583.
- [3] Wembe E. T., Yamapi R., "Chaos Synchronization of Resistively Coupled Duffing systems: Numerical and Experimental investigation", Communications in Nonlinear Science in Numerical Simulation 14 (2009) 1439-1453 DOI: 10.1016/j.cnsns.2008.01.019.
- [4] Wu W., Zhou W., & Chen T., "Cluster Synchronization of Linearly Coupled Complex Networks under Pinning Control", IEEE Trans. Circuits Syst. I, Reg. Papers 56 (4) (2009) 829-839.
- [5] Njah A. N., "Tracking control and synchronization of the new hyperchaotic Liu system via backstepping techniques", Nonlinear Dyn. 61 (2010) 1-9, DOI: 10.1007/s11071-009-9626-5.
- [6] Yang J., Li C., "Generalized projective synchronization of unified chaotic system", Chaos Solitons and Fractals 26 (2005) 1119-1124.
- [7] Pecora L.M., Carroll T. L., "Synchronization in Chaotic Systems", Physical Review Letters 64 (1990) 821-824.
- [8] Ho M. C., Hung Y. C., "Synchronization of two different Chaotic Systems using Generalized Active Network", Physics Letters 301 (2002) 424-428.
- [9] Sundarapandian V., "Adaptive Control and Synchronization of a Highly Chaotic Attractor", International Journal of Information Systems and Techniques 1(2) (2011) 1-11.
- [10] Sundarapandian V., "Adaptive -Control and Synchronization of Uncertain Liu-Chen-Liu System",

International Journal of Computer Information Systems 3 (2) (2011) 1-6.

- [11] Park J. H., "Synchronization of Genesio Chaptic System via Backstepping Approach", Chaos, Solitons and Fractals 27 (2006)1369-1375.
- [12] Vincent U. E., "Controlling Directed Transport in Inertia Ratchets using Adaptive Backstepping Control", Act Physica Polonica B 38 (2007)1001-1011.
- [13] Sambas A., Sanjaya M. & Halimatussadiyah W. S., "Numerical simulation unidirectional chaotic synchronization of Rossler circuit and its application for secure communication", The Sci.Tech, Journal of Science and Technology 1 (2) (2012) 52-61.
- [14] Volos C. K., Kyprianidis I. M. & Stouboulos I. N., "Synchronization of two Mutually Coupled Duffing – type Circuits", International Journal of Circuits, Systems and Signal Processing 1 (3) (2007) 274-281.
- [15] Mamat M., Sanjaya M.W.S & Maulana D. S., "Numerical Simulation Chaotic Synchronization of Chua Circuit and Its Application for Secure Communication", Applied Mathematical Sciences 7 (1) (2013) 1 – 10.
- [16] Sanjaya M., Halimatussadiyah W. S., & Maulana D. S., "Bidirectional Chaotic Synchronization of Non-Autonomous Circuit and its Application for Secure Communication", World Academy of Science, Engineering and Technology 80 (2011)1067-1072.
- [17] Nastaran V., Farhad K., "Chaos Synchronization of Chemical Models", International Journal of Applied Science and Technology 1 (5) (2011) 233-243 .
- [18] Kurkina E. S., Kuretuva E. D., "Numerical analysis of the synchronization of coupled chemical reactors", Comp Math Modeling 15(1) (2004) 38-51.
- [19] Shulgin B., Girhepunje V. G., "Design and Implementation of Real Time Wireless Biomedical System Based on ZigBee-GSM interactive module", International Journal of Engineering Research and Applications (IJERA) ISSN: 2248-9622, 2(5) (2012) 1894-1899.
- [20] Neiman A., Schimansky-Geier L., Moss F., Shulgin B. & Collins J. J., "Synchronization of noisy systems by stochastic signals", Physical Rev.E 60 (1) (1999) 284-292.
- [21] Scafetta N., "The complex planetary synchronization structure of the solar system", Pattern Recogn. Phys. 2 (2014) 1–19.
- [22] Haider A., Syed Wajid A. S., Usman K., Baseer M. & Najam us Saqib, " A Synchronized Wind-Solar Hybrid System for Future Smart Grids", World Applied Sciences ISSN 1818-4952, 32 (8)(2014) 1540-1550.
- [23] Li P., Yi Z., "Compound Attack on Synchronization Based Neural Cryptography", Advances in Cognitive Neurodynamics ICCN 2007 (2008) 1019-1023.
- [24] Amalia N. M., Ioannis P. A., Stavros G. S. & Antonios N. A., " Secure communication by chaotic synchronization: Robustness under noisy conditions", Nonlinear Analysis: Real World Applications 8 (2007) 1003 – 1012.
- [25] Li Z., Li K., Wen C. & Soh Y. C., " A new chaotic secure communication system", Communication, IEEE Transactions ISSN: 0090-6778, 51 (8) (2003)1306-1312.
- [26] Branislav J., "Synchronization Techniques for Chaotic Communication Systems", Signal and Communication Technology, Springer, ISSN: 1860-4862, (2011) doi: 10.1007/978-3-642-21849-1.
- [27] Mamat M., Salleh Z., Mada Sanjaya W. S., Mohamed Noor N. M. & Ahmad, M. F. "Numerical Simulation of Unidirectional Chaotic Synchronization of Non-Autonomous Circuit and its Application for Secure communication", Adv. Studies Theor. Phys. 6(10)(2012) 497-509.
- [28] Sambas A., Sanjaya M., Mamat M., & Halimatussaiyah W.S, "Design and Analysis Bidirectional Chaotic Synchron- ization of Rossler Circuit and Its Application for Secure Communication, "Applied Mathematical Sciences 7 (1) (2013) 11-21.
- [29] Njah A. N., " Synchronization via active control of identical and non-identical ϕ^6 chaotic oscillators with external excitation", Journal of Sound and Vibration 327 (2009) 322-332.
- [30] Njah A. N., Ojo K. S., "Synch- ronization via backstepping nonlinear control of externally ϕ^6 Van der Pol and ϕ^6 Duffing oscillators", Far East Jour. of Dynamical Sys. 11 (2) (2009) 143-159.

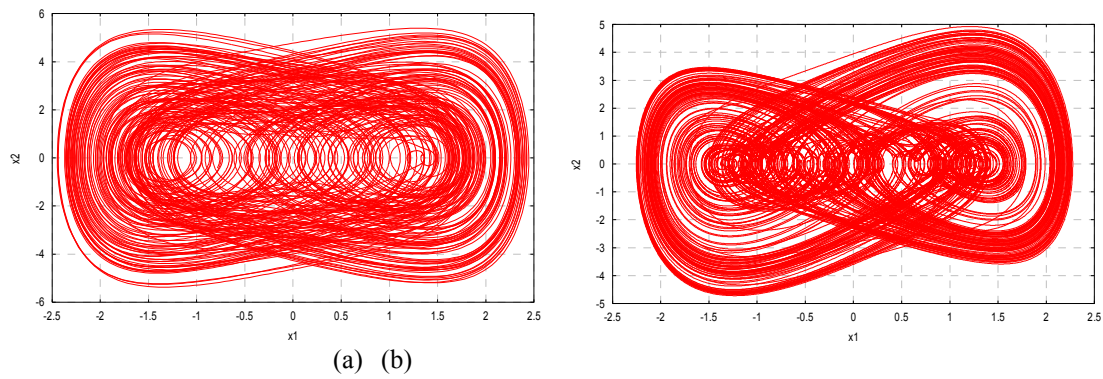
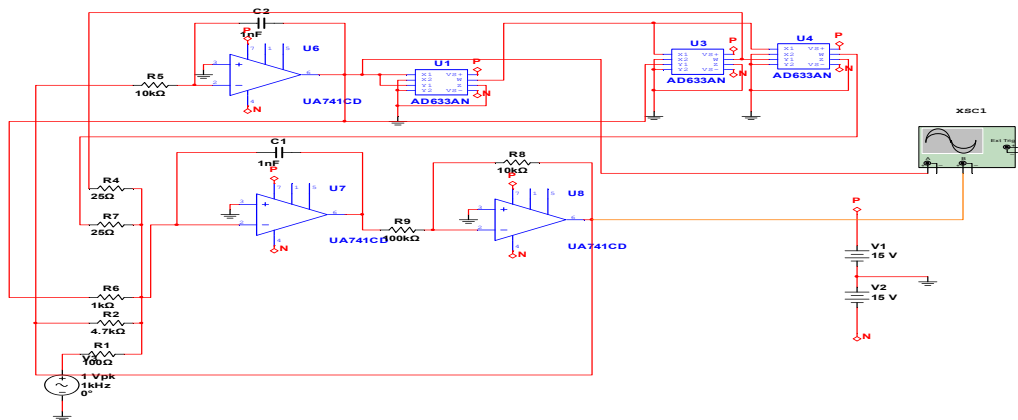
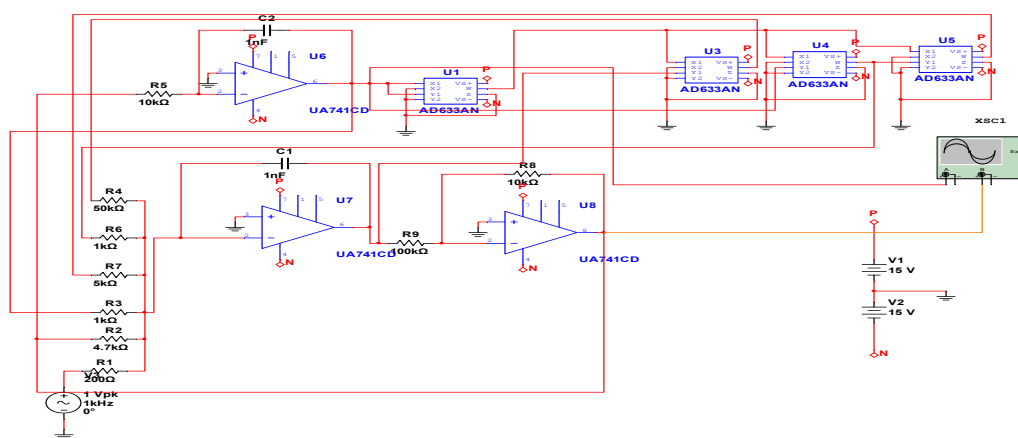

Fig.1: Phase portraits x_2 against x_1 of the chaotic attractor for (a) ϕ^6 -Duffing system with parameter values: $\mu = 0.1, \alpha = 0.46, \omega = 0.86, \beta = 1.0, \delta = 0.1, f_1 = 4.5$ for the double-well potential and, (b) ϕ^6 -Van der Pol system with parameter values: $\mu = 0.4, \alpha = 0.46, \omega = 0.86, f = 4.5, \beta = 1.0, \delta = 0.1$, for the double-well potential.



(a)



(b)

Fig.2: Analog circuit of (a) ϕ^6 -Duffing oscillator, and (b) ϕ^6 -van der Pol oscillator.

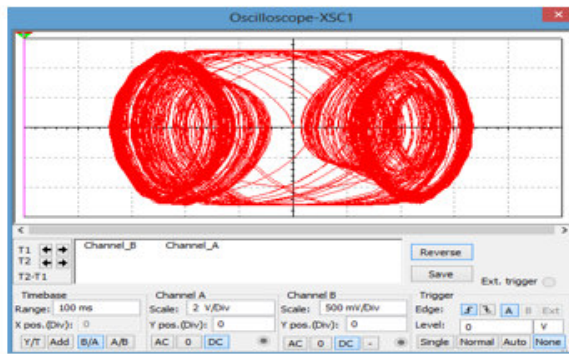

(a)

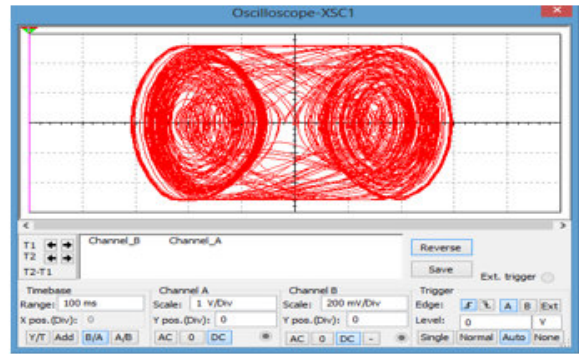

(b)

Fig.3: Double-well Phase portrait (x_2 vs x_1) of attractors from MultiSIM for (a) ϕ^6 – Duffing oscillator with $R_7 = 50\Omega$, $R_8 = 200K\Omega$ and (b) ϕ^6 – Van der Pol oscillator with $R_7 = 50\Omega$, $R_9 = 200k\Omega$



(a)

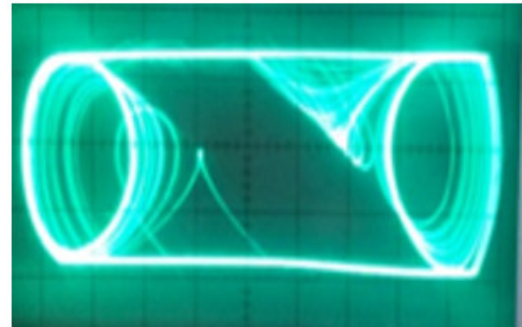

(b)

Fig.4: Double-well Attractors (x_2 vs x_1) for the Experimental implementation of (a) ϕ^6 – Duffing oscillator with $R_7 = 50\Omega$, $R_8 = 200K\Omega$, and (b) ϕ^6 – Van der Pol oscillator with $R_7 = 5k\Omega$, $R_9 = 100K\Omega$

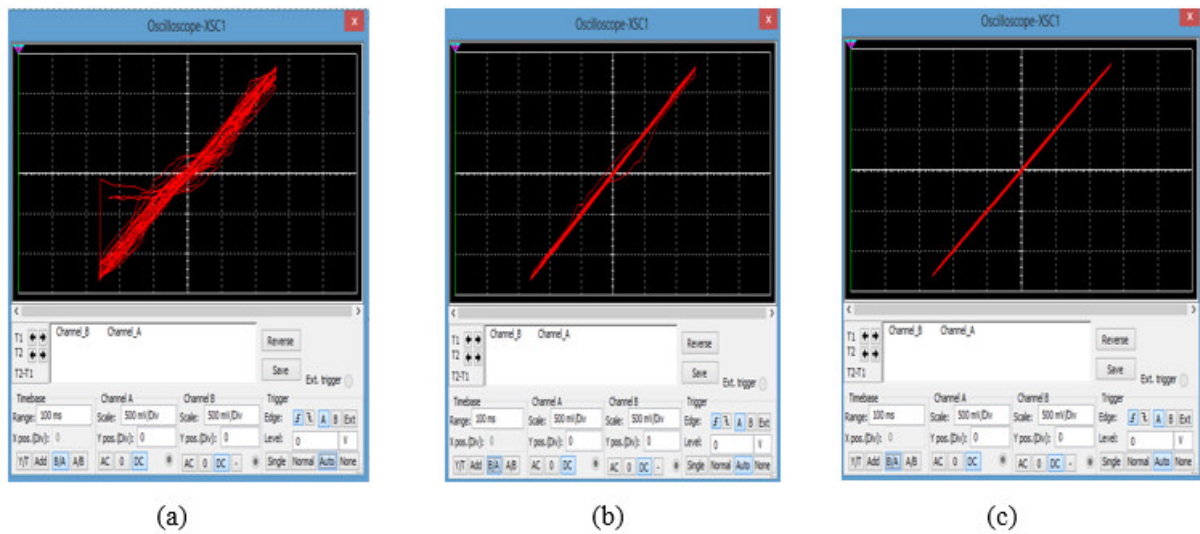

Fig. 6: Synchronization Phase portrait of x_2 vs x_1 , for (a) Incomplete synchronization at $R_C = 1\Omega$, (b) near complete synchronization at $R_C = 10m\Omega$ and (c) Complete synchronization occur when $R_C \leq 1m\Omega$ with Multisim 12.0.

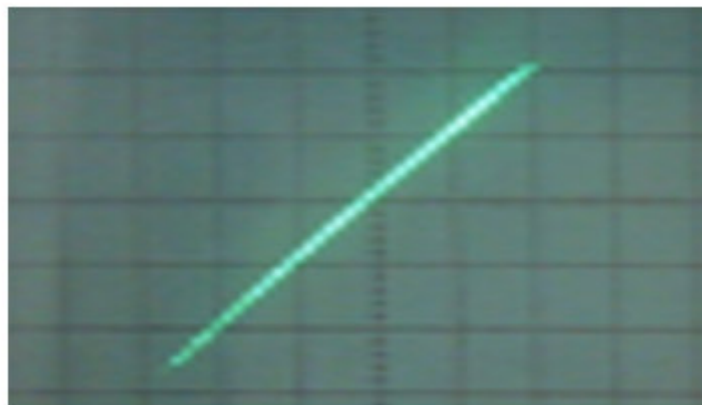
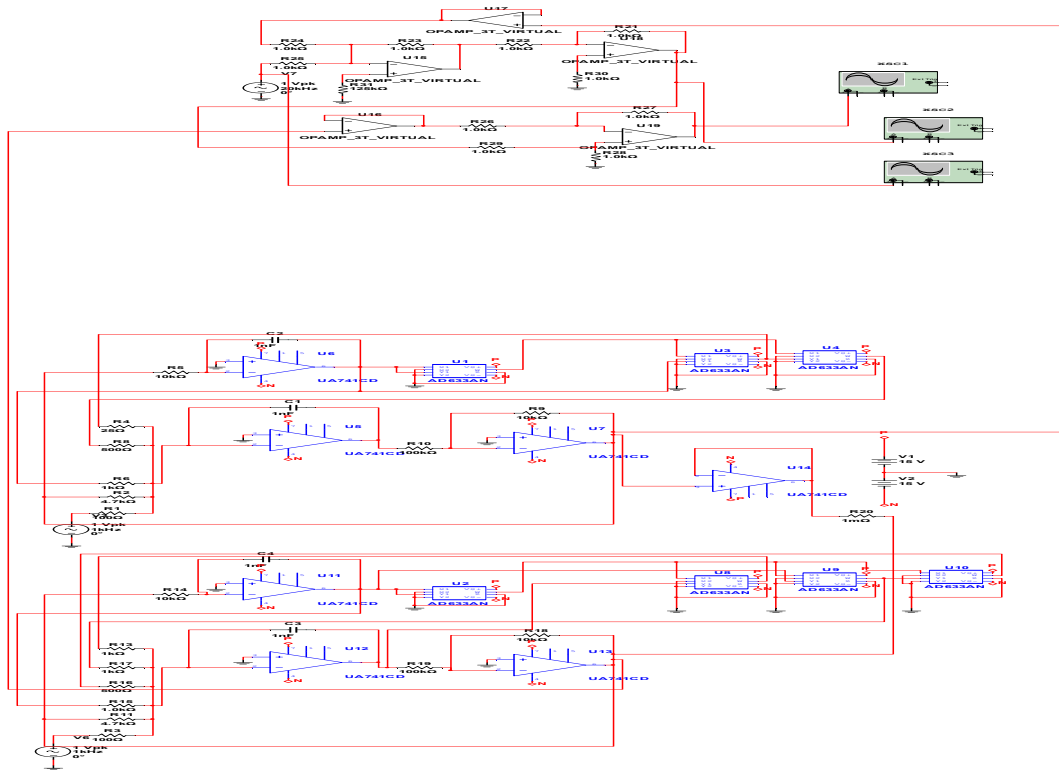
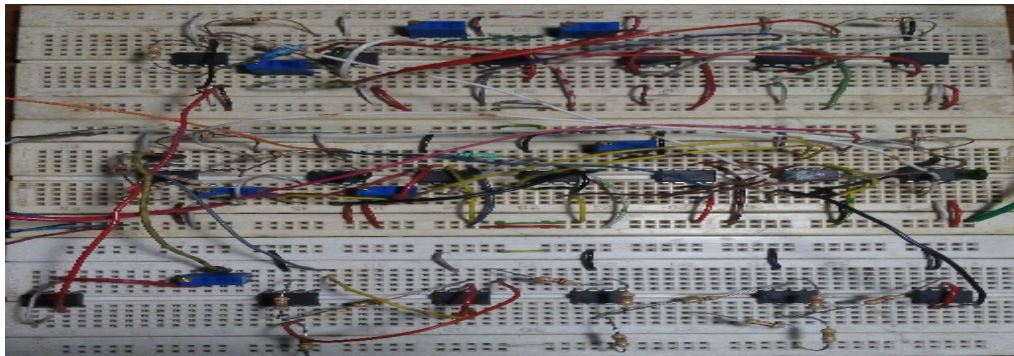

Fig. 7: Complete synchronization of coupled Non-Identical and Periodically Forced ϕ^6 -Duffing and ϕ^6 -Van der Pol circuits for $R_C = 1m\Omega$.



(a)



(b)

Fig. 8: Non-Identical and Periodically Forced ϕ^6 – Duffing and ϕ^6 – Van der Pol Circuit for masking information in secure communication: (a) Electronic design via multism (b) Hardware implementation.

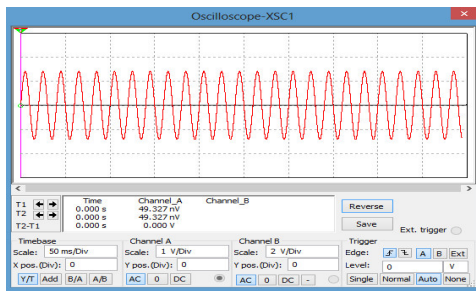

a(i)

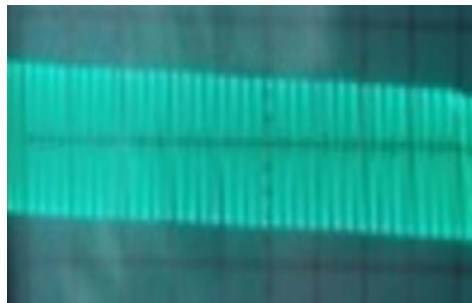

b (i)

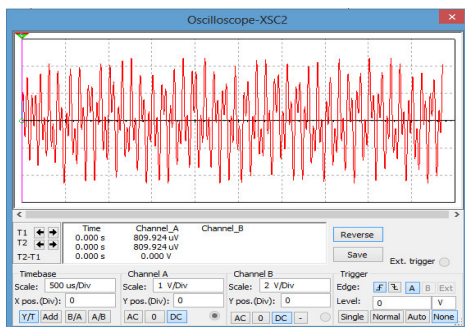

a(ii)



b (ii)

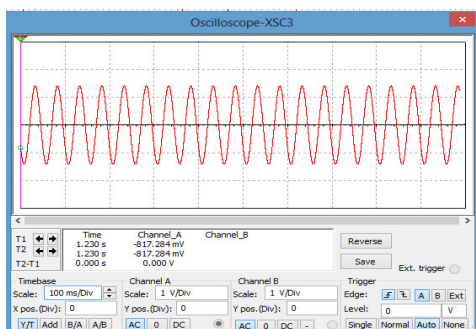

a(iii)



b (iii)

Fig. 9: A display of (i) sinusoidal information signal of amplitude $1V$ and frequency $20kHz$, (ii) chaotic masking transmitted signal, and (iii) retrieved information signal: (a) multism results and (b) hardware implementation results.