

Android Based Smart Home System

Adamu S. Kadalla, Ahmed I. Tijjani and Matthew K. Luka
 Department of Electrical and Electronics Engineering
 Modibbo Adama University of Technology, Yola, Nigeria

Abstract—Conventional electrical installations used in various building today poses great difficulty for physically challenged and elderly persons to operate them. Sometimes it is also inconvenient for normal person to use productively. Because of the increasing number of both the elderly and the disabled persons, an implementation of a smart home system is proposed in this paper. In addition to the convenience, the system also provides a platform for *inclusion* of the elderly and physically challenged individuals in both homes and offices, thereby enabling them to contribute meaningful to the development of the economy. The system gives home users wireless control over the house hold lighting systems, ventilation systems and the home main gate using an application running on an android smart phone. It also provides the user with an up to date temperature reading of the surrounding and the energy consumed by the device in the house. A centralized controller was developed around PIC 18F4550 microcontroller to handle the data acquisition and processing for the system. The overall system performance was demonstrated in controlling lamps, fans and gate of a prototyped one bedroom flat and confirmed the success of the design.

Keywords —Android, Wi-Fi, Inclusive development, Smart Home, Energy Measurement, Microcontroller

I. INTRODUCTION

There is an increasing acceleration toward the Internet of Things (IoT) trend, where everything is becoming smarter by using information and communication technology (ICT). An ordinary card becomes smart card when a chip is embedded in it. A card reader also becomes smart card reader just because it reads a smart card. Smartphone evolved from mobile phones which in turn derived from a fixed line telephone technology. This technological trend have the effect of making the home smarter. Modern home are gradually shifting from the use of distributed switches to a centralized switching system that is based on wireless communications technology. This trend will significantly reduce the inconveniences associated with distributed switches located in different areas of the home. This is especially beneficial for persons with special needs such as the elderly or physically challenge persons. Invariably, smart home technology provides a simple solution for improving the home and enhancing convenience and productivity. Smart homes have been defined as the incorporation of technology and services via home networking for improving quality of life[1]. Smart homes are realized by the deploying a network of sensors,

actuators, biomedical monitors and other monitoring systems coupled with special wireless and wired system. These devices and systems gives residents the ability to program, manage, and operate various home systems such lighting systems, ventilation systems, electrical appliances and other household installations. The monitoring devices and systems are usually small and can be wearable or installed anywhere around the home.

Smart home technology is not only envisioned for luxury and *technological sophistication*, rather it is primarily a system that provides *inclusiveness* for persons with special needs like the elderly and the physically challenged individuals. According to the World Health Organization (WHO), around 785 million persons aged 15 years and older live with disability[2]. A substantial number of these individuals; about 110 million (14%) have significant difficulties in effectively performing their daily activities. A similar report by the Population Division of United Nations indicates that approximately 10% of the World's population is older than 60 years and it is empirically predicated that this figure will reach upto 21% by 2050[3]. This pervasive and unprecedented ageing trend has an enduring and profound implications for different aspects of human life. Smart technologies are promising platforms for improving life and productivity, thereby mitigating the challenges of aging and disability. The application of the smart home system is open ended and only limited by human imagination [4]. Nevertheless, the major application areas include the elderly home care, improving energy efficiency and demand-side management, enhancing comfort and safety of homes and so on. Smart homes obviously have the ability to make life easier and more convenient as well as improve productivity. It is also a means of ensuring energy efficiency and savings. For example sensor networks based on Z-Wave and ZigBee can be used to place some devices on *sleepmode* which reduces their functionality and consequently their power consumption until wake up commands are given. Smart home adjust the home to suit our needs in response to a more efficient lifestyles. For example, lights can be automatically turned off when a person leaves the room, and rooms can be cooled or heated depending on who is there at any given moment. This adjustment of the home translates into lower electric bills in a pre-defined manner. The conveniences of smart home technology promises tremendous benefits for an elderly person living alone, which oftentimes is the case. Because of the versatility of its areas of application and

increase in the usage of the smartphone, smart home systems has drawn the attention of many researchers and companies. For instance,[5], [6]presented Bluetooth based home automation systems using Android Smartphones connected directly to a bluetooth sub-controller. However, the bluetooth technology does not provide a means of internetcontrollability. Home devices were physically connected to a Bluetooth sub-controller which is then accessed and controlled by the Smartphone using built-in Bluetooth connectivity. Bluetooth is also limited to short distance and the system can only be paired with one device at a time. Also in[7], a Wi-Fi based approach was used. It consists of hardware interface modules, a micro Web-server based on Arduino Ethernet and an Android compatible Smartphone application. Our contribution is the design of an Android based smart home system from scratch that will be more flexible and cost effective. A Wi-Fi access point infrastructure is used to integrate internet controllability of the home.

II. SYSTEM DESCRIPTION

The overall system consist of a sensors unit, actuators unit and main controller unit. Fig. 1. Shows the functional block diagram of the system. User interface is provided by an application installed on an android smartphone through which commands can be issued by the end user. These commands are converted into "GET /" request by the android application and send through Wi-Fi connection to the smart home controller with the aid of Wi-Fi Module. The controller process the received command and act upon the request. This request can be switching ON/OFF load, reading the ambient temperature, opening/closing the house gate, or reading the energy consumed by the home. After processing the request, a feedback in form of JavaScript Object Notation (JSON) is generated by the controller and transmitted back to the android application via the same link. Upon receiving the feedback, the application update or populate the user interface.

III. HARDWARE ASPECT

The controller unit consist of PIC18F4550 microcontroller and a Wi-Fi Module. The module is made up from MCW1001 TCP Stack and MRF24WB0BA wireless chip. This section is subdivided into home automation and energy metering system. Communication between the smart home system and the android smart phone is achieved via an Access Point or a router. Home automation involves the incorporation of intelligence into various electrical and electronic devices to better fulfill several functions in the house for the well-being of the householders. Example of systems that can be automated are ventilation systems, cooking machines, air conditioners and heaters, refrigerators, thermometers, lighting system, security cameras,

power outlets, energy meters, smoke and sound detectors, televisions, game consoles and other entertainment devices, doors and windows controllers, etc. The intelligent functions can be realized by using sensors and actuators.

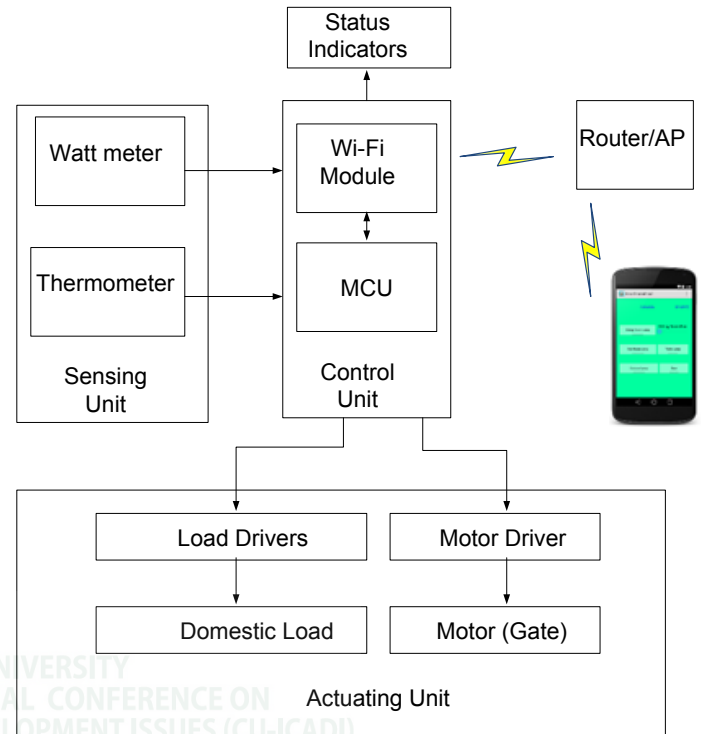

Fig. 1 System functional Block Diagram

A. Lighting and ventilation system

In this paper four lamps and one fan are used as lighting and ventilation respectively. They are statically switched using TRIACs. The speed of the fan is controlled using Pulse Width Modulation (PWM). Fig. 2 shows the circuit diagram of the load drivers.

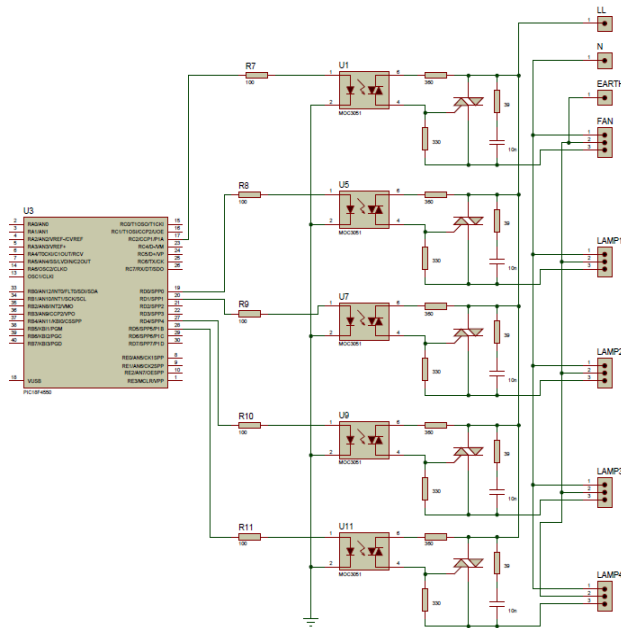

Fig. 2. Domestic Load Drivers

B. Temperature sensing unit

The surrounding ambient temperature was measured using a digital thermometer (DS18B20) and the readings are transmitted to the microcontroller via one wire communication (1²C) technology. The microcontroller compute the temperature and include it in the JSON file any time a GET request is made. The circuit of Fig. 3 shows how the sensor was interfaced with microcontroller.

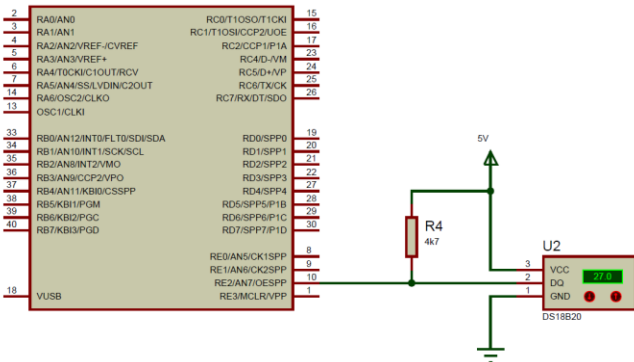

Fig. 3 Temperature sensor.

C. Gate controller

The house main gate is operated using H-Bridge driver which drive the motor either open or close based on the user input. Two limit switches were used to interrupt the supply when the gate is fully opened or closed. This is illustrated in Figure 4.0.

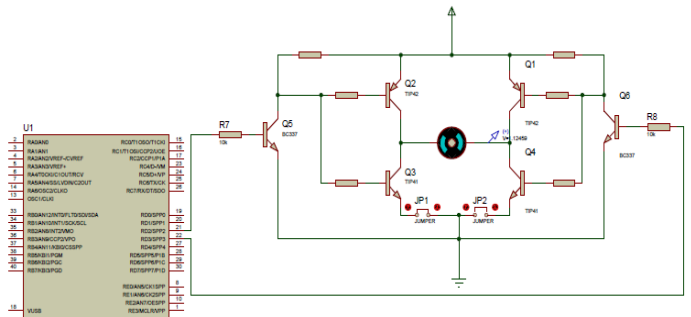

Fig. 4 H-Bridge Motor Driver

D. Energy Metering System

This portion of the smart home measures the energy consumed by the home. It consist of a voltage and current sensing component. Hall Effect sensor and opto-couplers were used to measure the current consumed by the load and voltage level respectively. This analog parameters are converted into digital using the in-built Analog to Digital Converter (ADC) of the microcontroller. The ADCs are sampled every one second. The calibrated digital values are multiplied to give the power consumed. Energy consumed is obtain by multiplying thepower by number of seconds and stored in the EEPROM of the microcontroller the equation 1 below shows how the energy usage isupdated.

$$E_{new_value} = E_{old_value} + ivt \tag{1}$$

Where E_{new_value} represent the value to be store in the EEPROM, E_{old_value} is the previously stored value from EEPROM and i , v and t are the instantaneous current, voltage and number of seconds respectively. Timing was achieved using internal timer module of the microcontroller. Refer to Fig. 5 for the circuit diagram

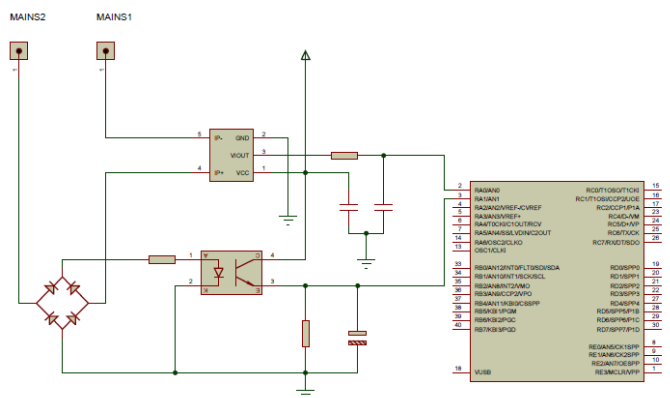

Fig. 5 Watt Meter

IV. MICROCONTROLLER PROGRAM AND SMART HOME
ADBROID APP

The controller unit consist of microcontroller which required a program to function. The program can be written in various programming languages like Assembly, C, BASIC and others. The flowchart shown in Fig.8 represents the program flow of the smart home. The microcontroller initialize the Wi-Fi module to scan for a specified access point or router and connect to it after authentication is made. It also store the state of the loads and sensors in EEPROM after executing a request.

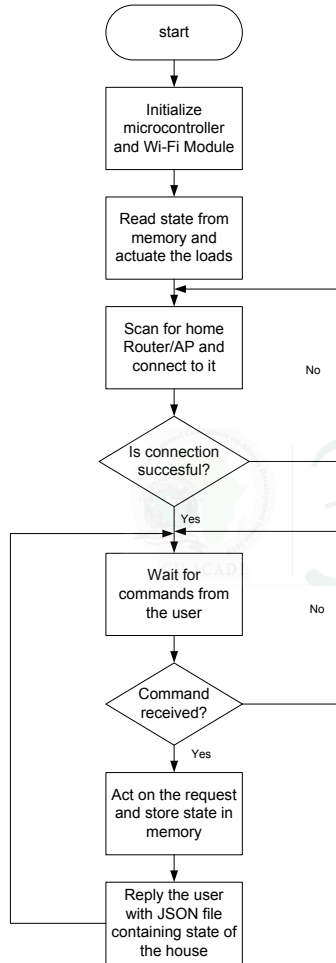

Fig. 6 Program Flow Chart

The stored state will always be loaded whenever the system is powered on. Command from the android application is made up of GET request as explained below.

$$GET /x = y$$

Where x represents a load while y is the state of the load. For example, a, b, c, d, e, and f represent fan, Lamp1, lamp2, lamp3, lamp4 and gate respectively. The State of each load is represented by either 0 or 1 for the lamps and 0, 1, 2, 3, for the

fan. The following is the content of the JSON file replied by the controller to the android application.

```

    {
      "SmartHome": [
        { "name": "fan", "value": "0" },
        { "name": "lamp1", "value": "1" },
        { "name": "lamp2", "value": "0" },
        { "name": "lamp3", "value": "0" },
        { "name": "lamp4", "value": "0" },
        { "name": "energy", "value": "0032" },
        { "name": "temp", "value": "00546" },
        { "name": "gate", "value": "0" }
      ]
    }
  
```

Android is an open source software stack for mobile devices that includes an operating system, middleware, and key applications. The android platform consist of several wireless connectivity options including Wi-Fi, Bluetooth, and wireless data over a cellular connection. It also provide a wide range of useful tools and libraries that can be used to build rich applications. The Android software development process consist of a number of steps for creating applications for the Android operating system. Applications are usually developed in Java programming language using the Android software development kit (SDK), but other development environments are also available. Android applications are built as a combination of different components that can be invoked individually. For instance, the main activity of Fig. 7 provides a single screen for user interface to other components. Services for various components independently performs various functions in the background. Fig. 7 shows the use cases diagram of the smart home application for this work.

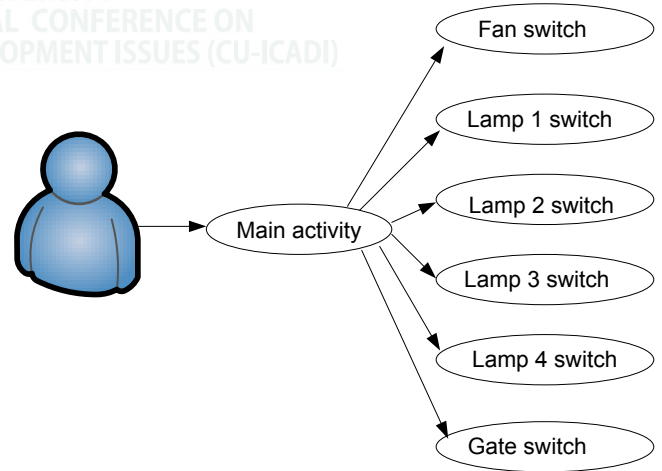

Fig. 7 Use Case Diagram

The app was developed using Android Studio. It contains a Seek Bar that is used to control the fan, Toggle Buttons for Lamps and gate control and two labels for displaying the temperature and energy consumed by the house. Fig. 8 shows the snap shot of the application user interface.

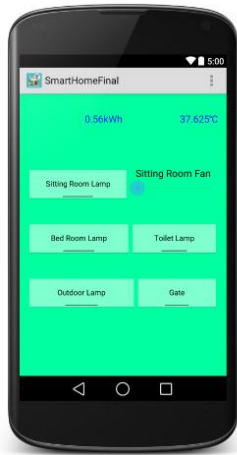

Fig. 8 Smart Home app

24, pp. 83–86.

- [7] R. Piyare, "Internet of Things: Ubiquitous Home Control and Monitoring System using Android based Smart Phone," *Int. J. Internet Things*, vol. 2, no. 1, pp. 5–11, 2013.

V. CONCLUSION

Generally, mobile applications can be used to improve productivity. For physically challenged and elderly individuals in particular, it is a veritable platform for significant contribution to the work force of the economy. This will help leverage the experience of professionals who are constrained by age or disability by incorporating convenience that enhance productivity into their working environment and homes. In this work an android based platform for enhanced convenience and productivity was developed. Additionally, the system gives the ambient temperature of a desired location in the home, to serve as an environmental safety indicator. The system also updates the user on the energy consumption of the home. This will facilitate demand-side management which is beneficial for both the user and the electricity utility company.

REFERENCES

- [1] "Smart Homes." [Online]. Available: http://www.tiresias.org/research/guidelines/smart_home.htm. [Accessed: 15-Mar-2016].
- [2] World Health Organization, "World Report on Disability," 2011. [Online]. Available: http://whqlibdoc.who.int/hq/2011/WHO_NMH_VIP_11.01_eng.pdf. [Accessed: 20-Mar-2016].
- [3] World Health Organization, "Magnitude and Speed of Population Ageing." [Online]. Available: <http://www.un.org/esa/population/publications/worldageing19502050/>. [Accessed: 15-Feb-2016].
- [4] R. Piyare and T. M., "Bluetooth Home Automation Using Cell Phone," in *Consumer Electronics, IEEE 15th International Symposium on*, 2011, pp. 192 – 195.
- [5] M. Yan and H. Shi, "Smart Living Using Bluetooth-Based Android Smart Phone," *Int. J. Wirel. Mob. Networks*, vol. 5, no. 1, pp. 65–72, 2013.
- [6] R. Piyare and S. R. Lee, "Smart Home-Control and Monitoring System Using Smart Phone, Department of Information Electronics Engineering, Mokpo National University Mokpo 534-729, South Korea," in *1st International Conference on Convergence and its Applications*, 2013, vol.