

Optimizing Hydroelectric Power Generation: The Case of Shiroro Dam

Olawale O. E. Ajibola, Olamide S. Ajala, James O. Akanmu and Oluwaseyi J. Balogun, *Member, IAENG*

Abstract—Hydroelectric power, one of the most important sources of mass generation of electric power, is a renewable source of energy. The amount of electricity that can be produced by a hydro-electricity generating system depends on systemic variables viz; plant efficiency, volumetric water flow through the turbine and the head of the water from the water surface to the turbine. The availability of the Water in the reservoir is a function of some hydrological variables principal among which are rainfall, reservoir inflows and evaporation. Understanding the dynamics of these variables, and the correlation between them are core to proper planning and management of a hydroelectric power station. In this Study, simple mathematical methods that include linear programming and statistical analysis based on simulation techniques were used to evaluate vital parameters based on the hydrologic data obtained from the Hydrologic Units of the Shiroro Power Stations in Nigeria. The overall aim of the study is to idealize power generation at Shiroro dam in and out of rain season so as to ensure optimum generation of electricity all year round in order to achieve energy sufficiency in Nigeria.

Index Terms—hydroelectric power, pumped storage, hydrological variables, simulation techniques.

I. INTRODUCTION

IN Nigeria almost every human endeavour has been paralyzed. A major factor that has reduced the standard of living of an average Nigerian to near zero is the epileptic supply of electric power. Government policies formulated at different times to curb the unfortunate trend were of no effect. To this end, 90% of factories in the manufacturing sector are moribund. The sporadic supply of power in Nigeria affects every sphere of human endeavour; from all forms of domestic discomfort to national embarrassment. For instance there was a three hour power outage at the Muritala Mohammed International Airport in Ikeja, Lagos on Sunday the 9th day of May, 2010 and the ugly incidence was repeated on Tuesday the 11th of May of the same year. Power supply situation in Nigeria has no doubt affected the economy of the nation negatively in no small measure.

Basically, the power generated at an hydroelectric power plant results from the kinetic energy that produce the torque obtained from the mass of water that falls through the height, h ; the differential of head of water from the inlet point H_1 , and the head of water above the turbine H_2 . Hence

$h = H_1 - H_2$. The process of conversion involves a hydraulic turbine which converts the kinetic energy of the flowing water into mechanical work that produce a torque. A dynamo then converts the torque thus produced into electricity. The operation of a generator is based on Faraday's principle of electromagnetism. Faraday propounded that when a magnet is moved past a conductor, it causes electricity to flow in the conductor. In a large generator, electromagnets are made by circulating direct current through loops of wire wound around stacks of magnetic steel laminations. These are called field poles, and are mounted on the perimeter of the rotor. The rotor is attached to the turbine shaft, which rotates at a fixed speed. When the rotor turns, it causes the field poles (the electromagnets) to move past the conductors mounted in the stator that causes electricity to flow and develop potential difference across the generator output terminals [1]. Hydro electric power generation thus produced is computed from the mass of water that flows through the Turbine based on the release from the reservoir and constrained by the Turbines flow capacity [2]. The volume of water that passes through the Turbines is bounded by maximum and minimum Turbine flow. If there is too much water, excess water is released through spillways which do not contribute to the generation of electricity. If however the release is less than the minimum Turbine flow then no electricity is generated. Therefore the amount of electricity that can be generated at hydroelectric plant is dependent upon two factors, [3]. These factors are:

- (1) The vertical distance through which the water falls usually refers to as the Head and
- (2) The rate of flow of water (m^3s^{-1}).

Thus the quantity of electricity produced is proportional to the product of the head and the rate of the flow. Accurate quantification of the reservoir content and adequate knowledge of reservoir operating policies is paramount to ensure optimal storage of water in the reservoir when managing production of hydroelectric energy. Climatic conditions affect both the availability and reliability of the water stored in reservoirs. To this end, optimum management of such reservoirs is very important under different climatic uncertainties [4, 5].

II. THRORETICAL CONSIDERATIONS

This section contains an elucidatory consideration of the theories and guiding policies upon which the systematic build-up of the models and solution contained therein are based. System Dynamics (SD) is a method for understanding the dynamic behaviour of complex systems [6]. The SD procedure includes: defining and identifying a problem, analyzing the problem, identifying possible

Manuscript received March 6, 2017; revised March 14, 2017.
Optimizing Hydroelectric Power Generation: The Case of Shiroro Dam.

Olawale Olaniyi Emmanuel Ajibola is with the University of Lagos, Akoka, Yaba, Lagos 23401 Nigeria (phone: +234-802-302-5053; e-mail: waleisiro@yahoo.com).

Olamide Sherifah Ajala is with Centre for Applied Dynamics, School of Engineering, University of Aberdeen. (e-mail: tommie_mide@yahoo.com).

James O. Akanmu is with the University of Lagos, Akoka, Yaba, Lagos 23401 Nigeria (e-mail:jakanmu@unilag.edu.ng).

Oluwaseyi Jessy Balogun is with the College of Medicine of the University of Lagos, Akoka, Yaba, Lagos 23401 Nigeria (e-mail: seyi8030@yahoo.com).

solution, developing an algorithm, selecting the best solution, evaluating the solution and implementing this solution.

Some of the characteristics of SD methodology which makes it suitable for this work include:

- i. Understanding the problem situation: The purpose is to clearly identify the problem and its causative factors as well as the relationships between them;
- ii. Explicit conceptual model and simulation model building: a sign causal diagram is drawn in order to develop the understanding of influence of the variables on each other. Explicit concepts of SD such as flows, levels and auxiliary are used in simulation model building process;
- iii. Simulation and gathering the results: after building the simulation model, it is then possible to analyze different scenarios for different policies

An over view of a hydro-electric power plant indicates that:

- a) Hydro-electricity generators converts the kinetic energy of the falling water into electrical energy by using uninterrupted flow of water in motion to turn a Turbine connected to an electric generator.
- b) The amount of electricity that can be produced by hydro-electricity generating system depends on the plant efficiency, volumetric water flow through the turbine, and the head of the water from the water surface to the turbine

Therefore the most important hydrological data required for hydropower studies are the long term reservoir inflows records that represent the flow variable for power production. Others includes rating curves, reservoir storage elevation, evaporation loss and other types of losses, sedimentation, water discharge data and downstream requirement [7]. The principle of hydroelectric power generation is based on the law of conservation of energy where kinetic energy that resulted from the movement of the mass of water from the river is translated to stored energy which in turns exacerbates the build-up of the kinetic energy that turns the turbine and ultimately produces electricity in Figure 1 [5].

The total power output P , that can be generated from water in hydroelectric power plant is directly proportional to the height h of water from the inflow to the turbine and the rate, r of flow of water. Thus:

$$P \propto rh \quad (1)$$

$$\therefore P = grh \quad (2)$$

where g is the acceleration due to gravity (usually, $g = 9.81 \text{ m}^2\text{s}^{-1}$).

If the head of water translates to release, then higher volume of water in the reservoir will translate to higher quantity of electricity produced by the hydroelectric power (HEP) plant [8, 9]. To maximize HEP therefore the head of water (HoW) in the reservoir must be adequately high such that the difference between the HoW and the turbine must be at premium so that the kinetic energy produced by the mass of water will be adequate to produce the require torque that will generate expected power output. The maximum height of water is fixed by natural factors like the height of river bed, the amount of water involved and other environmental factors. The location of the power generation unit can be adjusted based on the maximum total power output that would be generated. Usually the power generation unit is located at levels lower than ground level

so as to get the maximum head of water. The total flow rate of water can be adjusted through the penstock based on the design requirements [10].

A. The Pumped Storage Phenomenon

Pumped-Storage is a well-known technology evolving from the Hydro-Electric family of power plants. About 300 projects are in operation all over the world, with a total installed capacity of 83,000 MW. Currently, several tens of similar projects are under construction. Pumped-Storage stores excess electricity generated during times of low demand (such as night periods) and plunges it back to the system by pumping back the used volume to attain fresh water head which is in turn used to turn the turbine when demand is high [11]. Its immediate response prowess lead to the performance of expected functions such as: load regulation, spinning reserve, frequency and voltage regulation, load and dispatch management, all of which are referred to as dynamic benefits. It is friendly to the environment, with no emissions of pollutant [11, 12]. The unique characteristics of Pumped-Storage made it viable in most developed and developing countries ([13].

Pumped storage hydroelectricity option is a method of producing electricity stored for usage when demand is at its peak [14]. At times of low demand for electricity, excess electrical energy generated is used to pump water into an elevated reservoir for usage during peak period when the stored water is released back into the lower reservoir via a turbine, thereby generating more hydroelectricity. About 70% of the additional electrical energy is thus generated over and above the capacity of the original energy produced by the same volume of water where conventional hydroelectric system is used as currently done in Shiroro dam [15]. To cut cost, some facilities use abandoned mines site as the lower reservoir. Many other facilities use the natural height difference between two natural bodies of water such as expanded lake or artificial reservoirs [16].

Pumped storage hydro-electricity works on a very simple principle. Two reservoirs at different altitudes are required (one above the turbine, the other below it). When the water is released, from the upper reservoir, energy is created by the down flow which is directed through high-pressure shafts, linked to turbines. In turn, the turbines power the generators to create electricity. To achieve this feat, water is pumped back to the upper reservoir by linking a pump shaft to the turbine shaft using a motor to drive the pump. The pump motors are powered from the energy generated by the hydroelectric system. However, the gains of the process can be obtained from the efficacy and the efficiency derivable from the recurrent process. A dynamic response involving generating units of the system can achieve maximum output, usually, within 16 seconds of their operation. Pump storage generation offers a critical back-up facility during periods of excessive demand on the national grid system.

In recent time, research efforts have been directed towards the development of reverse-engineered conventional pumps that can be used as hydraulic turbines. A centrifugal pump operates like a water turbine when it is run in reverse order. Because the pumps are mass-produced, they are more readily available and less expensive than turbines. It is estimated that the cost of a pump-as-turbine

(PAT) is at least 50 percent less or even lower than that of a comparable turbine. However, for adequate performance, a micro-hydropower site must have a fairly constant head and flow because PATs have very poor partial-flow efficiency. It is possible to obtain full efficiency from PATs by installing multiple units, where they can be turned on or off depending on the availability of water in the stream. PATs are most efficient in the range of 13 to 75 m (40 to 250 ft.) of gross head. The higher the head, the less expensive the cost per kilowatt; this is generally the case with all turbines [17].

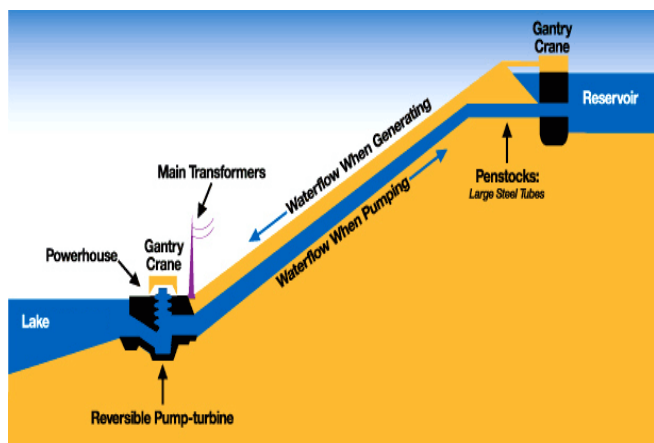

Fig 1 : Schematic of pumped storage power plant

Source: Ulowa Wiki

TABLE I
SUMMARY OF EFFICIENCY OF VARIOUS PUMPS

Impulse turbines	
Prime Mover	Efficiency Range
Pelton	80-90%
Turgo	80-95%
Cross-flow	65-85%
Reaction turbines	
Prime Mover	Efficiency Range
Francis	80-90%
Pump-as-turbine	60-90%
Propeller	80-95%
Kaplan	80-90%
Water wheels	
Prime Mover	Efficiency Range
Undershot	25-45%
Breastshot	35-65%
Overshot	60-75%

The difference between the level of the upper and lower reservoir is the head, for very high head it is necessary to use multistage pumps. However, for large installations with one stage pumps, a head in the range of between 300 and 600m is required. For instance, 4 million cubic meter reservoir capacity is required to produce 1000 MW in four hours at 400 m head. Seasonal storage reservoirs may require a capacity larger than one billion cubic meters to sustain pumped storage that will last the season. A pumped storage station costs in excess of US\$2500/kW and the overall losses are about 25%. Most pumped storage stations store sufficient water for 6-10 hours of operation [18]. The efficiency of the system depends on the length and design of the hydraulic subsystems and machinery, especially the reversible units of the pump turbines or separate pumps and turbines. Usual efficiency ranges between 70 – 80% for the pumping/production. Main Functions of pumped storage hydroelectric system are:

- i. Only solution for efficient and cost effective means of storing large amounts of energy
- ii. Acts as a quick response for peak load energy supply
- iii. Provide ancillary services (network frequency & voltage regulation, reserve capacity, black start capability, reactive power production)

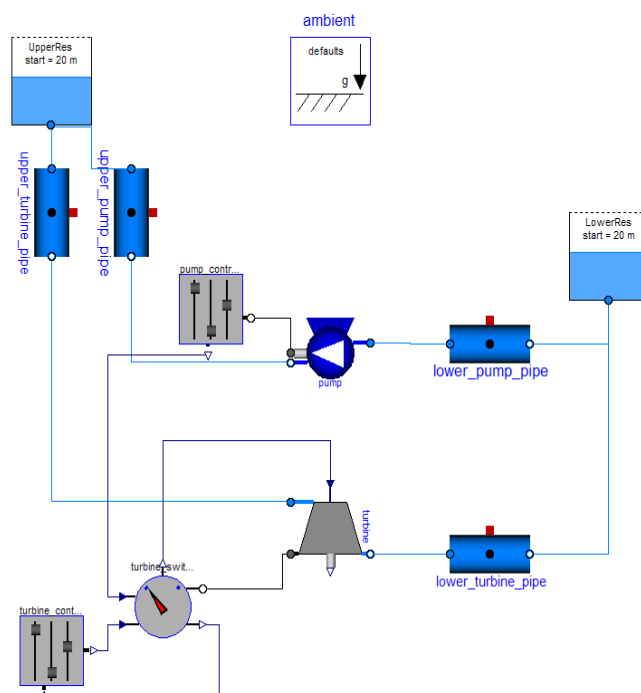

Fig 2: Overall pumped-storage system model

And the advantages include:

- i. Increase in profitability for plant owners in volatile electricity spot markets
- ii. Allowance of optimization of global operations of power plant fleets and electrical network infrastructures
- iii. Has higher global cycle efficiency compared to other large storage solutions (approximately 80%)
- iv. Has a positive environmental impact by enabling increased use of renewable energy sources [18].

The statistics of pumped storage plants worldwide is as summarized in Table 2 below:

Table 2
Global pumped-storage plants statistics

Country	Description of Facility	Capacity Installed MW
China	Guangzhou pumped storage power station, Hong-Kong	2,400
	Tienhuangping Pumped Storage Project	1,800
United Kingdom	Dinorwig, Wales	1320
	Ffestiniog Pumped Storage Plant, Wales	360
United States	Ludington Pumped Water Plant	1872
	Mt. Hope Pumped Water Plant,	2,000
	Mount Elbert	200
	Summit Pumped Water Plant,	1500
Others	Rance River, St Malo France hybrid pumped water-tidal plant	240
	Drakensberg Pumped Storage Scheme, South Africa.	1,000 MW

The basic equation that relates release with energy produced in an hydroelectric system is given by:

$$kWH_t = 2725 R_t H_t n \quad (3)$$

where R_t is the release into the penstock in Mm^3 , H_t is head in meters and n is efficiency.

A biometric analysis of the data supplied by Shiroro dam management for average turbine flow and inflow revealed incoherent correlation which failed to make a categorical statement about the truth of its empiricism and therefore cannot be applied in any serious scientific research work upon which the fate of such an important magnitude as the power generation project could be based. We have randomly selected July 23 of each year under consideration. Table 3 revealed a major anomaly in the structure of the data selected through stochastic process from the pool of the aforementioned data. A close study shows that in 2003 for instance release is greater than inflow. The chart in Figure 3 presents a more expository revelation of our claim.

TABLE 3
RECORDS OF INFLOW, RELEASE AND POWER
GENERATED IN SHIRORO DAM (1990 AND 2004)

YEAR	INFLOW	PGN(MW)X10 ³	RELEASE
2004	72929.1	242.5629	115879.2
2003	103025.7	253.8834	116120.9
2002	82580.84	218.8941	101550.9
2001	84914.1	267.5201	122366.5
2000	77394.03	257.1351	102406.1
1999	93149.9	209.7861	105938.4
1998	81361.84	214.1446	107417.4
1997	83817.42	223.0044	103589.6
1996	77454	201.9469	95395.35
1995	55352.16	194.4828	90808.48
1994	81935.19	204.794	96428.16
1993	73861.74	211.9957	97810.77
1992	80755.34	230.0002	108718.6
1991	73541.35	199.7155	90598.74
1990	73343.42	215.26887	97404.26

Based on these observations it is obvious that the data provided in Shiroro dam cannot be relied upon, hence the need for simulation of data. Equations (12) to (20) were solved through the software named TORA, eight iterations were performed. The storage k of the reservoir is been varied and the result is as tabulated in Table 3 in the appendix.

III. METHODOLOGY

Reservoir operation is an important element in water resources planning and management. It consists of several control variables that defines the operation strategies for guiding a sequence of releases to meet specific demands of the stakeholders with different objectives, such as flood control, hydropower generation and allocation of water to different users. A major difficulty in the operation of reservoirs is the fluctuation in storage. Therefore, it is necessary to optimize reservoir operation in determining adequate water storage for generation of hydropower, [19, 20, 21, 22].

Of concern in this work is the uninterruptable supply of water resources into the reservoir to ensure adequate supply

of water for the purpose of generating electricity from a hydroelectric system all year round, especially during drought and dry season. To this end, pumped storage may be introduced in the hydropower plant to facilitate an efficient recycling of the available water resources at these periods of the year. According to the U.S department of the Interior Bureau of Reclamation Power Resources Office, July 2005, demand for electrical power supply varies greatly during the day and night. These demands vary considerably from season to season. In other to maximize storage so as to ensure constant electrical power supply, it is necessary to find a way of recycling the water used to turn the turbine [23]. Hence a pumped storage, the basic principle of which entails that the release from the reservoir is pumped to a storage tank where it can be used to return the turbine during the period of drought, thus ensuring constant supply of electricity the year round.

Optimization models are based on clearly defined goals (objective functions), criteria for evaluation of control decisions, and constraints as limitations during optimization [24, 25, 26, 5]. In our own case, it is enough to maximize storage so that the Shiroro Hydroelectric power plant will have adequate water supply the year round. The typical constraints in a reservoir optimization model, including conservation of mass and other hydrological and hydraulic constraints, minimum and maximum storage and release, hydropower and water requirements as well as hydropower generation limitations, are presented as follows:

i. Hydraulic constraints are defined by the reservoir continuity equation.

$$S(t+1) = S(t) + I(t) - R(t) - E(t) \quad \forall t = 1, 2, \dots, T \quad (4)$$

Where $S(t+1)$ is storage at time step $t+1$; $S(t)$ is storage at time step t ; $I(t)$ is the reservoir net inflow at time step t (including reservoir inflow, precipitation and evaporation); $R(t)$ is the reservoir outflow at time step t , $E(t)$ is the evaporation loss at time step t corresponding to the water spread area at the average storage $[S(t) + S(t+1)]/2$. T is the total number of time steps in the period under consideration.

ii. Constraints on discharge defined by maximum and minimum permissible reservoir releases:

$$R_{\min} \leq R(t) \leq R_{\max} \quad \forall t = 1, 2, \dots, n \quad (5)$$

iii. Constraints on storages defined by maximum and minimum permissible reservoir storages:

$$S_{\min} \leq S(t) \leq S_{\max} \quad \forall t = 1, 2, \dots, n \quad (6)$$

iv. Constraints on elevations defined by maximum and minimum permissible level at specified sites:

$$h_{\min} \leq h(t) \leq h_{\max} \quad \forall t = 1, 2, \dots, n \quad (7)$$

v. Constraints on hydropower generations defined by maximum capacity and minimum requirement of hydroelectricity:

$$H_{\min} \leq H(t) \leq H_{\max} \quad \forall t = 1, 2, \dots, n \quad (8)$$

$HP(t)$ is a nonlinear function of $S(t)$ and $R(t)$.

vi. Energy production, expressed as the energy production capacity (EPC):

$$EPC = C^* \leq REQ(t) * H(t) * H(t) * \eta \quad \forall t = 1, 2, \dots, n \quad (9)$$

where C is the conversion factor for potential to electrical energy, H is the average head over turbine and η is the energy plant efficiency.

- vii. The energy that can be produced is restricted by the plant capacity (PCAP) and number of hours available for energy production (NHP). Thus, the maximum peak energy produced (MPEP) is:

$$MPEP(t) = PCAP(t) * \eta * NHP(t) \quad \forall t = 1, 2, \dots, n \quad (10)$$

The energy produced at any time t is:

$$PKE(t) = \min(TEP(t), MPEP(t)) \quad \forall t = 1, 2, \dots, n \quad (11)$$

where PKE is the peak energy produced and TEP is the total energy that can be produced at a particular time. One of the problems associated with the operation of the reservoir is the operational and release policy adopted. At Shiroro reservoir, annual flooding of lower Niger plains occurs when the spillways are opened in September during high inflows. While during the period of low inflows (March to May), head of water in the reservoir is often below the desired level. Operation of reservoirs is based on experience of the water managers. A viable resolution of these anomalies may therewith be found with the proposed optimization technique which employs the recycling of released R_t as the inflow of the reservoir [11].

A. Optimizing the Reservoir's Operation

From literature, the energy production capacity (EPC) is more than often, a function of storage [27, 28]. However storage at time t is determined by the inflow of water and storage at time t is determined by the inflow of water and the storage at time $(t-1)$ when a discretized variable is used. It therefore follows that the EPC can be wholly determined by the storage of the reservoir. Hence, to maximize EPC output is tantamount to maximizing storage. The objective function for the reservoir optimization process is simplified thus:

$$\text{Maximize } \sum_{t=1}^T [S(t) + I(t)] \quad (12)$$

Subject to:

$$S(t+1) - S(t) - I(t) - R(t) - l(t) = 0 \quad (13)$$

$$R(t) - I(t) \leq 0 \quad (14)$$

$$S(t+1) \leq K \quad (15)$$

$$I(t) + 0.7R(t) \leq K \quad (16)$$

$$l(t) - 0.3R(t) \leq 0 \quad (17)$$

$$R(t) \leq K \quad (18)$$

$$I(t) \geq 0, R(t) \geq 0, S(t) \geq 0, l(t) \geq 0 \quad (19)$$

$$S_{\min} \leq S_{\max} \leq K \quad (20)$$

$$\forall t = 1, 2, \dots, n$$

where, S_{t+1} is the final storage at time t ; S_t is the storage at the beginning of the period t ; K is the storage capacity of the reservoir; R_t is the release at time t ; l_t is the total loss at time t while I_t is the inflow at time t .

Equation (13) is the reservoir continuity equation, while equation (14) is implemented to account for the recycling of the release used to turn the turbine. The flowchart for the methodology is as shown in Figure 2.

B. Reservoir's Inflow and Release Statistics

This section provides the summary of the statistics obtained from the various analyses made using the approach adopted in the preceding section. Table 4 is a collection of the statistical parameters used as decision variables for our analyses. The figure below shows the graph of inflow and release from the reservoir against years under consideration, from the graph, it can be perceived that from January to May of these years the release is comparatively greater than inflow while from June to August of the same period the inflow is appreciably greater than the release. This shows that an extra storage must be somewhere around the downstream to make-up for the shortfalls in the release from January to May to optimize the hydroelectric power generated for these months. To this end, a pumped storage becomes a viable solution to the irregularity observed in the data.

Despite many devoted effort to correctly forecast rainfall and run off, rainfall prediction still remain problematic. Rain is a form of precipitation. It is the water that falls from the cloud to the ground through hydrological cycle. The radius of a drop of rain is slightly greater than 250 μm . The pattern and invariably the amount of rainfall are among the most important factors that affect the output of hydroelectric power generating systems [29].

TABLE 4
RECORDS FROM PATTERN OF RAINFALL INTO SHIRORO
DAM BETWEEN 1990 AND 2008

YEAR	MEAN (mm)	MEDIAN	STDV	MAX
2008	88.2	28.9	115.5663	305.7
2007	119.916667	83.55	126.3198	332.3
2006	128.075	78	150.0853	425
2005	92.2083333	64.15	103.347	247.1
2004	85.025	44.45	96.8482	236.4
2003	110.058333	88.35	120.0423	351.5
2002	97.325	77	106.2391	286.6
2001	112.116667	78.85	128.6778	360
2000	102.625	95.2	114.6116	364.7
1999	113.1	73.5	131.1867	410.7
1998	104.591667	86	110.0194	280.8
1997	143.425	122	152.9154	473.2
1996	103.575	66.25	112.3733	307.2
1995	100.35	54.85	133.3404	443.8
1994	98.125	66.6	107.1328	264.7
1993	114.533333	50	138.5029	377.7
1992	120.2	107	125.7707	368.1
1991	113.191667	29.95	148.9809	450.3
1990	145.775	151.9	149.3903	416.1

Statistical observation obtained from pattern of these systems are precipitation dependent Rainfall are essential and are indeed fundamental to understanding the rainfall runoff process; therefore the accuracy of the rainfall data at some critical point is very important and significant to any specific use a set of data is applicable to. Subsequent paragraphs enumerate the import of main results of the evolving analysis of the record of rainfall at Shiroro hydropower stations during the period under consideration. The onus here is:

- a. To analyze a record of rainfall for the purpose of establishing trends or pattern of changes observed.
- b. To demonstrate the direct method of analyzing rainfall data that can be used for purpose of planning future power generation output.

In this paper, Microsoft excel software statistical package is used to analyze the Rainfall regime. The average annual rainfall in respect of Shiroro power project is 1325.213 mm with the highest rainfall record of 1749.3 mm in 1990 while the lowest record of 617.4mm was observed in 2008. The statistical measures of taken mean, maximum, minimum, the standard deviation and coefficient of variation of the annual rainfall for the station is shown in Table 4 while the summary of the statistics are presented in Table 5 .

TABLE 5
INFLOW/RELEASE FOR SHIRORO POWER PROJECT

SUMMARY STATISTIC					
	CORREL	COVAR	SLOPE	MEAN	STDV
RELEASE (1990-2007)				101671.3	13532.51
INFLOW (1990-2007)	0.6929	105796009	0.7851	78775.43	11945.15

IV. DISCUSSION OF RESULTS

Reservoir inflow observation is one of the most reliable methods of estimating the runoff yield. Understanding reservoir flow pattern is therefore fundamental to achieving outstanding success during the process of monitoring of water budget in a reservoir. We are required to know the lowest dependable flow on one hand and the highest flood level possible in the river on the other hand. The former is useful in the design of various components for proper optimization of water resources while the latter provides information of flooding which the structure will have to curtail [30, 31]. The flow rate of a river usually refers to the volume of water that passes through a section of the river in a unit time in m³/sec [32, 33]. The average annual turbine discharge by analysis at Shiroro is 9303.4m³/sec between 1990 and 2004, with Maximum turbine discharge of 12412m³/sec occurring in 2001. Figure 3 below shows the relationship between the inflow and the release from the reservoir for the years under consideration,

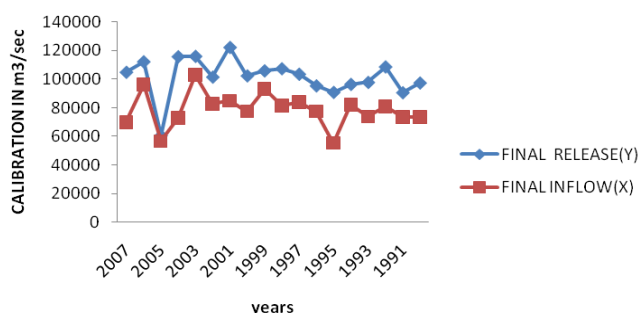

Fig 3: Inflow and the release from the reservoir for 1991-2007

The graph showing daily variation of reservoir inflow for the years under consideration is described by Figure 4. A verification of the relevance of inflow information to the development of a viable model for optimization process for hydropower system is presented in figure 5 while figure 6 is a direct implication of figure 5 since ideally release is proportional to inflow into the reservoir. The Biometric analysis of the inflow/release relationship in the case of

Shiroro hydropower project can be summarized by observing a linear relationship using regression analysis. This is presented in figure 7.

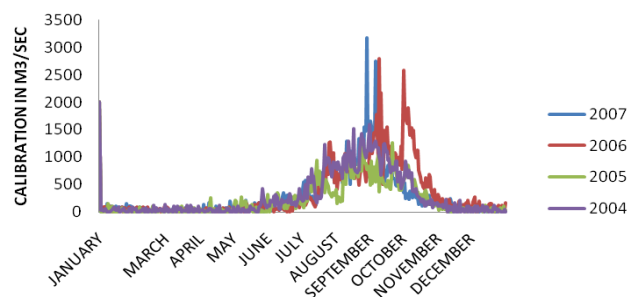

Fig 4: Daily inflow into the reservoir for the years under consideration

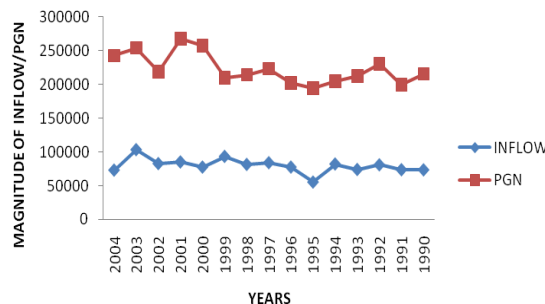

Fig 5: Relationship between inflow and power generated

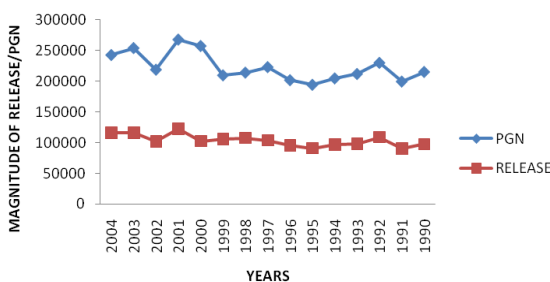

Fig 6: Relationship between release and power generated

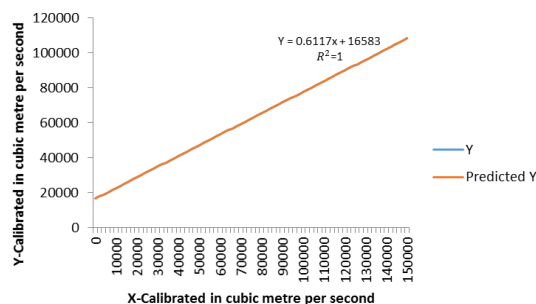

Fig 7: Regression line of inflow and release of the reservoir

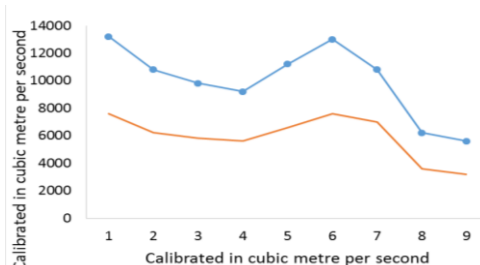

Fig 8: Optimized result z versus storage k in the reservoir

The regression analysis for the inflow and release of the reservoir was carried out using MS-Excel graphics. The release when there is no inflow as predicted by the regression line is 16583 while the rate of change of release with respect to inflow (slope) is 0.6117. Thus the equation as shown in the graph describes the variation of annual

reservoir inflow for various years. Figure 8 above depicts the relationship between the optimized result and the storage in the reservoir at anytime t and it can be inferred from the graph that there is a perfect correlation between z and k , that is for every increase in storage value there is a corresponding increase in the optimized result which shows that the linear program employed in the solution is consistent with the result of our analysis.

V. CONCLUSION

In the paper, we have proposed a new but simplified method for improving the efficiency and by implication, the production output of hydroelectric power generation at Shiroro dam especially during the period of drought. This work employs optimization models to explore viable engineering solution options thereby enriching the literature with the ultimate goal of arresting the tetra-headed monster that is responsible for the incessant power failure that has plagued the life of an average Nigerian for decades now. And it is our belief that our proposed model may reduce economic discomfort and curb colossal waste currently incurred both by the citizenry and government due to the inadequacies in the power sector of the economy. It may also lead to improved technological knowhow if properly harnessed in order that our collective efforts towards achieving Nigeria's developmental goals may come to fruition.

REFERENCES

- [1] H. Perlman, 2010. Hydroelectric power: how it works. <http://ga.water.usg.gov/edu/hyhowworks.html>.
- [2] H., Madsen, 2003. Parameter estimation in distributed hydrological catchment modelling using automatic calibration with multiple objectives. *Advances in Water Resources* 26(2): 205-216.
- [3] M. Karamouz 2003. Resources system analysis. Lewis Publisher. Washington, D.C. pp. 441-484.
- [4] R. E. Rosenthal, 1981. A Nonlinear Network Flow Algorithm for Maximization of Benefits in a hydroelectric Power system" *Operational Research*, Vol. 29, No. 4, pp 763-786.
- [5] C. Revelle, 1999. Optimizing reservoir resources: including a new model for reservoir reliability. John Wiley & Sons, Inc. pg 45-64
- [6] J. W. Forrester, 2009. Some basic concepts in system dynamics. Sloan School of Management, Massachusetts Institute of Technology. UK.
- [7] Mays, L. W. and Tung, Y. K., 2002, *Hydrosystems Engineering and Management*. Water Resources Publications.
- [8] US Power Resources Office 2005. Hydroelectric power: managing water in the west. Bureau of Reclamation, Power Resources Office, US Department of the Interior. USA.
- [9] T. Olaoye, T. Ajilore, K. Akinluwade, F. Omole and A. Adetunji, 2016. Energy Crisis in Nigeria: Need for Renewable Energy Mix. *American Journal of Electrical and Electronic Engineering*, 2016, Vol. 4, No. 1, 1-8.
- [10] S. Vedula and P. P. Mujumdar, 2005. Modelling techniques and analysis. Tata McGraw-Hill Publishing Company limited. New Delhi.
- [11] W. Yeh, 1985, Reservoir management and operations models: A state-of-the-art review. *Water Resources Research* 21(12): 1797-1818.
- [12] Y. M. Suleiman and I. P. Ifabiyi 2014. The role of rainfall variability in reservoir storage management at Shiroro hydropower dam, Nigeria. *An International Journal of Science and Technology*. Vol. 3(2), No 7, pp. 18-30
- [13] A.K. Jha, R. Bloch, and Lamond, 2012. Cities and flooding: a guide to integrated urban flood risk management for the 21st century. The World Bank, Washington.
- [14] M. V. F. Pereira and L. Pinto, 1985. "Stochastic Optimization of a Multireservoir Hydroelectric System - a Decomposition Approach." *Water Resources Research* 21(6): 779-792.
- [15] J. O. Akanmu, 2007; Model for the optimal operation of shiroro reservoir, PhD thesis. University of Lagos, Akoka. Nigeria.
- [16] X. Yang, E. Parent, M. Claude, and P.-A. Roche, 1995. Comparison of real-time reservoir-operation techniques. *Journal of Water Resources Planning and Management* 121(5): 345-351.
- [17] P. O. Yapo, H. V. Gupta, and S. Sorooshian, 1998. Multi-objective global optimization for hydrologic models. *Journal of Hydrology* 204: 83-97.
- [18] L.A. Fodstad, 2009. Pumped storage. [Risoe.dtu.dk/en/.../storage/lars_fodstad_tilladelsa.aspx](http://risoe.dtu.dk/en/.../storage/lars_fodstad_tilladelsa.aspx)
- [19] U. Karaagac, J. Mahseredjian, S. Denetiere, 2009. Modelling and Simulation of the Start-up of a Pumped Storage Power Plant Unit, International Conference on Power Systems Transients Kyoto, Japan.
- [20] A. B. Adegbehin, Y.O. Yusuf, E.O. Iguisi, and O. D. ZubairuJimoh, 2016. Reservoir inflow pattern and its effects on hydroelectric power generation at the Kainji Dam, Niger State, Nigeria. *WIT Transactions on Ecology and the Environment*, Vol 203; pp. 233 – 244.
- [21] A. B. Adegbehin, 2016. Effects of some weather parameters and reservoir inflow pattern on hydroelectric power generation in kainji dam niger state, Nigeria. M.Sc. Dissertation. Ahmadu Bello University, Zaria, Nigeria.
- [22] I. Duranyildiz, B. Onoz and M.Bayazit, 1999. A Chance-Constrained LP Model for Short term reservoir Operation Optimisation. *Turkish Journal of Engineering and Environmental Science* 23: 181-186.
- [23] J. Labadie, 2004. Optimal operation of multireservoir systems: state-of-the-art review. *Journal of Water Resources Planning and Management* © ASCE pp. 111
- [24] T. Akter and S. P. Simonovic, 2004. Modelling uncertainties in short-term reservoir operation using fuzzy sets and a genetic algorithm. *Hydrological Science Journal* 49(6):1081-1079.
- [25] L. Chen, 2003. Real time genetic algorithm optimization of long term reservoir operation. *Journal of the American Water Resources Association* 39(5): 1157-1165.
- [26] J. Kelman, J. Stedinger, L. A. Cooper, and E. Hsu, 1990. Sampling stochastic dynamic programming applied to reservoir operation. *Water Resources Research* 26(3): 447-454.
- [27] K. Chan-Ki, K. S. Vijay, J. Gil-Soo, L. Seong-Joo, L. Seok-Jin, 2009. HVDC Transmission: Power Conversion Applications in Power Systems. John Wiley and Sons (Asia) Pte Ltd. Singapore.
- [28] K. D. W. Nandalal. and J. J. Bogardi, 2007. Dynamic programming based on operation of reservoirs: applicability and limits. Cambridge University Press, UK.
- [29] R. Oliveira and D. P. Loucks, 1997, Operating rules for multireservoir systems. *Water Resources Research* 33(4): 839-852.
- [30] L. John, 2004. Optimal operation of multireservoir system: State-of-the-Art review. *Water Resources Planning and Management* 130(2): 93-111.
- [31] T. S. Abdulkadir, A. W. Salami, B. F. Sule, J. A. Adeyemo 2015. Neural Network Based Model for Forecasting Reservoir Storage for Hydropower Dam Operation. *International Journal of Engineering Research and General Science*. Volume 3, Issue 5, pp.639 – 647.
- [32] D. P. Loucks, J. R. Stedinger and U. Shamir, 1985. Modelling Water Resources Systems: issues and experience. *Civil Engineering System* Vol. 2, pp 1-9
- [33] W. L. Yeh, Becker, and W. Chu. 1979. Real-time hourly reservoir operation". *Journal of water Resources Planning and Management* (ASCE), Vol. 105(WR2), pp187-203.